

# APPENDIX 32

## QUANTITATIVE RISK ASSESSMENT OF THE PROPOSED FUEL STORAGE PROJECT AT THE CAPE WINELANDS AIRPORT IN DURBANVILLE, CAPE TOWN

PROJECT DONE ON BEHALF OF  
KANTEY & TEMPLER (PTY) LTD

# **QUANTITATIVE RISK ASSESSMENT OF THE PROPOSED FUEL STORAGE PROJECT AT THE CAPE WINELANDS AIRPORT IN DURBANVILLE, CAPE TOWN**

Author: M P Oberholzer  
Date of Issue: 14<sup>th</sup> of August 2024  
Report No.: 24K&T-09 Rev 1



Postnet Suite 010  
Private Bag X153  
Bryanston, 2021  
Cell: +27 (0) 82 457 3258  
E-mail: [mike@riscom.co.za](mailto:mike@riscom.co.za)

<b>DOCUMENT CHANGE HISTORY</b>			
<b>PAGE/LINE</b>	<b>CHANGE</b>	<b>DATE</b>	<b>REV</b>
Document	Initial release	24 <sup>th</sup> of June 2024	0
3-1	Updated Section 3.1	14 <sup>th</sup> of August 2024	1
5-7	Updated Figure 5-4	14 <sup>th</sup> of August 2024	1

## RISCOM (PTY) LTD

RISCOM (PTY) LTD is a consulting company that specialises in process safety. Further to this, RISCOM\* is an approved inspection authority (AIA) for conducting Major Hazard Installation (MHI) risk assessments in accordance with the OHS Act 85 of 1993 and its Major Hazard Installation regulations (July 2001). In order to maintain the status of approved inspection authority, RISCOM is accredited by the South African National Accreditation System (SANAS) in accordance with the IEC/ISO 17020:2012 standard.

The accreditation consists of a number of elements, including technical competence and third-party independence.

The independence of RISCOM is demonstrated by the following:

- RISCOM does not sell or repair equipment that can be used in the process industry;
- RISCOM does not have any shareholding in processing companies nor companies performing risk assessment functions;
- RISCOM does not design equipment or processes.

Mike Oberholzer is a professional engineer, holds a Bachelor of Science in Chemical Engineering and is an approved signatory for MHI risk assessments, thereby meeting the competency requirements of SANAS for assessment of the risks of hazardous components, including fires, explosions and toxic releases.

Opinions and interpretations expressed herein this report are outside the scope of SANAS accreditation.



M P Oberholzer Pr. Eng. BSc (Chem. Eng.) MIChemE MSAIChE

### **COPYRIGHT WARNING**

***All content included in this document is the property of RISCOM (PTY) LTD and is protected by South African and international copyright laws. The collection, arrangement and assembly of all content of this document is the exclusive property of RISCOM (PTY) LTD and protected by South African and international copyright laws.***

***Any unauthorised copying, reproduction, distribution, publication, display, performance, modification or exploitation of copyrighted material is prohibited by law.***

### **DISCLAIMER**

***This report was prepared by RISCOM (PTY) LTD. The material in it reflects the best judgement of RISCOM (PTY) LTD in light of the information available to it at the time of preparation. Any use that a third party makes of this report, or any reliance on or decisions to be based on it, are the responsibility of such third parties. RISCOM (PTY) LTD accepts no responsibility for damages, if any, suffered by any third party as a result of decisions made or actions based on this report.***

---

\* RISCOM® and the RISCOM logo are registered trademarks of RISCOM (PTY) LTD

# QUANTITATIVE RISK ASSESSMENT OF THE PROPOSED FUEL STORAGE PROJECT AT THE CAPE WINELANDS AIRPORT IN DURBANVILLE, CAPE TOWN

## EXECUTIVE SUMMARY

### 1 INTRODUCTION

The Cape Winelands Airport (hereinafter referred to as CWA) has purchased Fisantekraal Airport in Durbanville and is planning to upgrade the airport to accommodate commercial air traffic. As part of the upgrade, aircraft fuel tanks would need to be installed.

Since off-site incidents may result due to hazards of some of the fuels to be stored on, produced at or delivered to site, RISCOM (PTY) LTD was commissioned to conduct a quantitative risk assessment (QRA) to determine whether the facility would classify as a Major Hazard Installation (MHI) / have an impact onto surrounding properties and communities as part of an environmental impact assessment (EIA).

The purpose of this report is to convey the essential details, which include a short description of hazards, the receiving environment and the current relevant design, as well as risks and consequences of a major incident.

#### 1.1 Terms of Reference

The main aim of the investigation was to quantify the risks to employees, neighbours and the public with regard to the proposed CWA facility in Durbanville.

This risk assessment was to assess the risks posed by the fuels stored on the site. The scope of the risk assessment included:

1. Development of accidental spill and fire scenarios for the facility;
2. Using generic failure rate data (for tanks, pumps, valves, flanges, pipework, gantry, couplings and so forth), determination of the probability of each accident scenario;
3. For each incident developed in Step 2, determination of consequences (such as thermal radiation, domino effects, toxic-cloud formation and so forth);
4. For scenarios with off-site consequences (greater than 1% fatality off-site), calculation of maximum individual risk (MIR), taking into account all generic failure rates, initiating events (such as ignition), meteorological conditions and lethality.

## **1.2 Purpose and Main Activities**

The main activity at the proposed CWA facility in Durbanville is the air transportation of humans and goods. The process requires aircraft fuel that will be stored and transported on site.

## **1.3 Main Hazards Due to Substance and Process**

The main hazards that would occur with a loss of containment of hazardous components at the proposed CWA facility in Durbanville include exposure to:

- Thermal radiation from fires;
- Overpressure from explosions.

## 2 ENVIRONMENT

The proposed CWA facility, as shown in Figure 2-1, is located at Lichtenburg Road in Durbanville, Cape Town.

The coordinates of the airport are:

Latitude: 33°46'11.13" S

Longitude: 18°44'32.30" E

The CWA facility will be located approximately 33 km from Cape Town, with access from the R312 to the south of the airport. The facility is located in a rural area with mostly farmlands surrounding the facility. The residential area of Fisantekraal is located approximately 1.5 km to the south west of the airport and Mikipunt.

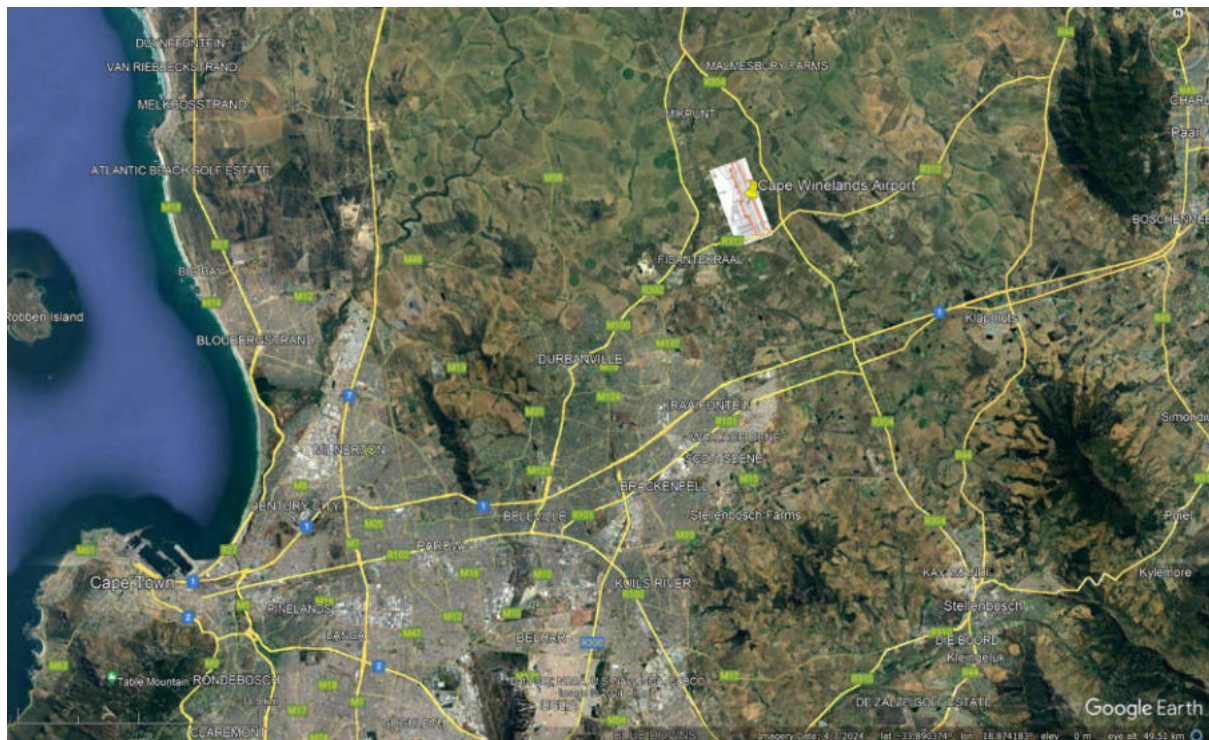

**Figure 2-1: Location of the proposed CWA facility in Durbanville**



### 3 PROJECT DESCRIPTION

#### 3.1 Site

The proposed CWA facility in Durbanville will consist of a runway, aircraft parking, hanger space, aircraft workshops, a passenger terminal, offices and infrastructure to sustain a mid-sized aircraft terminal. This risk assessment is primarily focused on the storage of hazardous fuels. Figure 3-1 indicates the conceptual layout of the proposed CWA facility with the location of the proposed aircraft fuel storage.

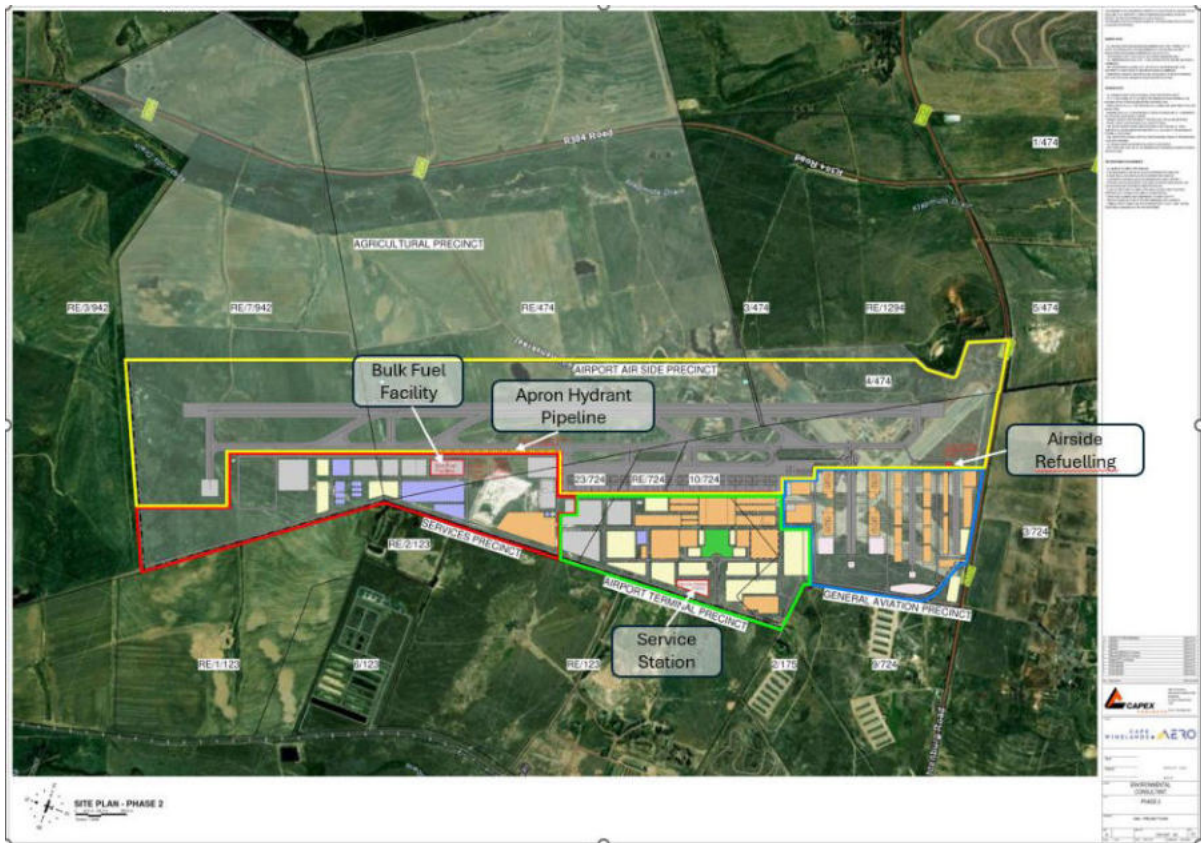

Figure 3-1: Site layout



The project is expected to be done in three phases, depending on the increased passenger and aircraft demand. The three phases of the fuel storage development are indicated in Figure 3-2 and Figure 3-3.

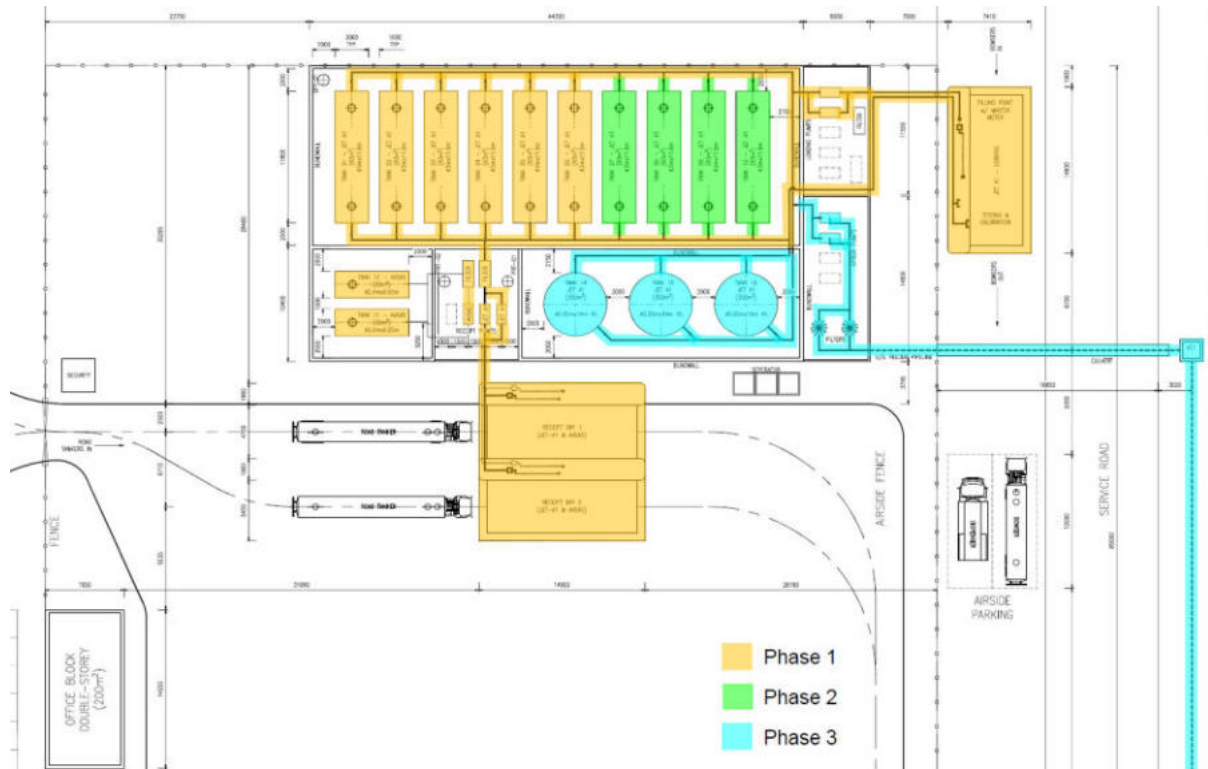

Figure 3-2: Proposed bulk fuel depot per phase

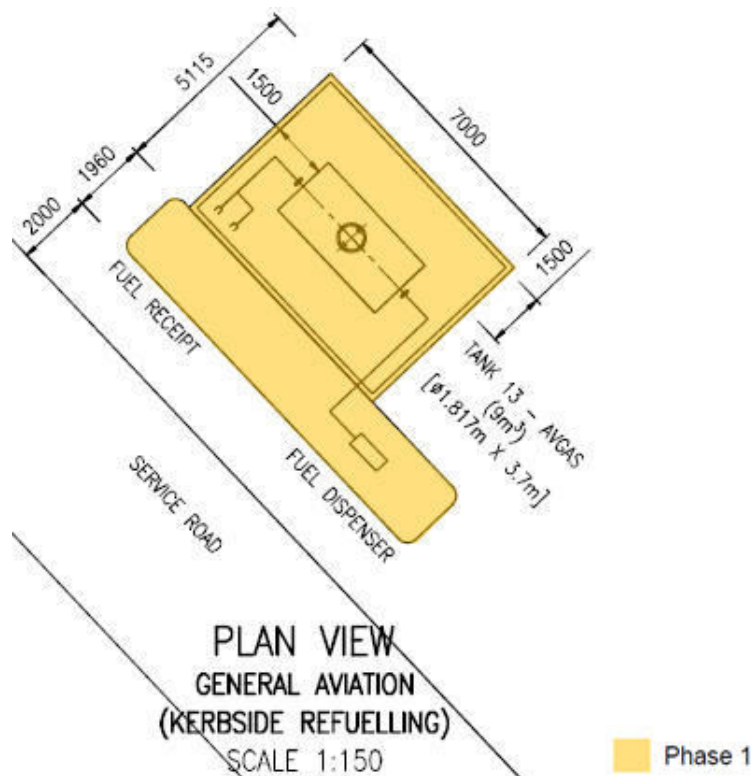

Figure 3-3: Proposed kerbside refuelling for Phase 1

## **3.2 Process Description**

It is anticipated that the proposed CWA facility may expand sometime in the future, including the increase on aviation fuel storage.

### **3.2.1 Road Receipt Facility**

All fuel will be received and offloaded by road tankers. Fuel will be ordered from the Astron Energy refinery in Milnerton, the storage terminals (BP or Engen) in Montague Gardens, or Burgan Cape Terminal at the Cape Town harbour. Deliveries should not take more than one day from when the order is placed.

The following are proposed to be built on site:

- Depot provided with a dedicated road receipt facility with entrance / exit for road tankers;
- Two receipt bays (both left-side offloading), each provided with 1 x receipt point (hoses and API dry-break couplers);
- Three receipt pumps;
- Provision for custody transfer metering;
- Provision to be made with a quick sampling tank for quality control;
- Two horizontal filter vessels (one for Jet A-1 and another for Avgas), each with a limiting capacity of 1 500 ℓ/min.

### **3.2.2 Jet A-1 Storage Tanks (Phase 1 to Phase 3)**

#### **3.2.2.1 Phase 1 (2029): Storage Tanks**

The storage tanks and associated infrastructure is described below:

- Phase 1 consists of 6 x horizontal tanks with a total gross storage capacity of 498 m<sup>3</sup> (sufficient to provide 7 x days buffer stock for the first 5 years of operation).
- Each tank will be provided with Automatic Tank Gauging (ATG) and independent overfilling protection.
- Each tank fitted with floating suction, sufficiently sized for at least 1 500 ℓ/min.
- The horizontal tanks will be provided with one shared Quick Flush Tank (QFTNo1).
- For secondary containment, the horizontal tanks (Jet A-1) all share a common bunded area with concrete floors and walls (the vertical tanks should be provided with their own).

#### **3.2.2.2 Phase 2 (2032): Storage Tanks**

The storage tanks and associated infrastructure is described below:

- Installation of 4 x horizontal tanks with a gross storage capacity of 332 m<sup>3</sup>, to bring the total installed capacity to 830 m<sup>3</sup>. The combined capacity should be sufficient to provide at least 7 x days buffer stock for the next 5 years of operation.

- Each tank will be provided with Automatic Tank Gauging (ATG) and independent overfilling protection.
- Each tank fitted with floating suction, sufficiently sized for at least 1 500 ℓ/min.
- The additional horizontal tanks will be provided with one shared Quick Flush Tank (QFTNo2).
- For secondary containment, the horizontal tanks (Jet A-1) all share a common bunded area with concrete floors and walls (the vertical tanks should be provided with their own).

### **3.2.2.3 Phase 3 (2038): Storage Tanks**

- Install additional 3 x vertical storage tanks, each with a gross capacity of 400 m<sup>3</sup>, to bring the total installed capacity to 1 850 m<sup>3</sup>.
- The combined capacity should be sufficient to provide at least 7 x days buffer stock for the next 20 years of operation.
- The tanks would be of the fixed roof type, constructed to API 650, with concrete foundation.
- Each tank fitted with floating suction, sufficiently sized for at least 3 000 ℓ/min.
- Each tank will be provided with Automatic Tank Gauging (ATG) and independent overfilling protection.
- The three vertical tanks will be provided with one dedicated Quick Flush Tank (QFTNo3).

### **3.2.3 Avgas Facilities**

The depot should also be provided with two double-walled horizontal tanks (Fireguard or similar type) for Avgas, with a total storage capacity of 60 m<sup>3</sup>. The tanks should be provided with pressure-vacuum vents and emergency vent bursting disks. The Avgas tanks will be located within their own bunded area, with concrete floors and walls. Avgas tanks are installed with a slope for water collection. Each tank is connected to a shared quick flush tank (QFTNo4). The Avgas receipt pump and filter (with a limiting capacity of 750 ℓ/min) could be located next to the road receipt facilities, next to the Jet A-1 pumps and filters.

The bulk receipt of Avgas and the filling of the bowser would be at the bulk fuel depot as described above. The same pump and filter will be used to fill bowsers.

### **3.2.4 Loading Area**

#### **3.2.4.1 Bowser Filling and Testing Facility**

For the first 15 years, it should be possible to deliver all fuels to the planes by means of the bowser and the related facilities as described below:

- The depot is provided with a dedicated bowser filling and testing facility with a separate entrance / exit for all bowsers.
- The facility is provided with two loading / filling pumps.

- One horizontal filter vessel (with a limiting capacity of 1 500 ℓ/min).
- The loading pumps is connected to a hydrant pit valve (located on the island).
- A bowser filling and testing facility will be provided with a quick sampling tank (quality control).

### **3.2.4.2 Apron Pipeline and Hydrant Pits**

From the year 2038 onwards, the fuel related infrastructure should supply between 156 and 219 kℓ/day (of Jet A-1) to about 34 x departing planes. This demand can be met with bowser vehicles; however, a roundtrip could be 20 minutes (travelling to the depot, connecting hoses, starting of the pump, filling the bowser, disconnect hoses, and return to the apron stands, etc.).

The proposed concept design includes the provision of a feeder pipeline (150 NB) to service the apron stands. Allow for a dedicated apron pump and vertical coalescer filters (with a total limiting capacity of 3 000 ℓ/min). The refuelling strategy (browsers only vs apron pipeline and hydrant pit valves) will be confirmed during the Detailed Engineering.

The fuel depot's apron pump and filter facilities are described below (For Phase 3 only):

- Two apron loading pumps.
- Two vertical filter vessels (one on duty / one on standby, each with a capacity of 3 000 ℓ/min).
- Filters provided with flow control valves on discharge to ensure regulated flow and limit linear velocities through filter cartridges.
- Valve chamber (VC1) with actuated expanding plug valves to quickly isolate the feeder pipeline in the event of an emergency (emergency shut-down valve, ESD).
- Valve chambers (VC2, VC3 and VC4) are provided with maintenance isolation valves.
- Allow for 11 x apron stands, each provided with a hydrant pit valve and isolation valve located in the 460 NB bottom-entry hydrant pit boxes (to standard EI 1584).
- Each pit valve to be provided with low-point drains and high-point vents.
- Based on the proposed routing of the feeder pipeline, the total linear length of the 150 NB pipeline is 1 910 m, terminating at VC4.

### **3.2.4.3 Vehicles on Site**

It is proposed that the airport should be serviced by:

- One 18 000 litre bowser truck (Jet A-1), with a filling rate of approximately 650 ℓ/min.
- One 9 000 litre bowser truck (Jet A-1), with a filling rate of approximately 450 ℓ/min.
- One 4 500 litre bowser truck (Avgas), with a filling rate of approximately 450 ℓ/min.
- One dispenser vehicle (also known as a hydrant servicer), with a filling rate of approximately 1 800 ℓ/min (only if the feeder pipeline and hydrant pits are installed).
- A slops trailer to collect from the pipeline low-points (also, only required if the feeder pipeline and hydrant pits are installed).

### 3.3 Summary of Bulk Materials to be Stored on Site

A summary of bulk materials that can give hazardous effects that are to be stored on site is given below.

#### 3.3.1 Fuel Storage at the end of Phase 1

**Table 3-1: Summary of Jet A-1 to be stored on site at the end of Phase 1**

Tank No.	Type	Diameter (m)	Length (m)	Design (m <sup>3</sup> )	Bunded Area (m <sup>2</sup> )	Bund Volume (m <sup>3</sup> )
01	Horizontal atmospheric tanks with supporting cradles	3.0	11.8	83	Single bunded	Bund height of 1.6 m (Assumed)
02		3.0	11.8	83		
03		3.0	11.8	83		
04		3.0	11.8	83		
05		3.0	11.8	83		
06		3.0	11.8	83		
<b>TOTAL</b>				<b>498</b>	<b>680</b>	<b>1 087</b>
<b>TOTAL (t)</b>				<b>398.4</b>		

**Table 3-2: Summary of Avgas to be stored on site at the end of Phase 1**

Tank No.	Type	Diameter (m)	Length (m)	Design (m <sup>3</sup> )	Bunded Area (m <sup>2</sup> )	Bund Volume (m <sup>3</sup> )
11	Horizontal atmospheric tanks.	2.3	7.45	30	105	169
12		2.3	7.45	30		
13	Double-walled tank (Fireguard or similar type)	1.82	3.70	9	35	56
<b>TOTAL</b>				<b>69</b>		
<b>TOTAL (t)</b>				<b>48.3</b>		

### 3.3.2 Fuel Storage at the end of Phase 2

**Table 3-3: Summary of Jet A-1 to be stored on site at the end of Phase 2**

Tank No.	Type	Diameter (m)	Length (m)	Design (m <sup>3</sup> )	Bunded Area (m <sup>2</sup> )	Bund Volume (m <sup>3</sup> )
01	Horizontal atmospheric tanks with supporting cradles	3.0	11.8	83	Single bunded	Bund height of 1.6 m (Assumed)
02		3.0	11.8	83		
03		3.0	11.8	83		
04		3.0	11.8	83		
05		3.0	11.8	83		
06		3.0	11.8	83		
07		3.0	11.8	83		
08		3.0	11.8	83		
09		3.0	11.8	83		
10		3.0	11.8	83		
				<b>TOTAL</b>	<b>830</b>	<b>680</b>
				<b>TOTAL (t)</b>	<b>664</b>	<b>1 087</b>

**Table 3-4: Summary of Avgas to be stored on site at the end of Phase 2**

Tank No.	Type	Diameter (m)	Length (m)	Design (m <sup>3</sup> )	Bunded Area (m <sup>2</sup> )	Bund Volume (m <sup>3</sup> )
11	Horizontal atmospheric tanks.	2.3	7.45	30	105	169
12		2.3	7.45	30		
13	Double-walled tank (Fireguard or similar type)	1.82	3.70	9	35	56
				<b>TOTAL</b>	<b>69</b>	
				<b>TOTAL (t)</b>	<b>48.3</b>	

### 3.3.3 Fuel Storage at the end of Phase 3

**Table 3-5: Summary of Jet A-1 to be stored on site at the end of Phase 3**

Tank No.	Type	Diameter (m)	Length (m)	Design (m <sup>3</sup> )	Bunded Area (m <sup>2</sup> )	Bund Volume (m <sup>3</sup> )
01	Horizontal atmospheric tanks with supporting cradles	3.0	11.8	83	680	1 087
02		3.0	11.8	83		
03		3.0	11.8	83		
04		3.0	11.8	83		
05		3.0	11.8	83		
06		3.0	11.8	83		
07		3.0	11.8	83		
08		3.0	11.8	83		
09		3.0	11.8	83		
10		3.0	11.8	83		
14	Vertical storage tank with concrete foundation	5.65	14.0	400		
15		5.65	14.0	400		
16		5.65	14.0	400		
<b>TOTAL</b>				<b>2 030</b>		
<b>TOTAL (t)</b>				<b>1 864</b>		

**Table 3-6: Summary of Avgas to be stored on site at the end of Phase 3**

Tank No.	Type	Diameter (m)	Length (m)	Design (m <sup>3</sup> )	Bunded Area (m <sup>2</sup> )	Bund Volume (m <sup>3</sup> )
11	Horizontal atmospheric tanks.	2.3	7.45	30	105	169
12		2.3	7.45	30		
13	Double-walled tank (Fireguard or similar)	1.82	3.70	9	35	56
<b>TOTAL</b>				<b>69</b>		
<b>TOTAL (t)</b>				<b>48.3</b>		



## 4 METHODOLOGY

The first step in any risk assessment is to identify all hazards. The merit of including a hazard for further investigation is then determined by how significant it is, normally by using a cut-off or threshold value.

Once a hazard has been identified, it is necessary to assess it in terms of the risk it presents to the employees and the neighbouring community. In principle, both probability and consequence should be considered, but there are occasions where, if either the probability or the consequence can be shown to be sufficiently low or sufficiently high, decisions can be made based on just one factor.

During the hazard identification component of the report, the following considerations are taken into account:

- Chemical identities;
- Location of on-site installations that use, produce, process, transport or store hazardous components;
- Type and design of containers, vessels or pipelines;
- Quantity of material that could be involved in an airborne release;
- Nature of the hazard most likely to accompany hazardous materials spills or releases, e.g., airborne toxic vapours or mists, fires or explosions, large quantities to be stored and certain handling conditions of processed components.

The evaluation methodology assumes that the facility will perform as designed in the absence of unintended events such as component and material failures of equipment, human errors, external events and process unknowns.

Due to the absence of the South African legislation regarding the determination of methodology for quantitative risk assessment (QRA), the methodology of this assessment is based on the legal requirements of the Netherlands, outlined in CPR 18E (Purple Book; 1999) and RIVM (2009). The evaluation of the acceptability of the risks is done in accordance with the UK Health and Safety Executive (HSE) ALARP criteria that clearly cover land use, based on determined risks.

The QRA process is summarised with the following steps:

1. Identification of components that are flammable, toxic, reactive or corrosive and that have the potential to result in a major incident from fires, explosions or toxic releases;
2. Development of accidental loss of containment (LOC) scenarios for equipment containing hazardous components (including release rate, location and orientation of release);
3. For each incident developed in Step 2, determination of consequences (such as thermal radiation, domino effects, toxic-cloud formation and so forth);
4. For scenarios with off-site consequences (greater than 1% fatality off-site), calculation of maximum individual risk (MIR), taking into account all generic failure rates, initiating events (such as ignition), meteorological conditions and lethality.

Scenarios included in this QRA have impacts externally to the establishment. The 1% fatality from acute effects (thermal radiation, blast overpressure and toxic exposure) is determined as the endpoint (RIVM 2009). Thus, a scenario producing a fatality of less than 1% at the establishment boundary under worst-case meteorological conditions, would be excluded from the QRA.

## **5 CONCLUSIONS**

Risk calculations are not precise. Accuracy of predictions is determined by the quality of base data and expert judgements.

This risk assessment included the consequences of fires and explosions at the proposed CWA facility in Durbanville. A number of well-known sources of incident data were consulted and applied to determine the likelihood of an incident to occur.

This risk assessment was performed with the assumption that the site would be maintained to an acceptable level and that all statutory regulations would be applied. It was also assumed that the detailed engineering designs would be done by competent people and would be correctly specified for the intended duty. For example, it was assumed that tank wall thicknesses have been correctly calculated, that vents have been sized for emergency conditions, that instrumentation and electrical components comply with the specified electrical area classification, that material of construction is compatible with the products, etc.

It is the responsibility of the owners and their contractors to ensure that all engineering designs would have been completed by competent persons and that all pieces of equipment would have been installed correctly. All designs should be in full compliance with (but not limited to) the Occupational Health and Safety Act 85 of 1993 and its regulations, the National Buildings Regulations and the Buildings Standards Act 107 of 1977, as well as the local bylaws.

A number of incident scenarios were simulated, taking into account the prevailing meteorological conditions, and described in the report.

### **5.1 Hazardous Materials**

The hazardous materials identified included Jet A-1 and Avgas fuels. Both these materials are considered flammable, but not acutely toxic when inhaled.

### **5.2 Notifiable Substances**

The General Machinery Regulation 8 and its Schedule A on notifiable substances requires any employer who has a substance equal to or exceeding the quantity listed in the regulation to notify the divisional director. A site is classified as a Major Hazard Installation if it contains one or more notifiable substances or if the off-site risk is sufficiently high. The latter can only be determined from a quantitative risk assessment.

No material to be stored on site is listed as notifiable.

### **5.3 Bulk Fuel Tank Farm**

Pool fires and flash fires from a loss of containment at the storage and offloading installations of Jet A-1 and Avgas and subsequent fires were simulated. Tank explosions from Avgas were also simulated.

The 1% fatality for Avgas and Jet A-1 from fires, could extend a short distance over the tank farm boundary. However, these impacts would not extend to areas occupied by the general public or to the runway and airplanes.

#### 5.4 Avgas Kerbside Filling

The kerbside filling will consist of a 9 m<sup>2</sup> Avgas tank with an offloading area.

Pool fires from a loss of containment would extend beyond the secondary containment, but would not extend to the area occupied by the general public.

Risks greater than 1x10<sup>-4</sup> fatalities per person per year, are considered tolerable for industrial areas, but excessive for residential areas. The 1x10<sup>-4</sup> fatalities per person per year did not extend into areas occupied by the general public on the proposed CWA site.

The risk of 3x10<sup>-7</sup> fatalities per person per year isopleth indicates the extent for land-use that would be suitable for vulnerable populations, such as hospitals, retirement homes, nursery schools, prisons, large gatherings in the open, and so forth. As the risks did not extend into areas occupied by the general public, no land planning would be required.

The risk from the kerbside filling would be considered acceptable.

#### 5.5 Apron Pipeline

The apron pipeline is expected to be constructed during Phase 3. The pipeline would be located in a chamber. Thus, a loss of containment will firstly fill the chamber and then overflow. For this study, the maximum area from a pool formed from a loss of containment was limited to 300 m<sup>2</sup>.

The 1% fatality from the apron pipeline could extend 41 m from the pipeline. However, the risks from the apron pipeline failure would be considered acceptable.

#### 5.6 Impacts onto Neighbouring Properties, Residential Areas and MHIs

Impacts from Jet A-1 and Avgas would not extend into areas occupied by the general public.

#### 5.7 Major Hazard Installation

The expected MHI hazard tier for each phase of the fuel storage projects, is given in Table 8-1.

**Table 8-1: Expected establishment hazardous tier per project phase**

Phase	Avgas Inventory (t)	Jet A-1 Inventory (t)	Total (t)	Hazard Tier
1	394.2	48.3	442.5	Low Hazard
2	664	48.3	712.3	Low Hazard
2	1864	38.3	1 902.3	Low Hazard

The requirements of approvals and registration under the MHI regulations should be reviewed for adequate preparation in completing the MHI risk assessment, as required by legislation prior to construction.

## 6 RECOMMENDATIONS

As a result of the risk assessment study conducted for the proposed CWA facility in Durbanville a number of events were found to have risks beyond the fuel tank farm boundary. These risks could be mitigated to acceptable levels, as shown in the report.

RISCOM did not find any fatal flaws that would prevent the project proceeding to the detailed engineering phase of the project.

RISCOM would support the project with the following conditions:

- Compliance with all statutory requirements, i.e., pressure vessel designs;
- Compliance with applicable SANS codes, i.e., SANS 10087, SANS 10089, SANS 10108, etc.;
- Incorporation of applicable guidelines or equivalent international recognised codes of good design and practice into the designs;
- Completion of a recognised process hazard analysis (such as a HAZOP study, FMEA, etc.) on the proposed facility prior to construction to ensure that the design and operational hazards have been identified and adequate mitigation are put in place;
- Full compliance with IEC 61511 (Safety Instrument Systems) standards or equivalent to ensure that adequate protective instrumentation is included in the design and would remain valid for the full life cycle of the tank farm: This is particularly relevant to the overfilling of the storage tanks and applicable shutdown systems:
  - Including demonstration from the designer that sufficient and reliable instrumentation would be specified and installed at the facility;
- Preparation and issuing of a safety document detailing safety and design features reducing the impacts from fires, explosions and flammable atmospheres to the MHI assessment body at the time of the MHI assessment:
  - Including compliance to statutory laws, applicable codes and standards and world's best practice;
  - Including the listing of statutory and non-statutory inspections, giving frequency of inspections;
  - Including the auditing of the built facility against the safety document;
  - Noting that codes such as IEC 61511 can be used to achieve these requirements;
- Demonstration by CWA or their contractor that the final designs would reduce the risks posed by the installation to internationally acceptable guidelines;
- Signature of all terminal designs by a professional engineer registered in South Africa in accordance with the Professional Engineers Act, who takes responsibility for suitable designs;
- Completion of an emergency preparedness and response document for on-site and off-site scenarios prior to initiating the MHI risk assessment (with input from the local authorities);
- Permission not being granted for increases to the product list or product inventories without redoing part of or the full EIA;
- Final acceptance of the facility risks with an MHI risk assessment that must be completed in accordance to the MHI regulations:
  - Basing such a risk assessment on the final design and including engineering mitigation.

## Table of Contents

1	INTRODUCTION.....	1-1
1.1	Legislation.....	1-1
1.1.1	National Environmental Management Act (No. 107 of 1998) (NEMA) and its Regulations.....	1-1
1.1.2	The Occupational Health and Safety Act No. 85 of 1993.....	1-3
1.2	Terms of Reference.....	1-4
1.3	Purpose and Main Activities.....	1-4
1.4	Limitations and Assumptions.....	1-4
1.5	Main Hazards Due to Substance and Process.....	1-4
1.6	Software.....	1-4
2	ENVIRONMENT.....	2-1
2.1	General Background.....	2-1
2.2	Meteorology.....	2-2
2.2.1	Surface Winds.....	2-3
2.2.2	Precipitation and Relative Humidity.....	2-4
2.2.3	Temperature.....	2-5
2.2.4	Atmospheric Stability.....	2-6
2.2.5	Meteorological Simulation Values.....	2-7
3	PROJECT DESCRIPTION.....	3-1
3.1	Site.....	3-1
3.2	Process Description.....	3-3
3.2.1	Road Receipt Facility.....	3-3
3.2.2	Jet A-1 Storage Tanks (Phase 1 to Phase 3).....	3-3
3.2.3	Avgas Facilities.....	3-4
3.2.4	Loading Area.....	3-4
3.3	Summary of Bulk Materials to be Stored on Site.....	3-6
3.3.1	Fuel Storage at the end of Phase 1.....	3-6
3.3.2	Fuel Storage at the end of Phase 2.....	3-7
3.3.3	Fuel Storage at the end of Phase 3.....	3-8
3.4	Establishment Tier.....	3-9
4	HAZARD IDENTIFICATION.....	4-1
4.1	Notifiable Substances.....	4-1
4.2	Substance Hazards.....	4-2
4.2.1	Chemical Properties.....	4-2
4.2.2	Corrosive Liquids.....	4-3
4.2.3	Reactive Components.....	4-3
4.2.4	Flammable and Combustible Components.....	4-3
4.3	Physical Properties.....	4-4
5	PHYSICAL AND CONSEQUENCE MODELLING.....	5-1
5.1	Multiple Consequence Scenarios.....	5-2
5.1.1	Continuous Release of a Flammable Liquid.....	5-2
5.2	Fires.....	5-3

5.2.1	Thermal Radiation .....	5-3
5.2.2	Bund and Pool Fires.....	5-4
5.3	Apron Pipeline.....	5-7
5.3.1	Tank-Top Fires .....	5-8
5.3.2	Jet Fires.....	5-9
5.3.3	Flash Fires.....	5-9
5.4	Explosions.....	5-10
5.4.1	Vapour Cloud Explosions (VCEs).....	5-13
5.4.2	Fixed-Roof Tank Explosions .....	5-14
5.4.3	Boiling Liquid Expanding Vapour Explosions (BLEVEs) .....	5-15
5.5	Summary of Impacts.....	5-16
6	RISK ANALYSIS .....	6-1
6.1	Background.....	6-1
6.2	Predicted Risk.....	6-2
6.2.1	Generic Equipment Failure Scenarios .....	6-3
6.3	Risk Calculations .....	6-9
6.3.1	Maximum Individual Risk Parameter .....	6-9
6.3.2	Acceptable Risks.....	6-9
6.3.3	Land Planning .....	6-12
6.4	Risk Scenarios .....	6-14
6.4.1	Lethal Dosages from Accidental Toxic Releases .....	6-14
6.4.2	Accidental Fires and Explosions.....	6-14
7	REDUCTION OF RISK.....	7-1
7.1	Mitigation.....	7-1
7.1.1	Containment .....	7-1
7.1.2	Overfilling.....	7-1
7.1.3	Process Hazard Analysis (PHA) .....	7-1
7.1.4	Ignition Sources.....	7-2
7.1.5	Emergency Shut Down System (ESD) .....	7-2
7.1.6	Codes and Standards .....	7-2
7.1.7	Safety Instrumented Systems .....	7-2
8	CONCLUSIONS .....	8-1
8.1	Hazardous Materials.....	8-1
8.2	Notifiable Substances .....	8-1
8.3	Bulk Fuel Tank Farm .....	8-1
8.4	Avgas Kerbside Filling .....	8-2
8.5	Apron Pipeline.....	8-2
8.6	Impacts onto Neighbouring Properties, Residential Areas and Major Hazard Installations .....	8-2
8.7	Major Hazard Installation .....	8-3
9	RECOMMENDATIONS .....	9-1
10	REFERENCES.....	10-1
11	ABBREVIATIONS AND ACRONYMS .....	11-1
12	APPENDIX A: NOTIFICATION OF MAJOR HAZARD INSTALLATION .....	12-1



13	APPENDIX B: PADHI LAND-PLANNING TABLES.....	13-1
13.1	Development Type Table 1: People at Work, Parking.....	13-1
13.2	Development Type Table 2: Developments for Use by the General Public .....	13-2
13.3	Development Type Table 3: Developments for Use by Vulnerable People .....	13-6
13.4	Development Type Table 4: Very Large and Sensitive Developments.....	13-7
14	APPENDIX C: INCIDENT SCENARIOS.....	14-1
14.1	Pool Fires.....	14-1
14.1.1	Tank – Catastrophic failure .....	14-1
14.1.2	Tank – Severe Leak Failure.....	14-2
14.1.3	Tank Overfilling .....	14-3
14.1.4	Tank Top Fires .....	14-4
14.1.5	Tank Explosions.....	14-5
14.1.6	Road Tanker Loading / Offloading.....	14-6
15	APPENDIX D: PROOF OF COMPETANCY.....	15-1
15.1	Department of Employment and Labour Certificate.....	15-1
15.2	SANAS Certificate .....	15-2
15.3	Scope of Accreditation.....	15-3
16	APPENDIX E: MATERIAL SAFETY DATA SHEETS.....	16-1
16.1	Jet A-1 / Kerosene (UN No. 1863) .....	16-1
16.2	Avgas (UN No. 1203).....	16-2

## List of Figures

Figure 2-1:	Location of the proposed CWA facility in Durbanville.....	2-1
Figure 2-2:	Wind analysis over the period from 2018 to 2022 .....	2-3
Figure 2-3:	Representative weather classes for Cape Town (2018–2022) .....	2-7
Figure 3-1:	Site layout.....	3-1
Figure 3-2:	Proposed bulk fuel depot per phase .....	3-2
Figure 3-3:	Proposed kerbside refuelling for Phase 1 .....	3-2
Figure 5-1:	Event tree for a continuous release of a flammable liquid .....	5-2
Figure 5-2:	The 1% fatality from various pool fire scenarios at the fuel tank farm .....	5-5
Figure 5-3:	The 1% fatality from various pool fire scenarios at the kerbside refuelling....	5-6
Figure 5-4:	The 1% fatality from a Jet A-1 pool fire from a loss of containment of the Jet A-1 apron pipeline .....	5-7
Figure 5-5:	Side view of the thermal radiation from large Jet A-1 tank-top fires in the storage area .....	5-8
Figure 5-6:	Blast overpressure from a single fixed-roof tank explosion in the Avgas storage area .....	5-14
Figure 6-1:	UK HSE decision-making framework.....	6-10
Figure 6-2:	Town-planning zones for pipelines .....	6-12
Figure 6-3:	Town-planning zones .....	6-13
Figure 6-4:	Lethal probability isopleths associated with the fuel storage tank farm at the end of Phase 1 .....	6-15
Figure 6-5:	Lethal probability isopleths associated with the Avgas kerbside installation the end of Phase 1 .....	6-16
Figure 6-6:	Lethal probability isopleths associated with the fuel storage tank farm the end of Phase 2 .....	6-17
Figure 6-7:	Lethal probability isopleths associated with the fuel storage tank farm the end of Phase 3 .....	6-18

## List of Tables

Table 2-1:	Long-term average precipitation and relative humidity for Cape Town .....	2-4
Table 2-2:	Long-term temperature averages for Cape Town .....	2-5
Table 2-3:	Classification scheme for atmospheric stability .....	2-6
Table 2-4:	Representative weather classes .....	2-6
Table 2-5:	Allocation of observations into six weather classes .....	2-6
Table 2-6:	Default meteorological values used in simulations, based on local conditions .....	2-7
Table 3-1:	Summary of Jet A-1 to be stored on site at the end of Phase 1 .....	3-6
Table 3-2:	Summary of Avgas to be stored on site at the end of Phase 1 .....	3-6
Table 3-3:	Summary of Jet A-1 to be stored on site at the end of Phase 2 .....	3-7
Table 3-4:	Summary of Avgas to be stored on site at the end of Phase 2 .....	3-7
Table 3-5:	Summary of Jet A-1 to be stored on site at the end of Phase 3 .....	3-8
Table 3-6:	Summary of Avgas to be stored on site at the end of Phase 3 .....	3-8
Table 3-7:	Summary of the hazard tier related from the inventory stored .....	3-9
Table 3-8:	Expected establishment hazardous tier per project phase .....	3-9
Table 4-1:	Flammable and combustible substances to be stored on, produced at or delivered to site .....	4-3
Table 4-2:	Representative components .....	4-4
Table 5-1:	Thermal radiation guidelines (BS 5980 of 1990) .....	5-3
Table 5-2:	Summary of consequences of blast overpressure (Clancey 1972) .....	5-11
Table 5-3:	Damage caused by overpressure effects of an explosion (Stephens 1970) .....	5-12
Table 5-4:	Maximum distance to 1% fatality from the point of release .....	5-16
Table 6-1:	Influence of public perception of risk on acceptance of that risk, based on the POST report .....	6-1
Table 6-2:	Failure frequencies for atmospheric vessels .....	6-3
Table 6-3:	Failure frequencies for pressure vessels .....	6-3
Table 6-4:	Failure frequencies for process pipes .....	6-4
Table 6-5:	Failure frequencies for aboveground transport pipelines .....	6-4
Table 6-6:	Failure frequencies for underground transport pipelines .....	6-4
Table 6-7:	Failure frequency for centrifugal pumps and compressors .....	6-5
Table 6-8:	Failure frequency for reciprocating pumps and compressors .....	6-5
Table 6-9:	Failure frequencies for loading and offloading arms and hoses .....	6-5
Table 6-10:	Failure frequencies for road tankers with an atmospheric tank .....	6-6
Table 6-11:	Failure frequencies for road tankers with a pressurised tank .....	6-6
Table 6-12:	Human failure rates of specific types of tasks (CPR 12E 2005; Red Book) .....	6-7
Table 6-13:	Probability of direct ignition for stationary installations (RIVM 2009) .....	6-8
Table 6-14:	Classification of flammable substances .....	6-8
Table 6-15:	Land-use decision matrix .....	6-13
Table 8-1:	Expected establishment hazardous tier per project phase .....	8-3

# QUANTITATIVE RISK ASSESSMENT OF THE PROPOSED FUEL STORAGE PROJECT AT THE CAPE WINELANDS AIRPORT IN DURBANVILLE, CAPE TOWN

## 1 INTRODUCTION

The Cape Winelands Airport (hereinafter referred to as CWA) has purchased Fisantekraal Airport in Durbanville and is planning to upgrade the airport to accommodate commercial air traffic. As part of the upgrade, aircraft fuel tanks would need to be installed.

Since off-site incidents may result due to hazards of some of the fuels to be stored on, produced at or delivered to site, RISCOM (PTY) LTD was commissioned to conduct a quantitative risk assessment (QRA) to determine whether the facility would classify as a Major Hazard Installation (MHI) / have an impact onto surrounding properties and communities as part of an environmental impact assessment (EIA).

The purpose of this report is to convey the essential details, which include a short description of hazards, the receiving environment and the current relevant design, as well as risks and consequences of a major incident.

### 1.1 Legislation

Legislation discussed in this subsection is limited to the health and safety of employees and the public.

Risk assessments are conducted when required to do so by law or by companies wishing to determine the risks of the facility for other reasons, such as insurance. In South Africa, risk assessments are carried out under the legislation of two separate acts, each with different requirements. These are discussed in the subsections that follow.

#### 1.1.1 National Environmental Management Act (No. 107 of 1998) (NEMA) and its Regulations

The National Environmental Management Act (NEMA) contains South Africa's principal environmental legislation. It has, as its primary objective, to make provision for cooperative governance by establishing principles for decision making on matters affecting the environment, on the formation of institutions that will promote cooperative governance and on establishing procedures for coordinating environmental functions exercised by organs of the state, as well as to provide for matters connected therewith (Government Gazette 1998).

Section 30 of the NEMA act deals with the control of emergency incidents where an “incident” is defined as an “*unexpected sudden occurrence, including a major emission, fire or explosion leading to serious danger to the public or potentially serious pollution of or detriment to the environment, whether immediate or delayed*”.

The act defines “pollution” as “*any change in the environment caused by:*

- (i) *Substances;*
- (ii) *Radioactive or other waves; or,*
- (iii) *Noise, odours, dust or heat...*

*Emitted from any activity, including the storage or treatment of waste or substances, construction and the provision of services, whether engaged in by any person or an organ of state, where that change has an adverse effect on human health or wellbeing or on the composition, resilience and productivity of natural or managed ecosystems, or on materials useful to people, or will have such an effect in the future...* ”

**“Serious” is not fully defined, but would be accepted as having long lasting effects that could pose a risk to the environment or to the health of the public that is not immediately reversible.**

This is similar to the definition of a MHI as defined in the Occupational Health and Safety Act (OHS Act) 85 of 1993 and its MHI regulations.

Section 28 of NEMA makes provision for anyone who causes pollution or degradation of the environment being made responsible for the prevention of the occurrence, continuation or reoccurrence of related impacts and for the costs of repair of the environment. In terms of the provisions under Section 28 that are stated as:

“ *Every person who causes, has caused or may cause significant pollution or degradation of the environment must take reasonable measures to prevent such pollution or degradation from occurring, continuing or recurring, or, in so far as such harm to the environment is authorised by law or cannot reasonably be avoided or stopped...* ”

### **1.1.2 The Occupational Health and Safety Act No. 85 of 1993**

The Occupational Health and Safety Act 85 (1993) is primarily intended for the health and safety of the employees, whereas its MHI regulations is intended for the health and safety of the public.

The OHS Act shall not apply in respect of:

- “
- a) *A mine, a mining area or any works as defined in the Minerals Act, 1991 (Act No. 50 of 1991), except in so far as that Act provides otherwise;*
  - b) *Any load line ship (including a ship holding a load line exemption certificate), fishing boat, sealing boat and whaling boat as defined in Section 2 (1) of the Merchant Shipping Act, 1951 (Act No. 57 of 1951), or any floating crane, whether or not such ship, boat or crane is in or out of the water within any harbour in the Republic or within the territorial waters thereof, (date of commencement of paragraph (b) to be proclaimed.), or in respect of any person present on or in any such mine, mining area, works, ship, boat or crane.*”

#### **1.1.2.1 Major Hazard Installation Regulations**

Concern about the health and safety of the public has led to the regulation of handling, storage and the use of industrial chemicals. On the 16<sup>th</sup> of January 1998, the Major Hazard Installation regulations were promulgated under the Occupational Health and Safety Act (Act No. 85 of 1993; hereinafter referred to as the OHS Act), with a further amendment on the 30<sup>th</sup> of July 2001.

On the 31<sup>st</sup> of January 2023, new MHI regulations were gazetted, whereby the facility would be classified based on the amount of hazardous products stored on site. The threshold values for these hazardous products are defined within the Regulations.

In accordance with legislation, the risk assessment must be done by an approved inspection authority (AIA), which is registered with the Department of Employment and Labour and accredited by the South African Accreditation Systems (SANAS). Furthermore, the Engineering Professional Act 114 of 2000, requires all persons conducting engineering work to be registered with the Engineering Council of South Africa and may not perform work outside of their field of registration. Copies of the relevant certificates are given in Section 15.

This report contains information summaries with a special focus on QRA and with comment on on-site emergency plans. The requirements, following an incident and the general duties required from the supplier and local government will merely be repeated from the regulations.

## **1.2 Terms of Reference**

The main aim of the investigation was to quantify the risks to employees, neighbours and the public with regard to the proposed CWA facility in Durbanville.

This risk assessment was to assess the risks posed by the fuels stored on the site. The scope of the risk assessment included:

1. Development of accidental spill and fire scenarios for the facility;
2. Using generic failure rate data (for tanks, pumps, valves, flanges, pipework, gantry, couplings and so forth), determination of the probability of each accident scenario;
3. For each incident developed in Step 2, determination of consequences (such as thermal radiation, domino effects, toxic-cloud formation and so forth);
4. For scenarios with off-site consequences (greater than 1% fatality off-site), calculation of maximum individual risk (MIR), taking into account all generic failure rates, initiating events (such as ignition), meteorological conditions and lethality.

## **1.3 Purpose and Main Activities**

The main activity at the proposed CWA facility in Durbanville is the air transportation of humans and goods. The process requires aircraft fuel that will be stored and transported on site.

## **1.4 Limitations and Assumptions**

The risk assessment was developed based on the information provided by CWA. These designs are conceptual and does not include detailed designs, which will be completed before construction. Thus, some information, as required by the risk assessment simulations, were assumed and based on similar installations. However, it is assumed that the relatively large storage tanks will determine the endpoints from a release and will be the major contributor towards the risks generated. To this end, the results obtained in this report may lack the accuracy of a detailed engineered plant. However, the risks generated are expected to represent the facility, provided the vessel size and inventory are not increased.

The risk assessment is limited to the fuel storage of Avgas and Jet A-1 fuels located on the proposed CWA site.

## **1.5 Main Hazards Due to Substance and Process**

The main hazards that would occur with a loss of containment of hazardous components at the proposed CWA facility in Durbanville include exposure to:

- Thermal radiation from fires;
- Overpressure from explosions.

## **1.6 Software**

Physical consequences were calculated with Gexcon's Riskcurves version 12.3.0, and the data derived was copied to the initial report. All calculations were performed by Mr M P Oberholzer.



## 2 ENVIRONMENT

### 2.1 General Background

The proposed CWA facility, as shown in Figure 2-1, is located at Lichtenburg Road in Durbanville, Cape Town.

The coordinates of the airport are:

Latitude: 33°46'11.13" S

Longitude: 18°44'32.30" E

The CWA facility will be located approximately 33 km from Cape Town, with access from the R312 to the south of the airport. The facility is located in a rural area with mostly farmlands surrounding the facility. The residential area of Fisantekraal is located approximately 1.5 km to the south west of the airport and Mikpunt.

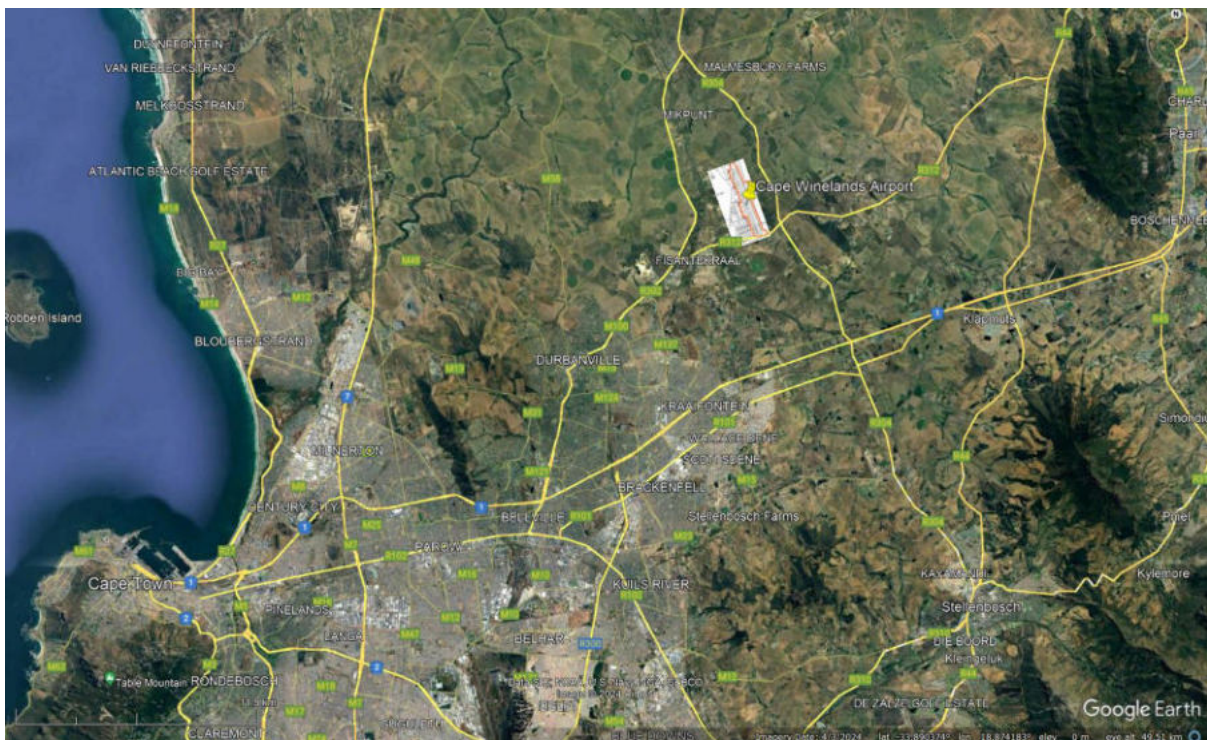

Figure 2-1: Location of the proposed CWA facility in Durbanville

## **2.2 Meteorology**

Meteorological mechanisms govern dispersion, transformation and the eventual removal of hazardous vapours from the atmosphere. The extent to which hazardous vapours will accumulate or disperse in the atmosphere is dependent on the degree of thermal and mechanical turbulence within the earth's boundary layer.

Dispersion comprises of vertical and horizontal components of motion. The stability and the depth of the atmosphere from the surface (known as the mixing layer) defines the vertical component. The horizontal dispersion of hazardous vapours in the atmospheric boundary layer is primarily a function of wind field. Wind speed determines both the distance of downwind transport and the rate of dilution as a result of stretching of the plume, and where the generation of mechanical turbulence is a function of the wind speed in combination with surface roughness. Wind direction and variability in wind direction both determine the general path of hazardous vapours that will follow and the extent of crosswinds spreading.

Concentration levels of hazardous vapours therefore fluctuate in response to changes in the atmospheric stability, to concurrent variations in the mixing layer depth and to shifts in the wind field.

For this report, the meteorological conditions at the Cape Town International Airport as measured by the South African Weather Service, were used as the basis of wind speed and direction and the atmospheric stability.

### 2.2.1 Surface Winds

Hourly averages of wind speed and direction recorded at the Cape Town International Airport were obtained from the South African Weather Service for the period from the 1<sup>st</sup> of January 2018 to the 31<sup>st</sup> of December 2022.

The wind roses in Figure 2-2 depict the annual wind frequency pattern for the Cape Town International Airport. Calm conditions were measured at 4.2% most of the time with the predominant wind speed from the south.

Cape Town experiences mostly medium wind speeds, but can experience occasional high wind speeds.

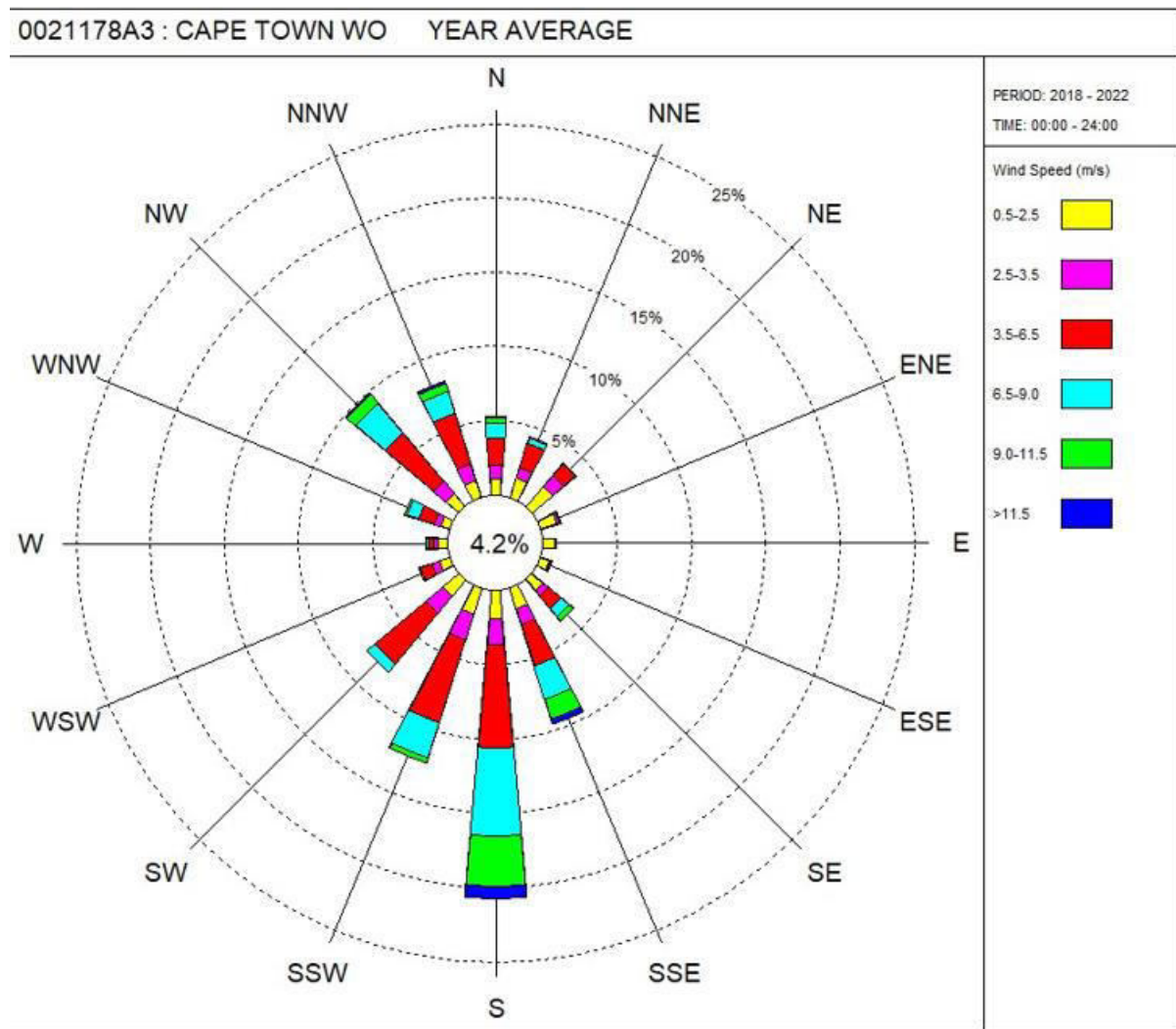

Figure 2-2: Wind analysis over the period from 2018 to 2022

## 2.2.2 Precipitation and Relative Humidity

The long-term rainfall and relative humidity recorded at the Cape Town International Airport was obtained from the South African Weather Service for the period from 1991 to 2020, as given in Table 2-1.

Cape Town is relatively dry, with an average annual rainfall of 492 mm and the dry season ranging from November to March.

The relative humidity typically ranges from 24% (dry) to 97% (very humid) over the course of the year, rarely dropping below 29% (dry) and reaching as high as 100% (very humid).

The air is the driest in and around December, at which time the relative humidity drops below 51% (mildly humid) three days out of four. It is most humid in and around July, exceeding 95% (very humid) three days out of four.

**Table 2-1: Long-term average precipitation and relative humidity for Cape Town**

Month	Relative Humidity (%)		Precipitation
	Average Maximum	Average Minimum	Average Monthly (mm)
January	74	52	9.4
February	79	51	9.6
March	85	52	12.5
April	89	56	40.1
May	89	61	61.1
June	87	62	92.3
July	89	62	84.8
August	88	61	72.4
September	87	58	44.3
October	79	54	28.4
November	72	52	25.3
December	72	52	12.8
<b>Year</b>	<b>83</b>	<b>56</b>	<b>492.8</b>

### 2.2.3 Temperature

The long-term temperatures recorded at the Cape Town International Airport were obtained from the South African Weather Service for the period from 1991 to 2020, as given in Table 2-2.

Over the course of a year, temperatures typically vary from 7°C to 27°C and will rarely go below 4°C or above 31°C.

**Table 2-2: Long-term temperature averages for Cape Town**

Month	Temperature (°C)		
	Average Daily Mean	Average Daily Maximum	Average Daily Minimum
January	21.8	27.0	16.6
February	21.9	27.3	16.5
March	20.5	26.0	15.0
April	17.9	23.6	12.2
May	15.4	20.6	10.2
June	13.2	18.2	8.1
July	12.7	17.9	7.4
August	13.0	18.0	7.9
September	14.5	19.6	9.4
October	16.9	22.2	11.5
November	18.6	23.7	13.4
December	20.7	25.8	15.6
<b>Year</b>	<b>17.3</b>	<b>22.5</b>	<b>12.0</b>

## 2.2.4 Atmospheric Stability

Atmospheric stability is frequently categorised into one of six stability classes. These are briefly described in Table 2-3. The atmospheric stability, in combination with the wind speed, is important in determining the extent of a pollutant from a release.

A very stable atmospheric condition, typically at night, would have a low wind speed and produce the greatest endpoint for a dense gas. Conversely, a buoyant gas would have the greatest endpoint distance at a high wind speed.

**Table 2-3: Classification scheme for atmospheric stability**

Stability Class	Stability Classification	Description
A	Very unstable	Calm wind, clear skies, hot daytime conditions.
B	Moderately unstable	Clear skies, daytime conditions.
C	Unstable	Moderate wind, slightly overcast daytime conditions.
D	Neutral	Strong winds or cloudy days and nights.
E	Stable	Moderate wind, slightly overcast night-time conditions.
F	Very stable	Low winds, clear skies, cold night-time conditions.

This risk assessment's calculations are based on six representative weather classes covering the stability conditions of stable, neutral and unstable, as well as low and high wind speeds. In terms of Pasquill classes, the representative conditions are given in Table 2-4.

**Table 2-4: Representative weather classes**

Stability Class	Wind (m/s)
B	3
D	1.5
D	5
D	9
E	5
F	1.5

The allocation of observations into the six weather classes is summarised in Table 2-5, with the representative weather classes given in Figure 2-3.

**Table 2-5: Allocation of observations into six weather classes**

Wind Speed	A	B	B/C	C	C/D	D	E	F
< 2.5 m/s	B 3 m/s			D 1.5 m/s		F 1.5 m/s		
2.5 - 6 m/s				D 5 m/s		E 5 m/s		
> 6 m/s				D 9 m/s				

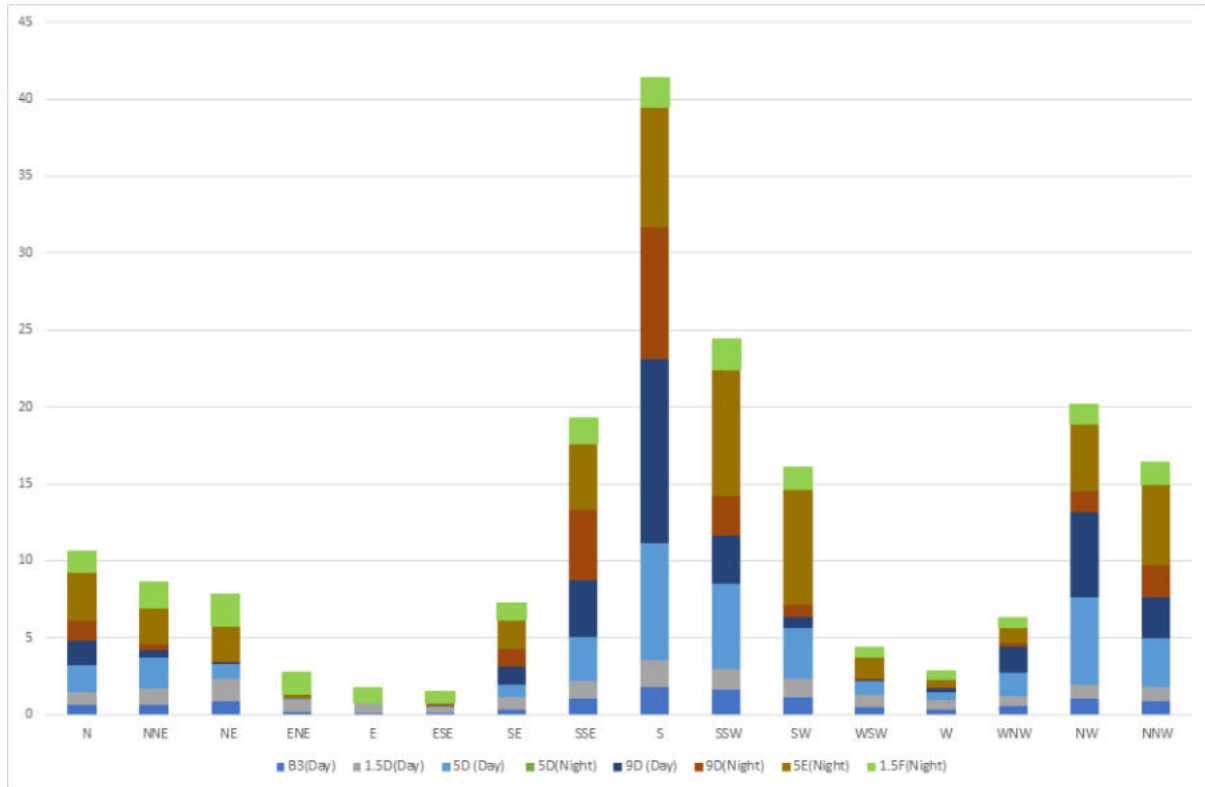

**Figure 2-3: Representative weather classes for Cape Town (2018–2022)**

### 2.2.5 Meteorological Simulation Values

Default meteorological values used in simulations, based on local conditions, are given in Table 2-6.

**Table 2-6: Default meteorological values used in simulations, based on local conditions**

Parameter	Default Value (Day)	Default Value (Night)
Ambient temperature (°C)	22.5	12
Substrate or bund temperature (°C)	17.3	17.3
Water temperature (°C)	17,3	17.3
Air pressure (bar)	1.013	1.013
Humidity (%)	56	83
Fraction of a 24-hour period	0.5	0.5
Mixing height	1	1

1 Calculated as part of the software.



### 3 PROJECT DESCRIPTION

#### 3.1 Site

The proposed CWA facility in Durbanville will consist of a runway, aircraft parking, hanger space, aircraft workshops, a passenger terminal, offices and infrastructure to sustain a mid-sized aircraft terminal. This risk assessment is primarily focused on the storage of hazardous fuels. Figure 3-1 indicates the conceptual layout of the proposed CWA facility with the location of the proposed aircraft fuel storage.

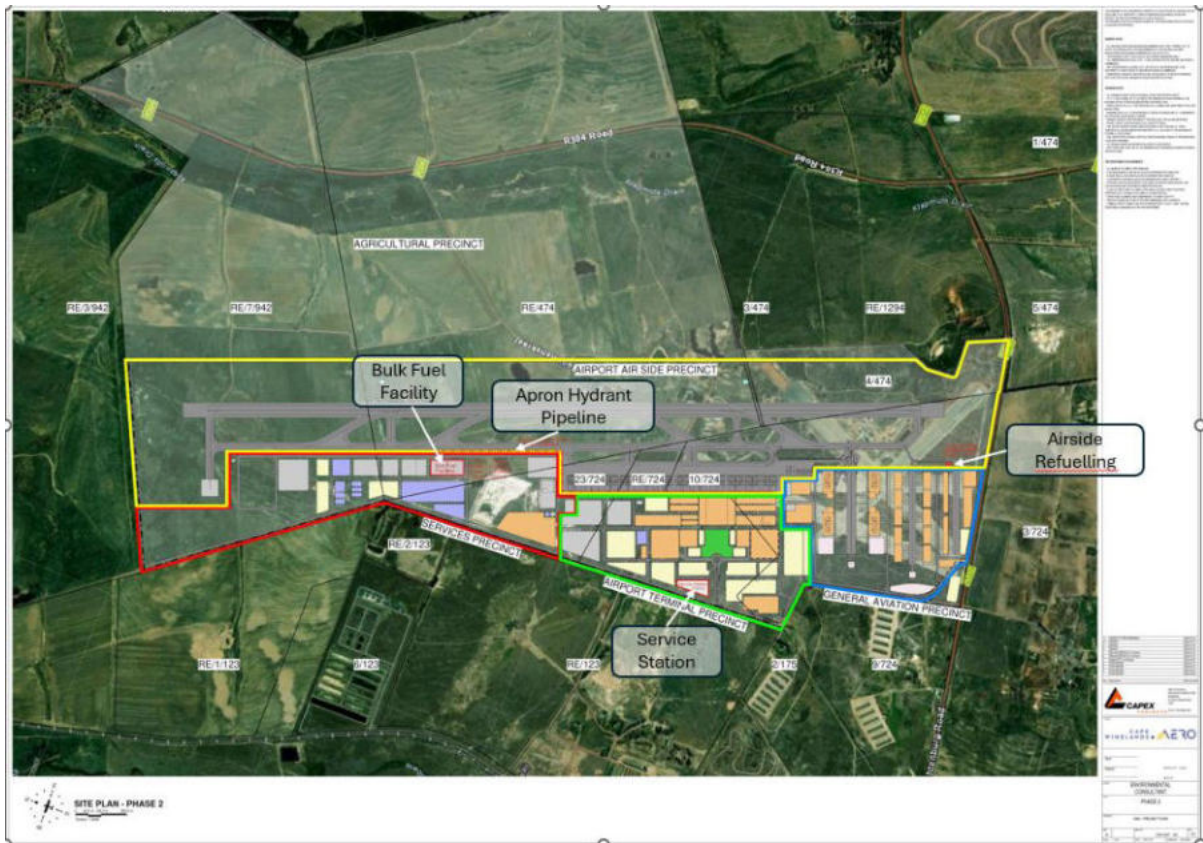

Figure 3-1: Site layout

The project is expected to be done in three phases, depending on the increased passenger and aircraft demand. The three phases of the fuel storage development are indicated in Figure 3-2 and Figure 3-3.

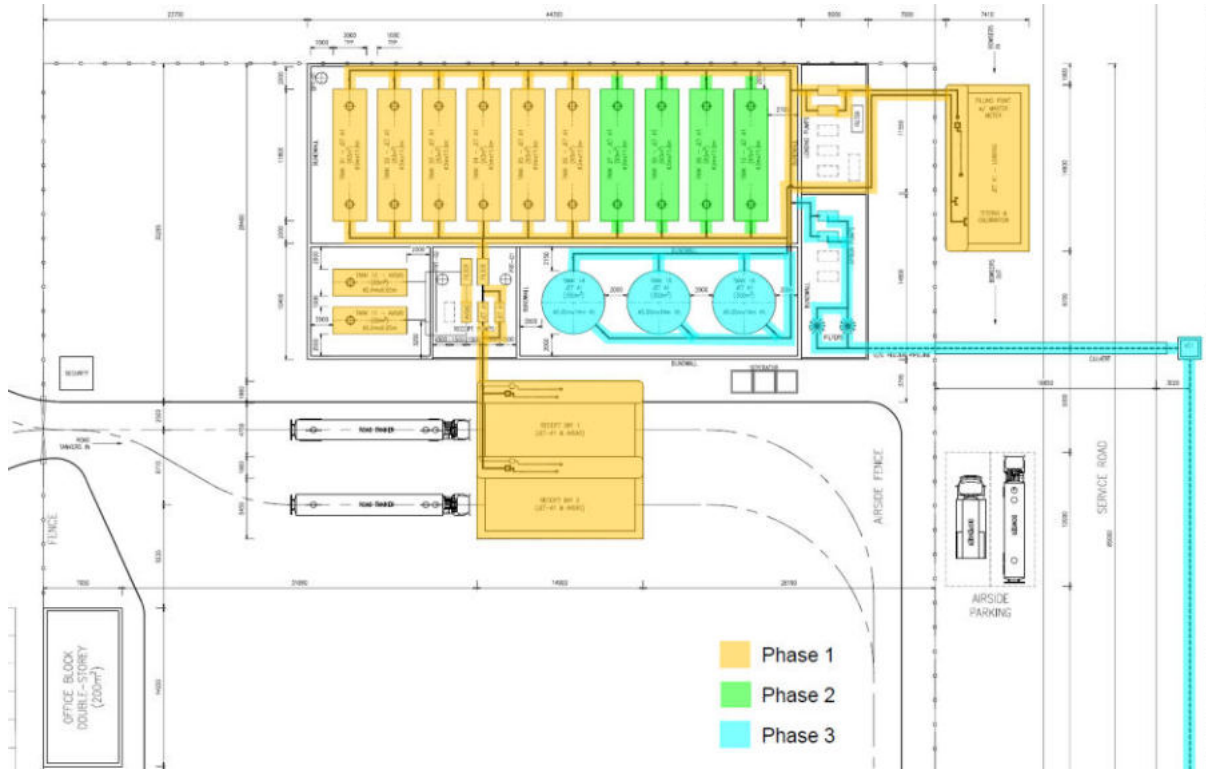

Figure 3-2: Proposed bulk fuel depot per phase

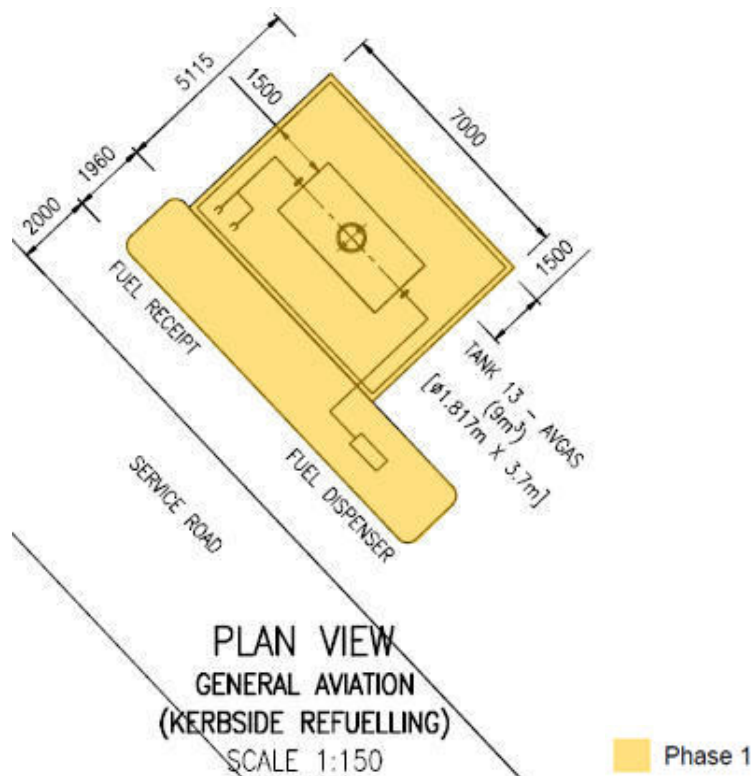

Figure 3-3: Proposed kerbside refuelling for Phase 1

## **3.2 Process Description**

It is anticipated that the proposed CWA facility may expand sometime in the future, including the increase on aviation fuel storage.

### **3.2.1 Road Receipt Facility**

All fuel will be received and offloaded by road tankers. Fuel will be ordered from the Astron Energy refinery in Milnerton, the storage terminals (BP or Engen) in Montague Gardens, or Burgan Cape Terminal at the Cape Town harbour. Deliveries should not take more than one day from when the order is placed.

The following are proposed to be built on site:

- Depot provided with a dedicated road receipt facility with entrance / exit for road tankers;
- Two receipt bays (both left-side offloading), each provided with 1 x receipt point (hoses and API dry-break couplers);
- Three receipt pumps;
- Provision for custody transfer metering;
- Provision to be made with a quick sampling tank for quality control;
- Two horizontal filter vessels (one for Jet A-1 and another for Avgas), each with a limiting capacity of 1 500 ℓ/min.

### **3.2.2 Jet A-1 Storage Tanks (Phase 1 to Phase 3)**

#### **3.2.2.1 Phase 1 (2029): Storage Tanks**

The storage tanks and associated infrastructure is described below:

- Phase 1 consists of 6 x horizontal tanks with a total gross storage capacity of 498 m<sup>3</sup> (sufficient to provide 7 x days buffer stock for the first 5 years of operation).
- Each tank will be provided with Automatic Tank Gauging (ATG) and independent overfilling protection.
- Each tank fitted with floating suction, sufficiently sized for at least 1 500 ℓ/min.
- The horizontal tanks will be provided with one shared Quick Flush Tank (QFTNo1).
- For secondary containment, the horizontal tanks (Jet A-1) all share a common bunded area with concrete floors and walls (the vertical tanks should be provided with their own).

#### **3.2.2.2 Phase 2 (2032): Storage Tanks**

The storage tanks and associated infrastructure is described below:

- Installation of 4 x horizontal tanks with a gross storage capacity of 332 m<sup>3</sup>, to bring the total installed capacity to 830 m<sup>3</sup>. The combined capacity should be sufficient to provide at least 7 x days buffer stock for the next 5 years of operation.

- Each tank will be provided with Automatic Tank Gauging (ATG) and independent overfilling protection.
- Each tank fitted with floating suction, sufficiently sized for at least 1 500 ℓ/min.
- The additional horizontal tanks will be provided with one shared Quick Flush Tank (QFTNo2).
- For secondary containment, the horizontal tanks (Jet A-1) all share a common bunded area with concrete floors and walls (the vertical tanks should be provided with their own).

### **3.2.2.3 Phase 3 (2038): Storage Tanks**

- Install additional 3 x vertical storage tanks, each with a gross capacity of 400 m<sup>3</sup>, to bring the total installed capacity to 1 850 m<sup>3</sup>.
- The combined capacity should be sufficient to provide at least 7 x days buffer stock for the next 20 years of operation.
- The tanks would be of the fixed roof type, constructed to API 650, with concrete foundation.
- Each tank fitted with floating suction, sufficiently sized for at least 3 000 ℓ/min.
- Each tank will be provided with Automatic Tank Gauging (ATG) and independent overfilling protection.
- The three vertical tanks will be provided with one dedicated Quick Flush Tank (QFTNo3).

### **3.2.3 Avgas Facilities**

The depot should also be provided with two double-walled horizontal tanks (Fireguard or similar type) for Avgas, with a total storage capacity of 60 m<sup>3</sup>. The tanks should be provided with pressure-vacuum vents and emergency vent bursting disks. The Avgas tanks will be located within their own bunded area, with concrete floors and walls. Avgas tanks are installed with a slope for water collection. Each tank is connected to a shared quick flush tank (QFTNo4). The Avgas receipt pump and filter (with a limiting capacity of 750 ℓ/min) could be located next to the road receipt facilities, next to the Jet A-1 pumps and filters.

The bulk receipt of Avgas and the filling of the bowser would be at the bulk fuel depot as described above. The same pump and filter will be used to fill bowsers.

### **3.2.4 Loading Area**

#### **3.2.4.1 Bowser Filling and Testing Facility**

For the first 15 years, it should be possible to deliver all fuels to the planes by means of the bowser and the related facilities as described below:

- The depot is provided with a dedicated bowser filling and testing facility with a separate entrance / exit for all bowsers.
- The facility is provided with two loading / filling pumps.

- One horizontal filter vessel (with a limiting capacity of 1 500 ℓ/min).
- The loading pumps is connected to a hydrant pit valve (located on the island).
- A bowser filling and testing facility will be provided with a quick sampling tank (quality control).

#### **3.2.4.2 Apron Pipeline and Hydrant Pits**

From the year 2038 onwards, the fuel related infrastructure should supply between 156 and 219 kℓ/day (of Jet A-1) to about 34 x departing planes. This demand can be met with bowser vehicles; however, a roundtrip could be 20 minutes (travelling to the depot, connecting hoses, starting of the pump, filling the bowser, disconnect hoses, and return to the apron stands, etc.).

The proposed concept design includes the provision of a feeder pipeline (150 NB) to service the apron stands. Allow for a dedicated apron pump and vertical coalescer filters (with a total limiting capacity of 3 000 ℓ/min). The refuelling strategy (browsers only vs apron pipeline and hydrant pit valves) will be confirmed during the Detailed Engineering.

The fuel depot's apron pump and filter facilities are described below (For Phase 3 only):

- Two apron loading pumps.
- Two vertical filter vessels (one on duty / one on standby, each with a capacity of 3 000 ℓ/min).
- Filters provided with flow control valves on discharge to ensure regulated flow and limit linear velocities through filter cartridges.
- Valve chamber (VC1) with actuated expanding plug valves to quickly isolate the feeder pipeline in the event of an emergency (emergency shut-down valve, ESD).
- Valve chambers (VC2, VC3 and VC4) are provided with maintenance isolation valves.
- Allow for 11 x apron stands, each provided with a hydrant pit valve and isolation valve located in the 460 NB bottom-entry hydrant pit boxes (to standard EI 1584).
- Each pit valve to be provided with low-point drains and high-point vents.
- Based on the proposed routing of the feeder pipeline, the total linear length of the 150 NB pipeline is 1 910 m, terminating at VC4.

#### **3.2.4.3 Vehicles on Site**

It is proposed that the airport should be serviced by:

- One 18 000 litre bowser truck (Jet A-1), with a filling rate of approximately 650 ℓ/min.
- One 9 000 litre bowser truck (Jet A-1), with a filling rate of approximately 450 ℓ/min.
- One 4 500 litre bowser truck (Avgas), with a filling rate of approximately 450 ℓ/min.
- One dispenser vehicle (also known as a hydrant servicer), with a filling rate of approximately 1 800 ℓ/min (only if the feeder pipeline and hydrant pits are installed).
- A slops trailer to collect from the pipeline low-points (also, only required if the feeder pipeline and hydrant pits are installed).

### 3.3 Summary of Bulk Materials to be Stored on Site

A summary of bulk materials that can give hazardous effects that are to be stored on site is given below.

#### 3.3.1 Fuel Storage at the end of Phase 1

**Table 3-1: Summary of Jet A-1 to be stored on site at the end of Phase 1**

Tank No.	Type	Diameter (m)	Length (m)	Design (m <sup>3</sup> )	Bunded Area (m <sup>2</sup> )	Bund Volume (m <sup>3</sup> )
01	Horizontal atmospheric tanks with supporting cradles	3.0	11.8	83	Single bunded	Bund height of 1.6 m (Assumed)
02		3.0	11.8	83		
03		3.0	11.8	83		
04		3.0	11.8	83		
05		3.0	11.8	83		
06		3.0	11.8	83		
<b>TOTAL</b>				<b>498</b>	<b>680</b>	<b>1 087</b>
<b>TOTAL (t)</b>				<b>398.4</b>		

**Table 3-2: Summary of Avgas to be stored on site at the end of Phase 1**

Tank No.	Type	Diameter (m)	Length (m)	Design (m <sup>3</sup> )	Bunded Area (m <sup>2</sup> )	Bund Volume (m <sup>3</sup> )
11	Horizontal atmospheric tanks.	2.3	7.45	30	105	169
12		2.3	7.45	30		
13	Double-walled tank (Fireguard or similar type)	1.82	3.70	9	35	56
<b>TOTAL</b>				<b>69</b>		
<b>TOTAL (t)</b>				<b>48.3</b>		

### 3.3.2 Fuel Storage at the end of Phase 2

**Table 3-3: Summary of Jet A-1 to be stored on site at the end of Phase 2**

Tank No.	Type	Diameter (m)	Length (m)	Design (m <sup>3</sup> )	Bunded Area (m <sup>2</sup> )	Bund Volume (m <sup>3</sup> )
01	Horizontal atmospheric tanks with supporting cradles	3.0	11.8	83	Single bunded	Bund height of 1.6 m (Assumed)
02		3.0	11.8	83		
03		3.0	11.8	83		
04		3.0	11.8	83		
05		3.0	11.8	83		
06		3.0	11.8	83		
07		3.0	11.8	83		
08		3.0	11.8	83		
09		3.0	11.8	83		
10		3.0	11.8	83		
				<b>TOTAL</b>	<b>830</b>	<b>680</b>
				<b>TOTAL (t)</b>	<b>664</b>	<b>1 087</b>

**Table 3-4: Summary of Avgas to be stored on site at the end of Phase 2**

Tank No.	Type	Diameter (m)	Length (m)	Design (m <sup>3</sup> )	Bunded Area (m <sup>2</sup> )	Bund Volume (m <sup>3</sup> )
11	Horizontal atmospheric tanks.	2.3	7.45	30	105	169
12		2.3	7.45	30		
13	Double-walled tank (Fireguard or similar type)	1.82	3.70	9	35	56
				<b>TOTAL</b>	<b>69</b>	
				<b>TOTAL (t)</b>	<b>48.3</b>	

### 3.3.3 Fuel Storage at the end of Phase 3

**Table 3-5: Summary of Jet A-1 to be stored on site at the end of Phase 3**

Tank No.	Type	Diameter (m)	Length (m)	Design (m <sup>3</sup> )	Bunded Area (m <sup>2</sup> )	Bund Volume (m <sup>3</sup> )
01	Horizontal atmospheric tanks with supporting cradles	3.0	11.8	83	680	1 087
02		3.0	11.8	83		
03		3.0	11.8	83		
04		3.0	11.8	83		
05		3.0	11.8	83		
06		3.0	11.8	83		
07		3.0	11.8	83		
08		3.0	11.8	83		
09		3.0	11.8	83		
10		3.0	11.8	83		
14	Vertical storage tank with concrete foundation	5.65	14.0	400		
15		5.65	14.0	400		
16		5.65	14.0	400		
<b>TOTAL</b>				<b>2 030</b>		
<b>TOTAL (t)</b>				<b>1 864</b>		

**Table 3-6: Summary of Avgas to be stored on site at the end of Phase 3**

Tank No.	Type	Diameter (m)	Length (m)	Design (m <sup>3</sup> )	Bunded Area (m <sup>2</sup> )	Bund Volume (m <sup>3</sup> )
11	Horizontal atmospheric tanks.	2.3	7.45	30	105	169
12		2.3	7.45	30		
13	Double-walled tank (Fireguard or similar)	1.82	3.70	9	35	56
<b>TOTAL</b>				<b>69</b>		
<b>TOTAL (t)</b>				<b>48.3</b>		



### 3.4 Establishment Tier

The MHI Regulations (2022), under Chapter 1 and Chapter 2, defines the establishment tier.

The summary for the Jet A-1 and Avgas storage and the resultant tier classification, is given in Table 3-7.

**Table 3-7: Summary of the hazard tier related from the inventory stored**

Named Substances	UN Number	Quantities in tonnes (t)		
		Column 1 Low Hazard	Column 2 Medium Hazard	Column 3 High Hazard
Petroleum products: Gasolines, Naphtha's, Kerosene's (including Jet fuels), Gas oils (including Diesel fuels, Home heating oils and Gas oil blending streams).	Gas (1075) Crude (1275)	250	2 500	25 000

The expected MHI hazard tier for each phase of the fuel storage projects, is given in Table 3-8.

**Table 3-8: Expected establishment hazardous tier per project phase**

Phase	Avgas Inventory (t)	Jet A-1 Inventory (t)	Total (t)	Hazard Tier
1	394.2	48.3	442.5	Low Hazard
2	664	48.3	712.3	Low Hazard
3	1 864	38.3	1 902.3	Low Hazard

## 4 HAZARD IDENTIFICATION

The first step in any risk assessment is to identify all hazards. The merit of including a hazard for further investigation is then determined by how significant it is, normally by using a cut-off or threshold value.

Once a hazard has been identified, it is necessary to assess it in terms of the risk it presents to the employees and the neighbouring community. In principle, both the probability and consequence should be considered, but there are occasions where, if either the probability or the consequence can be shown to be sufficiently low or sufficiently high, decisions can be made based on just one factor.

During the hazard identification component of the report, the following considerations are taken into account:

- Chemical identities;
- Location of on-site installations that use, produce, process, transport or store hazardous components;
- Type and design of containers, vessels or pipelines;
- Quantity of material that could be involved in an airborne release;
- Nature of the hazard most likely to accompany hazardous materials spills or releases, e.g., airborne toxic vapours or mists, fires or explosions, large quantities to be stored and certain handling conditions of processed components.

The evaluation methodology assumes that the facility will perform as designed in absence of unintended events, such as component and material failures of equipment, human errors, external events and process unknowns.

### 4.1 Notifiable Substances

The General Machinery Regulation 8 and its Schedule A on notifiable substances requires any employer who has a substance equal to or exceeding the quantity listed in the regulation to notify the divisional director. A site is classified as a Major Hazard Installation if it contains one or more notifiable substances or if the off-site risk is sufficiently high. The latter can only be determined from a quantitative risk assessment.

No material to be stored on site is listed as notifiable.

## 4.2 Substance Hazards

All components on site were assessed for potential hazards according to the criteria discussed in this section.

### 4.2.1 Chemical Properties

A short description of bulk hazardous components to be stored on, produced at or delivered to site is given in the following subsections. The material safety data sheets (MSDSs) of the respective materials are attached in Appendix E.

#### 4.2.1.1 Jet A-1 / Kerosene (UN No. 1863)

Jet A-1 / Kerosene has the same chemical and physical properties as paraffin, but requires stricter controls as aircraft fuel.

Kerosene is a clear colourless to light amber liquid with a petroleum odour and consists of a distillate fraction refined from crude petroleum. Therefore, the composition and physical properties may vary. The flashpoint is approximately 38°C, and it is considered flammable. It has a low toxicity to humans.

It is relatively stable under normal storage conditions. However, saturated aliphatic hydrocarbons contained in kerosene may be incompatible with strong oxidising agents like nitric acid.

It can be absorbed into the body by inhalation of its vapour, through the skin and by ingestion.

Short-term exposure could irritate the skin and respiratory tract. Swallowing the liquid may cause aspiration into the lungs, with risk of chemical pneumonitis.

Repeated or prolonged contact with skin may cause dermatitis, as the liquid defats the skin.

It may cause an environmental problem, particularly in water, if spilt.

#### 4.2.1.2 Avgas (UN No. 1203)

Avgas is aviation fuel that consisting mostly of gasoline (petrol). It is a hydrocarbon mixture with variable composition and with a boiling point range of between 35°C and 170°C. It is a pale-yellow liquid with a strong petroleum odour. Due to the flash point of minus 40°C, this material is considered highly flammable and will readily ignite under suitable conditions. The vapours of petrol are heavier than air and may travel some distance to an ignition source.

Avgas may contain up to 5% volume of benzene, a known animal carcinogen. It may also contain ethers and alcohols as oxygenates to a maximum concentration of 2%. It may also contain small quantities of lead to enhance performance.

Petrol is stable under normal conditions. It will react with strong oxidising agents and nitrate compounds, which reaction may cause fires and explosions.

Although Avgas is of a low to moderate oral toxicity to adults, ingestion of small quantities may prove to be dangerous or fatal to small children.

Contact with vapours may result in slight irritation to the nose, eyes and skin. Vapours may cause headache, dizziness, loss of consciousness or suffocation, as well as lung irritation with coughing, gagging, dyspnoea, substernal distress and rapidly developing pulmonary oedema.

If swallowed, petrol may cause nausea or vomiting, swelling of the abdomen, headache, CNS depression, coma and death.

The long-term effects of Avgas exposure have not been determined. However, it may affect lungs and may cause the skin to dry out and become cracked.

Avgas floats on water and can result in environmental hazards with large spills into waterways. It is harmful in high concentrations to aquatic life.

#### 4.2.2 Corrosive Liquids

Corrosive liquids considered under this subsection are those components that have a low or high pH and that may cause burns if they come into contact with people or may attack and cause failure of equipment.

No bulk materials to be stored on, produced at or delivered to site are considered extremely corrosive.

#### 4.2.3 Reactive Components

Reactive components are components that when mixed or exposed to one another react in a way that may cause a fire, explosion or release a toxic component.

All substances to be stored on, produced at or delivered to site are considered thermally stable in atmospheric conditions. The reaction with air is covered under the subsection dealing with ignition probabilities.

#### 4.2.4 Flammable and Combustible Components

Flammable and combustible components are those that can ignite and give a number of hazardous effects, depending on the nature of the component and conditions. These effects may include pool fires, jet fires and flash fires, as well as explosions and fireballs.

The flammable and combustible substances to be stored on, produced at or delivered to site are listed in Table 4-1. These substances have been analysed for fire and explosion risks.

**Table 4-1: Flammable and combustible substances to be stored on, produced at or delivered to site**

Component	Flashpoint (°C)	Boiling Point (°C)	LFL (vol. %)	UFL (vol. %)
Jet A-1	> 37	> 150	0.7	5
Avgas	-40	25 - 170	1%	Not available

### 4.3 Physical Properties

For this study, Avgas and Jet A-1 were modelled as components given in Table 4-2. The physical properties used in the simulations were based on the DIPPR<sup>1</sup> data base.

**Table 4-2: Representative components**

Component	Modelled as
Jet A-1	n-Nonane
Avgas	2% mol Toluene 9% mol o-Xylene 2% mol n-Propylbenzene 2% mol n-Nonane 4% mol n-Octane 14% mol Cyclohexane 9% mol Cyclopentane 9% mol n-Hexane 1% mol n-Decane 14% mol Cyclopentane 22% mol n-Pentane

<sup>1</sup> Design Institute for Physical Properties.

## 5 PHYSICAL AND CONSEQUENCE MODELLING

In order to establish which impacts, follow an accident, it is first necessary to estimate the physical process of the spill (i.e., rate and size), spreading of the spill, evaporation from the spill, subsequent atmospheric dispersion of the airborne cloud and, in the case of an ignition, the burning rate and resulting thermal radiation from a fire and the overpressures from an explosion.

The second step is then to estimate the consequences of a release on humans, fauna, flora and structures in terms of the significance and extent of the impact in the event of a release. The consequences could be due to toxic or asphyxiant vapours, thermal radiation or explosion overpressures. They may be described in various formats.

The simplest methodology would show a comparison of predicted concentrations, thermal radiation or overpressures to short-term guideline values.

In a different but more realistic fashion, the consequences may be determined by using a dose-response analysis. Dose-response analysis aims to relate the intensity of the phenomenon that constitutes a hazard to the degree of injury or damage that it can cause. Probit analysis is possibly the method mostly used to estimate the probability of death, hospitalisation or structural damage. The probit is a lognormal distribution and represents a measure of the percentage of the vulnerable resource that sustains injury or damage. The probability of injury or death (i.e., the risk level) is in turn estimated from this probit (risk characterisation).

Consequence modelling gives an indication of the extent of the impact for selected events and is primarily used for emergency planning. A consequence that would not cause irreversible injuries would be considered insignificant, and no further analysis would be required. The effects from major incidents are summarised in the following subsections.

## 5.1 Multiple Consequence Scenarios

Guidelines for the selection of scenarios is given in RIVM (2009) and CPR 18E (Purple Book; 1999). A particular scenario may produce more than one major consequence. In such cases, consequences are evaluated separately and assigned failure frequencies in the risk analysis. Some of these phenomena are described in the subsections that follow.

### 5.1.1 Continuous Release of a Flammable Liquid

The continuous loss of containment of a flammable liquid could result in the consequences given in the event tree of Figure 5-1. Probability of the events occurring is dependent on a number of factors and is determined accordingly. All the scenarios shown in the figure are determined separately and reported in relevant subsections of the report.

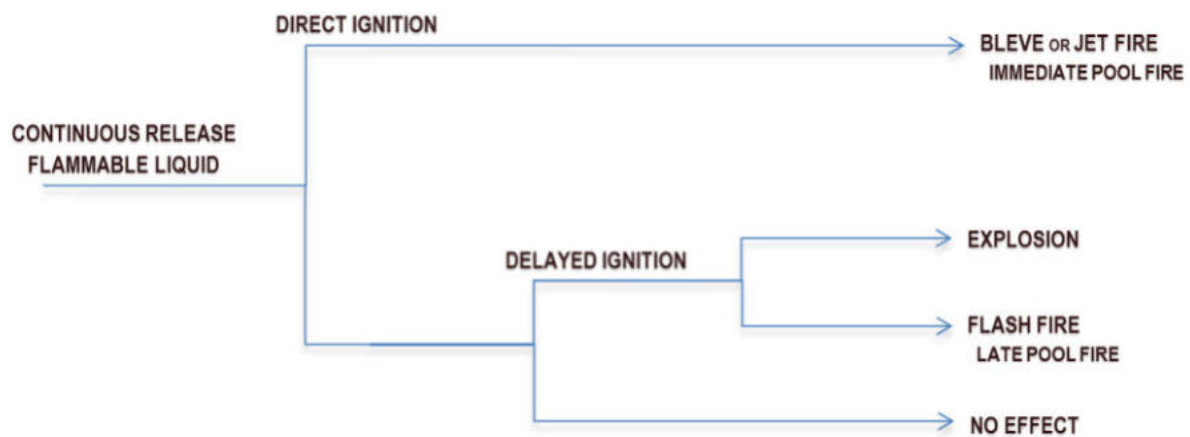

**Figure 5-1: Event tree for a continuous release of a flammable liquid**

## 5.2 Fires

Combustible and flammable components within their flammable limits may ignite and burn if exposed to an ignition source of sufficient energy. On process plants, releases with ignition normally occur as a result of a leakage or spillage. Depending on the physical properties of the component and the operating parameters, combustion may take on a number of forms, such as pool fires, jet fires, flash fires and so forth.

### 5.2.1 Thermal Radiation

The effect of thermal radiation is very dependent on the type of fire and the duration of exposure. Certain codes, such as the American Petroleum Institute API 520 and API 2000 codes, suggest values for the maximum heat absorbed by vessels to facilitate adequate relief designs in order to prevent the failure of the vessel. Other codes, such as API 510 and the British Standards BS 5980 code, give guidelines for the maximum thermal radiation intensity and act as a guide to equipment layout, as shown in Table 5-1.

The effect of thermal radiation on human health has been widely studied, relating injuries to the time and intensity of exposure.

**Table 5-1: Thermal radiation guidelines (BS 5980 of 1990)**

Thermal Radiation Intensity (kW/m <sup>2</sup> )	Limit
1.5	Will cause no discomfort for long exposure
2.1	Sufficient to cause pain if unable to reach cover within 40 seconds
4.5	Sufficient to cause pain if unable to reach cover within 20 seconds
12.5	Minimum energy required for piloted ignition of wood and melting of plastic tubing
25	Minimum energy required to ignite wood at indefinitely long exposures
37.5	Sufficient to cause serious damage to process equipment

For pool fires, jet fires and flash fires CPR 18E (Purple Book; 1999) suggests that the following thermal radiation levels should be reported:

- 4 kW/m<sup>2</sup>, the level that glass can withstand, preventing the fire entering a building, and that should be used for emergency planning;
- 10 kW/m<sup>2</sup>, the level that represents the 1% fatality for 20 seconds of unprotected exposure and at which plastic and wood may start to burn, transferring the fire to other areas;
- 37.5 kW/m<sup>2</sup>, spontaneous ignition of hair and clothing occurs, with an assumed 100% fatality, and at which initial damage to steel may occur.



### 5.2.2 Bund and Pool Fires

Pool fires, either tank or bund fires, consist of large volumes of a flammable liquid component burning in an open space at atmospheric pressure.

The flammable component will be consumed at the burning rate, depending on factors including prevailing winds. During combustion, heat will be released in the form of thermal radiation. Temperatures close to the flame centre will be high, but will reduce rapidly to tolerable temperatures over a relatively short distance. Any building or persons close to the fire or within the intolerable zone will experience burn damage with severity depending on the distance from the fire and time exposed to the heat of the fire.

In the event of a pool fire, the flames will tilt according to the wind speed and direction. The flame length and tilt angle will affect the distance of the thermal radiation generated.

Flammable and combustible materials to be stored on site include Jet A-1 and Avgas.

A loss of containment could occur at the offloading tanker or at the pump and its lines. On loss of containment, a pool will form and the material will evaporate at a rate determined by the surface area of the pool, the temperature of the pool and the wind conditions. In the event of an ignition, the evaporation rate would be replaced with the burning rate.

Instantaneous failure of a storage tank can result if a proportion of the component overflows the top of the bund, referred to as 'overtopping'. For the scenario of an instantaneous release, the amount of overtopping is taken to be an average of 33%. This is translated to the risk assessment by increasing the surface area of the bund by 50% (RIVM 2009).

A tank release, such as an overfilling or piping failure, would not result in overtopping, and even in the worst case, would be contained within the bunded area.

The 1% fatality (represented by the  $10\text{kW}/\text{m}^2$ ) for the various pool fire scenarios at the tank farm is shown in Figure 5-2, at the end of Phase 2. The isopleths represent a worst-case scenario from a strong wind from all cardinal directions. The pool fire is dominated by the pool fire from a catastrophic failure of the horizontal Jet A-1 tanks.

Pool fires could extend beyond the tank farm boundaries, but would not extend into areas occupied by the aircrafts or the general public.

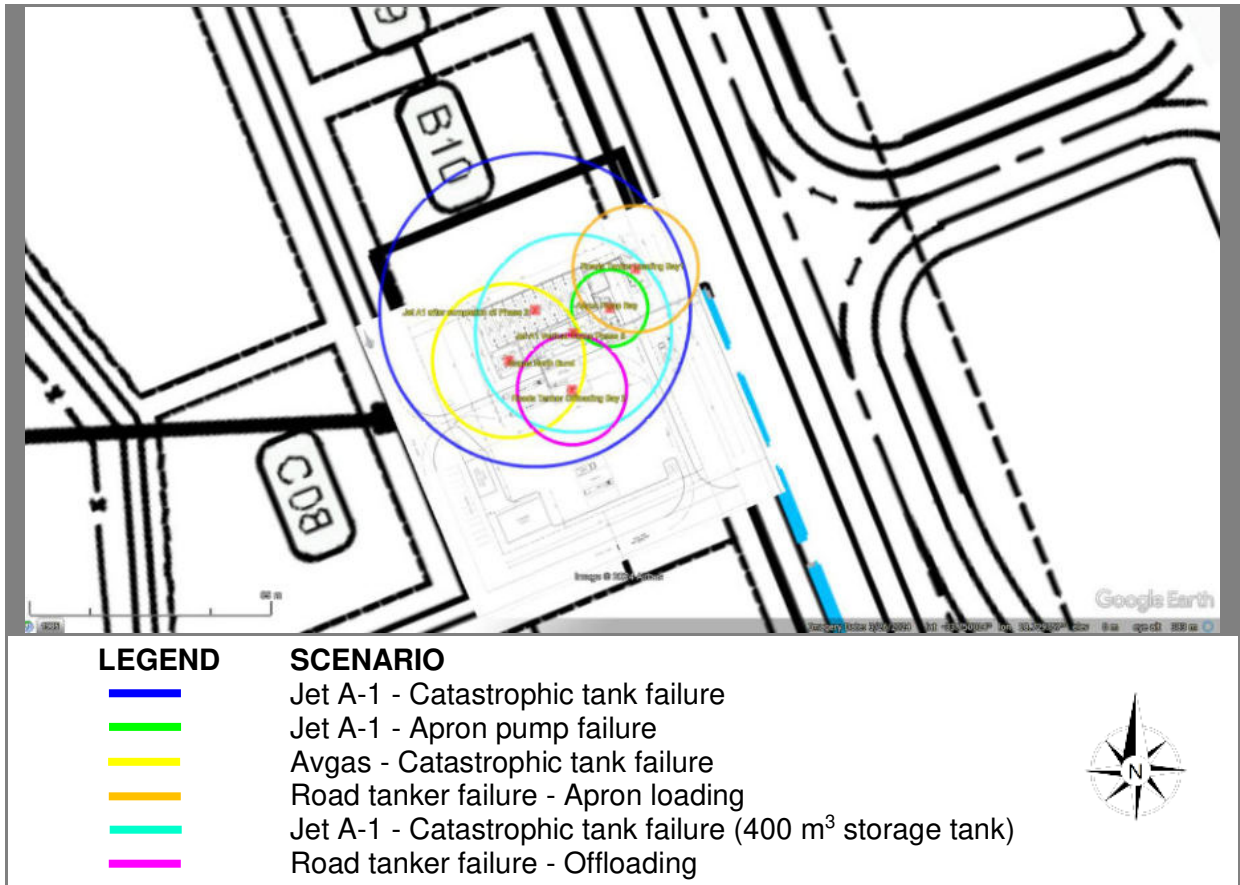

**Figure 5-2: The 1% fatality from various pool fire scenarios at the fuel tank farm**

The 1% fatality (represented by the 10kW/m<sup>2</sup>) maximum effect of a pool fire from a loss of containment at the kerbside refuelling, is shown in Figure 5-3. In this instance, the impacts will not extend to the runway, public or any aircraft.

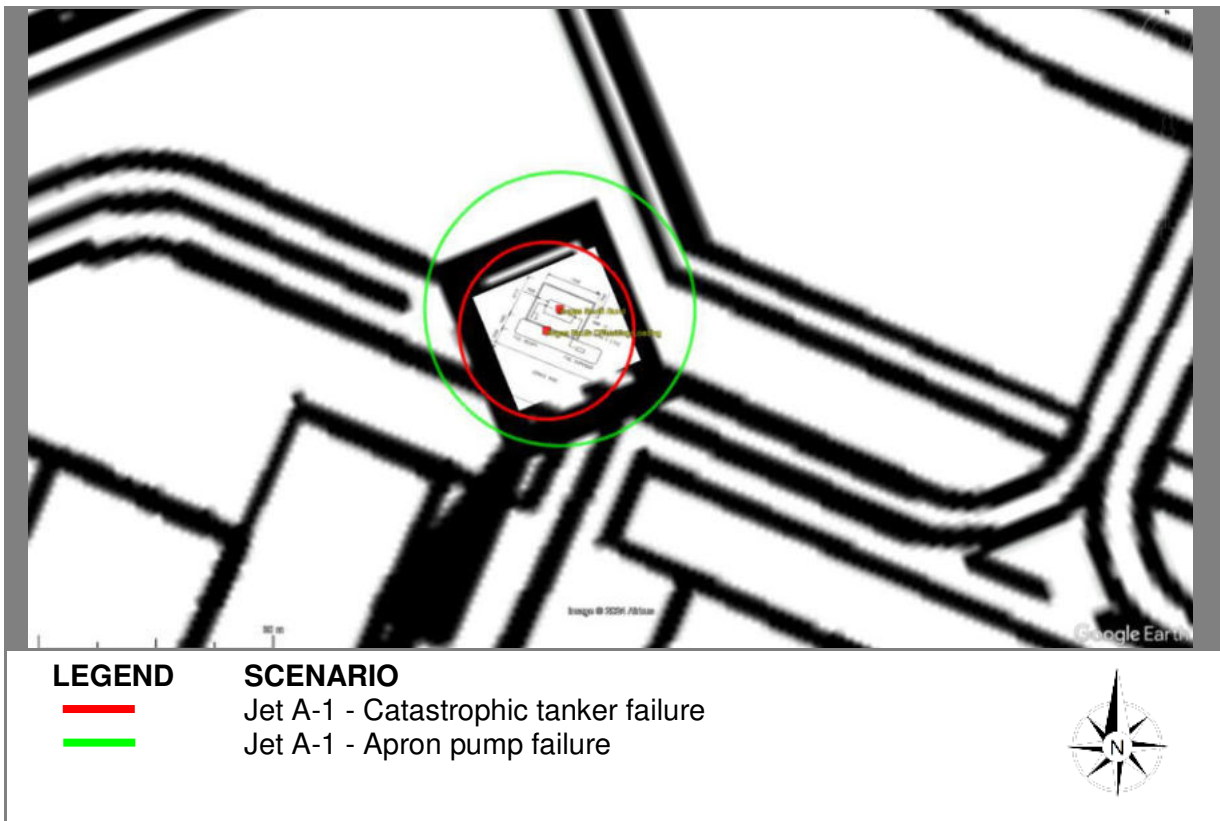
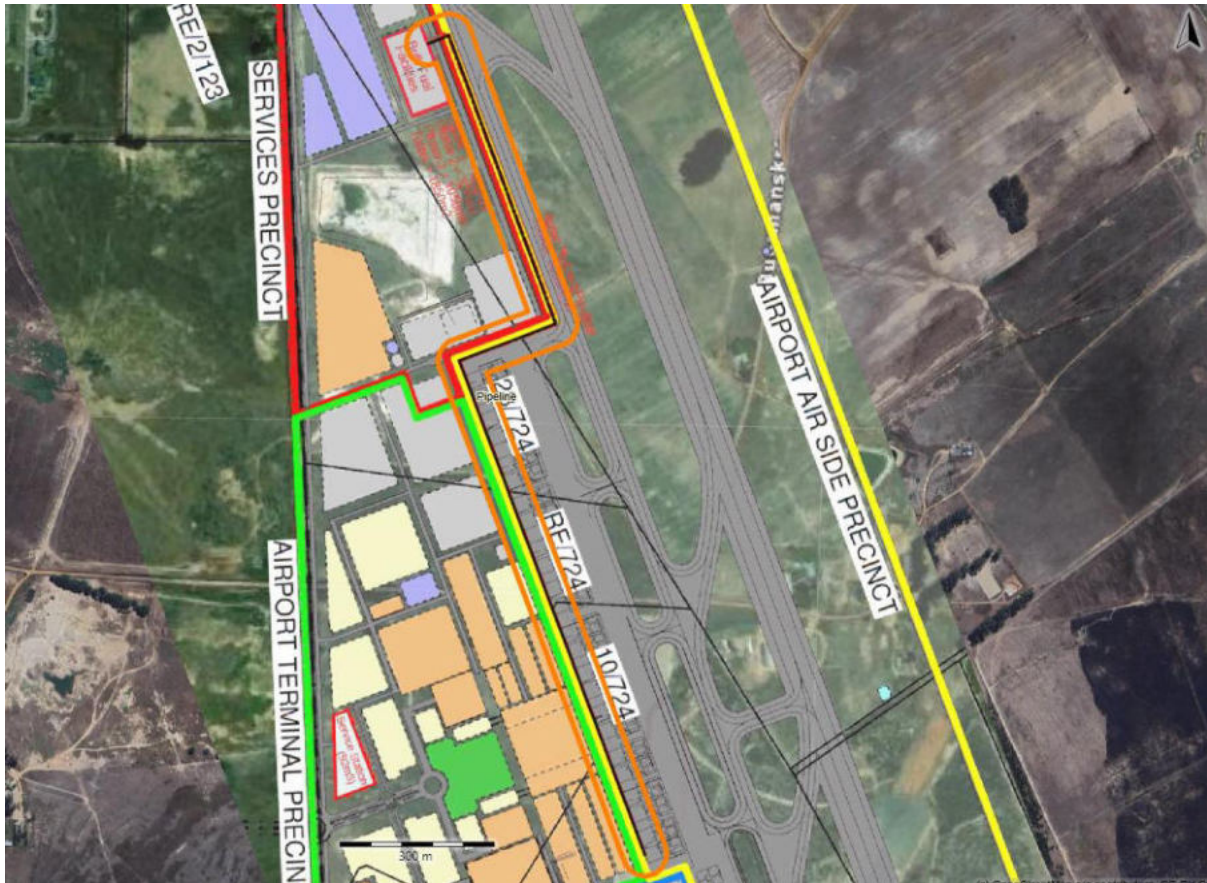

**Figure 5-3: The 1% fatality from various pool fire scenarios at the kerbside refuelling**

### 5.3 Apron Pipeline

The apron pipeline is expected to be constructed during Phase 3. The pipeline would be located in a chamber following the route, as shown in Figure 5-4. Thus, a loss of containment will firstly fill the chamber and then overflow onto the apron. For this study, the maximum area from a pool formed from a loss of containment was limited to 300 m<sup>2</sup>.

The 1% fatality from the apron pipeline, is shown in Figure 5-4. The extent to the 1% fatality could reach 41 m from the pipeline.

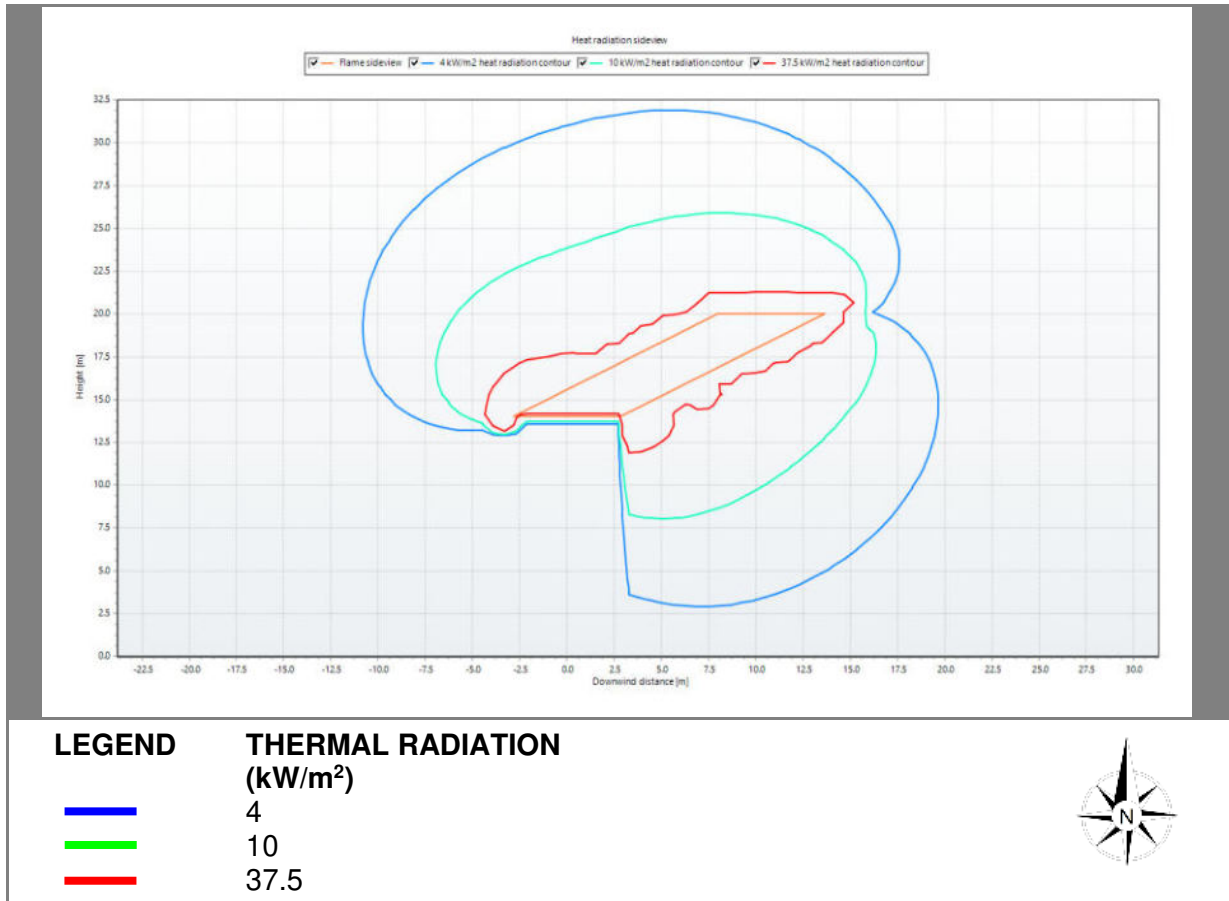

**Figure 5-4: The 1% fatality from a Jet A-1 pool fire from a loss of containment of the Jet A-1 apron pipeline**

### 5.3.1 Tank-Top Fires

A tank-top fire occurs within the tank, and thus the pool fire is limited to the area of the tank. A tank-top fire could escalate to a bund fire should the tank fail, releasing flammable or combustible material into the bund.

A vertical 400 m<sup>3</sup> Jet A-1 fuel tank to be installed during Phase 3 of the project, could experience tank top fires. The maximum side view effect of a tank-top fire in the storage area, is shown in Figure 5-5. No impacts would be expected at ground level.



**Figure 5-5: Side view of the thermal radiation from large Jet A-1 tank-top fires in the storage area**

### 5.3.2 Jet Fires

Jet fires occur when a flammable component is released with a high exit velocity ignites.

In process industries, this may be due to the design (such as flares) or due to accidental releases. Ejection of a flammable component from a vessel, pipe or pipe flange may give rise to a jet fire and in some instances, the jet flame could have substantial 'reach'.

Depending on the wind speed, the flame may tilt and impinge on other pipelines, equipment or structures. The thermal radiation from these fires may cause injury to people or damage equipment some distance away from the source of the flame.

No jet fires were predicted from the simulations.

### 5.3.3 Flash Fires

A loss of containment of a flammable component may mix with air, forming a flammable mixture. The flammable cloud would be defined by the lower flammable limit (LFL) and the upper flammable limit (UFL). The extent of the flammable cloud would depend on the quantity of the released and mixed component, physical properties of the released component, wind speed and weather stability.

An ignition within a flammable cloud can result in an explosion if the front is propagated by pressure. If the front is propagated by heat, then the fire moves across the flammable cloud at the flame velocity and is called a flash fire. Flash fires are characterised by low overpressure, and injuries are caused by thermal radiation. The effects of overpressure due to an exploding cloud are covered in the subsection dealing with vapour cloud explosions (VCEs).

A flash fire would extend to the lower flammable limit; however, due to the formation of pockets, it could extend beyond this limit to the point defined as the  $\frac{1}{2}$  LFL. It is assumed that people within the flash fire would experience lethal injuries, while people outside of the flash fire would remain unharmed. The  $\frac{1}{2}$  LFL is used for emergency planning to evacuate people to a safe distance in the event of a release.

Flash fires could result from a loss of a containment of Avgas with subsequent ignition. From the simulations, the greatest extent of a flash fire would be less than 7 m from the center of the pool and is thus not show.

## 5.4 Explosions

The concentration of a flammable component would decrease from the point of release to below the lower explosive limits (LEL), at which concentration the component can no longer ignite. The sudden detonation of an explosive mass would cause overpressures that could result in injury or damage to property.

Such an explosion may give rise to any of the following effects:

- Blast damage;
- Thermal damage;
- Missile damage;
- Ground tremors;
- Crater formation;
- Personal injury.

Obviously, the nature of these effects depends on the pressure waves and the proximity to the actual explosion. Of concern in this investigation are the 'far distance effects', such as limited structural damage and the breakage of windows, rather than crater formations.

Table 5-2 and Table 5-3 give a more detailed summary of the damage produced by an explosion due to various overpressures.

CPR 18E (Purple Book; 1999) suggests the following overpressures should be determined:

- 0.03 bar overpressure, corresponding to the critical overpressure causing windows to break;
- 0.1 bar overpressure, corresponding to 10% of the houses being severely damaged and a probability of death indoors equal to 0.025:
  - No lethal effects are expected below the 0.1 bar overpressure on unprotected people in the open;
- 0.3 bar overpressure, corresponding to structures being severely damaged and 100% fatality for unprotected people in the open;
- 0.7 bar overpressure, corresponding to an almost entire destruction of buildings.



**Table 5-2: Summary of consequences of blast overpressure (Clancey 1972)**

Pressure (Gauge)		Damage
Psi	kPa	
0.02	0.138	Annoying noise (137 dB), if of low frequency (10 – 15 Hz)
0.03	0.207	Occasional breaking of large glass windows already under strain
0.04	0.276	Loud noise (143 dB); sonic boom glass failure
0.1	0.69	Breakage of small under strain windows
0.15	1.035	Typical pressure for glass failure
0.3	2.07	'Safe distance' (probability 0.95; no serious damage beyond this value); missile limit; some damage to house ceilings; 10% window glass broken
0.4	2.76	Limited minor structural damage
0.5–1.0	3.45–6.9	Large and small windows usually shattered; occasional damage to window frames
0.7	4.83	Minor damage to house structures
1.0	6.9	Partial demolition of houses, made uninhabitable
1.0–2.0	6.9–13.8	Corrugated asbestos shattered; corrugated steel or aluminium panels, fastenings fail, followed by buckling; wood panels (standard housing) fastenings fail, panels blown in
1.3	8.97	Steel frame of clad building slightly distorted
2.0	13.8	Partial collapsing of walls and roofs of houses
2.0–3.0	13.8–20.7	Concrete or cinderblock walls (not reinforced) shattered
2.3	15.87	Lower limit of serious structural damage
2.5	17.25	50% destruction of brickwork of house
3.0	20.7	Heavy machines (1.4 t) in industrial building suffered little damage; steel frame building distorted and pulled away from foundations
3.0–4.0	20.7–27.6	Frameless, self-framing steel panel building demolished
4.0	27.6	Cladding of light industrial buildings demolished
5.0	34.5	Wooden utilities poles (telegraph, etc.) snapped; tall hydraulic press (18 t) in building slightly damaged
5.0–7.0	34.5–48.3	Nearly complete destruction of houses
7.0	48.3	Loaded train wagons overturned
7.0–8.0	48.3–55.2	Brick panels (20 cm – 30 cm) not reinforced fail by shearing or flexure
9.0	62.1	Loaded train boxcars completely demolished
10.0	69.0	Probable total destruction of buildings; heavy (3 t) machine tools moved and badly damaged; very heavy (12 000 lb. / 5 443 kg) machine tools survived
300	2070	Limit of crater lip



**Table 5-3: Damage caused by overpressure effects of an explosion (Stephens 1970)**

Equipment	Overpressure (psi)																									
	0.5	1	1.5	2	2.5	3	3.5	4	4.5	5	5.5	6	6.5	7	7.5	8	8.5	9	9.5	10	12	14	16	18	20	
Control house steel roof	A	C	V				N																			
Control house concrete roof	A	E	P	D			N																			
Cooling tower	B			F			O																			
Tank: cone roof		D				K								U												
Instrument cubicle			A			LM							T													
Fire heater				G	I					T																
Reactor: chemical				A				I				P							T							
Filter				H						F									V			T				
Regenerator						I				IP																
Tank: floating roof						K								U												D
Reactor: cracking								I							I							T				
Pine supports							P						SO													
Utilities: gas meter										Q																
Utilities: electric transformer										H					I							T				
Electric motor											H									I						V
Blower											Q															
Fractionation column												R			T											
Pressure vessel horizontal													PI									T				
Utilities: gas regulator													I									MQ				
Extraction column														I								V	T			
Steam turbine																I							M	S		V
Heat exchanger															I							T				
Tank sphere																I								I	T	
Pressure vessel vertical																								I	T	
Pump																								I		Y

- A Windows and gauges break
- B Louvers fall at 0.3–0.5 psi
- C Switchgear is damaged from roof collapse
- D Roof collapses
- E Instruments are damaged
- F Inner parts are damaged
- G Bracket cracks
- H Debris-missile damage occurs
- I Unit moves and pipes break
- J Bracing fails
- K Unit uplifts (half filled)
- L Power lines are severed
- M Controls are damaged
- N Block wall fails
- O Frame collapses
- P Frame deforms
- Q Case is damaged
- R Frame cracks
- S Piping breaks
- T Unit overturns or is destroyed
- U Unit uplifts (0.9 filled)
- V Unit moves on foundations

#### **5.4.1 Vapour Cloud Explosions (VCEs)**

The release of a flammable component into the atmosphere could result in formation of a flash fire, as described in the subsection on flash fires, or a vapour cloud explosion (VCE). In the case of a VCE, an ignited vapour cloud between the higher explosive limits (HEL) and the lower explosive limit (LEL), could form a fireball with overpressures that could result in injury or damage to property.

No VCEs were predicted from the simulations.

### 5.4.2 Fixed-Roof Tank Explosions

A confined gas explosion occurs when the exploding flammable mixture is restricted from expanding by physical barriers such as walls, equipment or other obstacles.

A fixed-roof tank explosion is a confined gas explosion within a tank. The explosive mass is calculated as the volume of the tank at its lower flammable limit (LFL). It should be noted that an explosion can only occur if a flammable atmosphere can be formed. For this study, only flammable components with flashpoints lower than 38°C were considered.

The blast pressures from a single Avgas 30 m<sup>3</sup> storage vessel, are shown in Figure 5-6.

The 1% fatality will not extend beyond the site boundary and thus would not impact the general public at the airport.

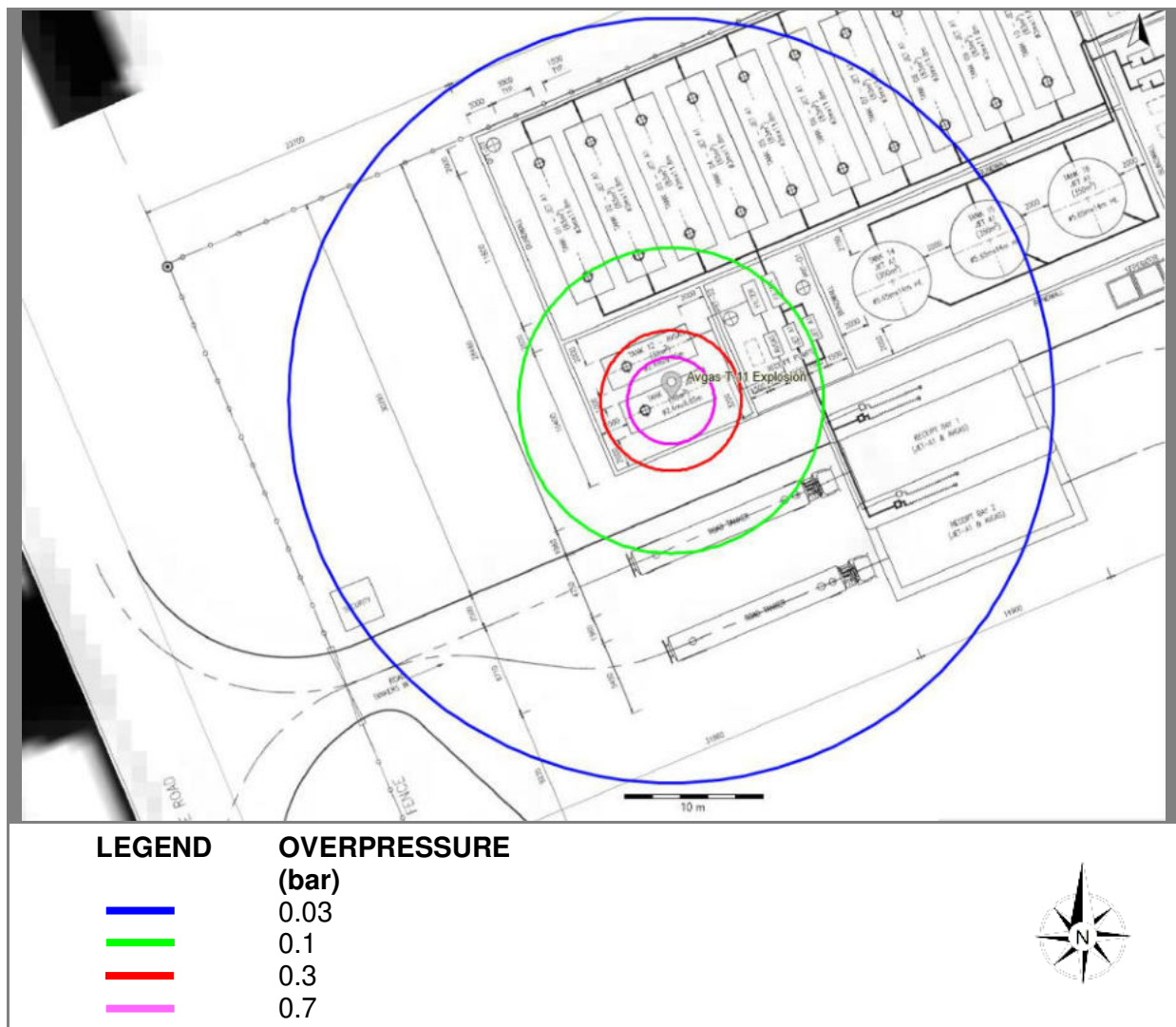

**Figure 5-6: Blast overpressure from a single fixed-roof tank explosion in the Avgas storage area**

### **5.4.3 Boiling Liquid Expanding Vapour Explosions (BLEVEs)**

A boiling liquid expanding vapour explosion (BLEVE) can occur when a flame impinges on a pressure cylinder, particularly in the vapour space region where cooling by evaporation of the contained material does not occur; the cylinder shell would weaken and rupture with a total loss of the contents, and the issuing mass of material would burn as a massive fireball.

The major consequences of a BLEVE are intense thermal radiation from the fireball, a blast wave and propelled fragments from the shattered vessel. These fragments may be projected to considerable distances. Analyses of the travel range of fragment missiles from a number of BLEVEs suggest that the majority land within 700 m from the incident. A blast wave from a BLEVE is fairly localised, but can cause significant damage to immediate equipment.

A BLEVE occurs sometime after the vessel has been engulfed in flames. Should an incident occur, that could result in a BLEVE, people should be evacuated to beyond the 1% fatality line.

No BLEVEs were predicted from the simulations.

## 5.5 Summary of Impacts

Maximum distances from the point of release to the 1% fatality are summarised for each scenario in Table 5-4.

**Table 5-4: Maximum distance to 1% fatality from the point of release**

Scenarios	Max. Distance to the 1% Fatality (m)
<b>Storage Vessel</b>	
<b>Apron Pump Bay</b>	
Avgas Tank - Pump failure Set	14
Avgas Tank - Pump leak Set	3
<b>Avgas T-11 Explosion</b>	
TNT Explosion	11
<b>Avgas T-12 Explosion</b>	
TNT Explosion	11
<b>Avgas T-13 Explosion</b>	
TNT Explosion	7
<b>Avgas North Bund</b>	
Avgas - Severe leak Set	23
Avgas Tank - Overfilling	23
Avgas - Catastrophic failure Set	28
<b>Avgas South Bund</b>	
Avgas - Severe leak Set	14
Avgas Tank - Overfilling	23
Avgas - Catastrophic failure Set	17
<b>Avgas South Offloading / Loading</b>	
Avgas Tanker - Hose failure Set	11
Avgas Tanker - Hose leak Set	3
Avgas Tanker - Failure Set	26
<b>Filter bund</b>	
Avgas - Severe leak Set	20

Scenarios	Max. Distance to the 1% Fatality (m)
<b>Jet A-1 after completion of Phase 2</b>	
Jet A-1 Tank - Overfilling	41
Jet A-1 - Catastrophic failure Set	58
Jet A-1 - Severe leak Set	41
<b>Jet A-1 Vertical Tanks Phase 3</b>	
Jet A-1 Vertical tank - Catastrophic failure Set	36
Jet A-1 Vertical Tank - Overfilling	26
Jet A-1 Vertical tank - Severe leak Set	26
<b>Loading Pump Bay</b>	
Avgas Tank - Pump failure Set	14
Avgas Tank - Pump leak Set	3
<b>Pipeline [2.38 km]</b>	
Apron pipeline - Pool Fire	42
<b>Road Tanker - Loading Bay</b>	
Road Tanker - Hose failure Set	13
Road Tanker - Hose leak Set	2
Road Tanker - Failure Set	23

## 6 RISK ANALYSIS

### 6.1 Background

It is important to understand the difference between hazard and risk.

A hazard is anything that has the potential to cause damage to life, property and the environment. Furthermore, it has constant parameters (like those of petrol, chlorine, ammonia, etc.) that pose the same hazard wherever present.

On the other hand, risk is the probability that a hazard will actually cause damage and goes along with how severe that damage will be (consequence). Risk is therefore the probability that a hazard will manifest itself. For instance, the risks of a chemical accident or spill depends upon the amount present, the process the chemical is used in, the design and safety features of its container, the exposure, the prevailing environmental and weather conditions and so on.

Risk analysis consists of a judgement of probability based on local atmospheric conditions, generic failure rates and severity of consequences, based on the best available technological information.

Risks form an inherent part of modern life. Some risks are readily accepted on a day-to-day basis, while certain hazards attract headlines even when the risk is much smaller, particularly in the field of environmental protection and health. For instance, the risk of one-in-ten-thousand chance of death per year associated with driving a car is acceptable to most people, whereas the much lower risks associated with nuclear facilities (one-in-ten-million chance of death per year) are deemed unacceptable.

A report by the British Parliamentary Office of Science and Technology (POST), entitled 'Safety in Numbers? Risk Assessment and Environmental Protection', explains how public perception of risk is influenced by a number of factors in addition to the actual size of the risk. These factors were summarised as follows in Table 6-1.

**Table 6-1: Influence of public perception of risk on acceptance of that risk, based on the POST report**

<b>Control</b>	People are more willing to accept risks they impose upon themselves or they consider to be 'natural' than to have risks imposed upon them
<b>Dread and Scale of Impact</b>	Fear is the greatest where the consequences of a risk are likely to be catastrophic, rather than spread over time
<b>Familiarity</b>	People appear more willing to accept risks that are familiar rather than new risks
<b>Timing</b>	Risks seem to be more acceptable if the consequences are immediate or short term, rather than if they are delayed (especially if they might affect future generations)
<b>Social Amplification and Attenuation</b>	Concern can be increased because of media coverage, graphic depiction of events or reduced by economic hardship
<b>Trust</b>	A key factor is how far the public trusts regulators, policy makers or industry; if these bodies are open and accountable (being honest, as well as admitting mistakes and limitations and taking account of differing views without disregarding them as emotive or irrational), then the public is more likely consider them credible

A risk assessment should be seen as an important component of ongoing preventative action, aimed at minimising or hopefully avoiding accidents. Reassessments of risks should therefore follow at regular intervals and after any changes that could alter the nature of the hazard, so contributing to an overall prevention programme and emergency response plan of the facility. Risks should be ranked with decreasing severity and the top risks reduced to acceptable levels.

Procedures for predictive hazard evaluation have been developed for the analysis of processes when evaluating very low probability accidents with very high consequences (for which there is little or no experience), as well as more likely releases with fewer consequences (for which there may be more information available). These addresses both the probability of an accident, as well as the magnitude and nature of undesirable consequences of that accident. Risk is usually defined as some simple function of both the probability and consequence.

## **6.2 Predicted Risk**

Physical and consequence modelling addresses the impact of a release of a hazardous component without taking into account probability of occurrence. This merely illustrates the significance and the extent of the impact in the event of a release. Modelling should also analyse cascading or knock-on effects due to incidents in the facility and the surrounding industries and suburbs.

During a risk analysis, the likelihood of various incidents is assessed, the consequences calculated and finally the risk for the facility is determined.



## 6.2.1 Generic Equipment Failure Scenarios

In order to characterise various failure events and assign a failure frequency, fault trees were constructed starting with a final event and working from the top down to define all initiating events and frequencies. Unless otherwise stated, analysis was completed by using published failure rate data (RIVM 2009). Equipment failures can occur in tanks, pipelines and other items handling hazardous chemical components. These failures may result in:

- Release of combustible, flammable and explosive components with fires or explosions upon ignition;
- Release of toxic or asphyxiant components.

### 6.2.1.1 Storage Vessels

Scenarios involving storage vessels can include catastrophic failures that would lead to leakage into the bund with a possible bund fire. A tank-roof failure could result in a possible tank-top fire. The fracture of a nozzle or transfer pipeline could also result in leakage into the bund.

Typical failure frequencies for atmospheric and pressure vessels are listed, respectively, in Table 6-2 and Table 6-3.

**Table 6-2: Failure frequencies for atmospheric vessels**

Event	Leak Frequency (per item per year)
Small leaks	$1 \times 10^{-4}$
Severe leaks	$3 \times 10^{-5}$
Catastrophic failure	$5 \times 10^{-6}$

**Table 6-3: Failure frequencies for pressure vessels**

Event	Failure Frequency (per item per year)
Small leaks	$1 \times 10^{-5}$
Severe leaks	$5 \times 10^{-7}$
Catastrophic failure	$5 \times 10^{-7}$

### 6.2.1.2 Transport and Process Piping

Piping may fail as a result of corrosion, erosion, mechanical impact damage, pressure surge (water hammer) or operation outside the design limitations for pressure and temperature. Failures caused by corrosion and erosion usually result in small leaks, which are easily detected and corrected quickly. For significant failures, the leak duration may be from 10 to 30 minutes before detection.

Generic data for leak frequency for process piping is generally expressed in terms of the cumulative total failure rate per year for a 10 m section of pipe for each pipe diameter. Furthermore, failure frequency normally decreases with increasing pipe diameter. Scenarios and failure frequencies for a pipeline apply to pipelines with connections, such as flanges, welds and valves.

The failure data given in Table 6-4 represents the total failure rate, incorporating all failures of whatever size and due to all probable causes. These frequencies are based on an assumed environment where no excessive vibration, corrosion, erosion or thermal cyclic stresses are expected. For incidents causing significant leaks (such as corrosion), the failure rate will be increased by a factor of 10.

**Table 6-4: Failure frequencies for process pipes**

Description	Frequencies of Loss of Containment for Process Pipes (per meter per year)	
	Full Bore Rupture	Leak
Nominal diameter < 75 mm	$1 \times 10^{-6}$	$5 \times 10^{-6}$
75 mm < nominal diameter < 150 mm	$3 \times 10^{-7}$	$2 \times 10^{-6}$
Nominal diameter > 150 mm	$1 \times 10^{-7}$	$5 \times 10^{-7}$

For scenarios and failure frequencies no distinction is made between process pipes and transport pipes, the materials from which a pipeline is made, the presence of cladding, the design pressure of a pipeline or its location on a pipe bridge. However, a distinction is made between aboveground pipes and underground pipes. The scenarios for aboveground pipes are given in Table 6-5, and those for underground pipes are given in Table 6-6.

Transport pipelines aboveground can be compared, under certain conditions, with underground pipes in a pipe bay. The necessary conditions for this are external damage being excluded, few to no flanges and accessories present and the pipe is clearly marked. In very specific situations the use of a lower failure frequency for transport pipes aboveground can be justified.

**Table 6-5: Failure frequencies for aboveground transport pipelines**

Description	Frequency (per meter per annum)		
	Nominal Diameter < 75 mm	75 mm > Nominal Diameter > 150 mm	Nominal Diameter > 150 mm
Full bore rupture	$1 \times 10^{-6}$	$3 \times 10^{-7}$	$1 \times 10^{-7}$
Leak with an effective diameter of 10% of the nominal diameter, up to a maximum of 50 mm	$5 \times 10^{-6}$	$2 \times 10^{-6}$	$5 \times 10^{-7}$

**Table 6-6: Failure frequencies for underground transport pipelines**

Description	Frequency (per meter per annum)		
	Pipeline in Pipe Lane <sup>1</sup>	Pipeline Complies with NEN 3650	Other Pipelines
Full bore rupture	$7 \times 10^{-9}$	$1.525 \times 10^{-7}$	$5 \times 10^{-7}$
Leak with an effective diameter of 20 mm	$6.3 \times 10^{-8}$	$4.575 \times 10^{-7}$	$1.5 \times 10^{-6}$

1 A pipeline located in a 'lane' is a pipeline located with a group of pipelines on a dedicated route. Loss-of-containment frequencies for this situation are lower because of extra preventive measures.

### 6.2.1.3 Pumps and Compressors

Pumps can be subdivided roughly into two different types, reciprocating pumps and centrifugal pumps. This latter category can be further subdivided into canned pumps (sealless pumps) and gasket (pumps with seals). A canned pump can be defined as an encapsulated pump where the process liquid is located in the space around the rotor (impeller), in which case gaskets are not used.

Compressors can also be subdivided roughly into reciprocating compressors and centrifugal compressors.

Failure rates for pumps and compressors are given in Table 6-7 and Table 6-8.

**Table 6-7: Failure frequency for centrifugal pumps and compressors**

Event	Canned (No Gasket) Frequency (per annum)	Gasket Frequency (per annum)
Catastrophic failure	$1.0 \times 10^{-5}$	$1.0 \times 10^{-4}$
Leak (10% diameter)	$5.0 \times 10^{-5}$	$4.4 \times 10^{-3}$

**Table 6-8: Failure frequency for reciprocating pumps and compressors**

Event	Frequency (per annum)
Catastrophic failure	$1.0 \times 10^{-4}$
Leak (10% diameter)	$4.4 \times 10^{-3}$

### 6.2.1.4 Loading and Offloading

Loading can take place from a storage vessel to a transport unit (road tanker, tanker wagon or ship) or from a transport unit to a storage vessel. The failure frequencies for loading and offloading arms are given in Table 6-9.

**Table 6-9: Failure frequencies for loading and offloading arms and hoses**

Event	Frequency (per hour)	
	Loading and Offloading Arms	Loading and Offloading Hoses
Rupture	$3 \times 10^{-8}$	$4 \times 10^{-6}$
Leak with effective diameter at 10% of nominal diameter to max. 50 mm	$3 \times 10^{-7}$	$4 \times 10^{-5}$

### 6.2.1.5 Road or Rail Tankers within the Establishment

Road or rail tankers are transport vehicles with fixed and removable tanks. In addition, they include battery wagons and, insofar as these are fitted on a transport vehicle, tank containers, swap-body tanks and MEGCs (multiple element gas containers).

The failure rate of tankers on an establishment is dependent on the pressure rating of the tank and is given in Table 6-10 and Table 6-11.

**Table 6-10: Failure frequencies for road tankers with an atmospheric tank**

Event	Frequency (per annum)
Instantaneous release of the entire contents	$1 \times 10^{-5}$
Release of contents from the largest connection	$5 \times 10^{-7}$

**Table 6-11: Failure frequencies for road tankers with a pressurised tank**

Event	Frequency (per annum)
Instantaneous release of the entire contents	$1 \times 10^{-7}$
Release of contents from the largest connection	$5 \times 10^{-7}$

It should be noted that no scenarios are included for loss of containment as a result of external damage to the tanker or fire in the surrounding areas. It is assumed that sufficient measures are taken to prevent external damage to the tanker.

### 6.2.1.6 Human Failure

Human error and failure can occur during any life cycle or mode of operation of a facility.

Human failure can be divided into the following categories:

- Human failure during design, construction and modification of the facility;
- Human failure during operation and maintenance;
- Human failure due to errors of management and administration.

Human failure during design, construction and modification is part of the generic failure given in this subsection. Human failure due to errors of organisation and management are influencing factors. Some of the types of tasks that have been evaluated for their rates of human failure, are given in Table 6-12.

**Table 6-12: Human failure rates of specific types of tasks (CPR 12E 2005; Red Book)**

<b>Tasks</b>	<b>Human Failure (events per year)</b>
Totally unfamiliar, performed at speed with no real idea of likely consequences	0.55
Failure to carry out rapid and complex actions to avoid serious incident such as an explosion	0.5
Complex task requiring high level of comprehension and skill	0.16
Failure to respond to audible alarm in control room within 10 minutes	$1.0 \times 10^{-1}$
Failure to respond to audible alarm in quiet control room by some more complex action, such as going outside and selecting one correct value among many	$1.0 \times 10^{-2}$
Failure to respond to audible alarm in quiet control room by pressing a single button	$1.0 \times 10^{-3}$
Omission or incorrect execution of step in a familiar start-up routine	$1.0 \times 10^{-3}$
Completing a familiar, well-designed, highly-practiced, routine task occurring several times per hour, performed to highest possible standards by a highly-motivated, highly-trained and experienced person totally aware of implications of failures, with time to correct potential error but without the benefit of significant job aids	$4.0 \times 10^{-4}$

### 6.2.1.7 Ignition Probability of Flammable Gases and Liquids

Estimation of probability of an ignition is a key step in assessment of risk for installations where flammable liquids or gases are stored. There is a reasonable amount of data available relating to characteristics of ignition sources and effects of release type and location.

Probability of ignition for stationary installations is given in Table 6-13 (along with classification of flammable substances in Table 6-14). These can be replaced with ignition probabilities related to surrounding activities. For example, probability of a fire from a flammable release at an open flame would increase to a value of 1.

**Table 6-13: Probability of direct ignition for stationary installations (RIVM 2009)**

Substance Category	Source-Term Continuous	Source-Term Instantaneous	Probability of Direct Ignition
Category 0 Average to high reactivity	< 10 kg/s	< 1000 kg	0.2
	10 – 100 kg/s	1000 – 10 000 kg	0.5
	> 100 kg/s	> 10 000 kg	0.7
Category 0 Low reactivity	< 10 kg/s	< 1000 kg	0.02
	10 – 100 kg/s	1000 – 10 000 kg	0.04
	> 100 kg/s	> 10 000 kg	0.09
Category 1	All flow rates	All quantities	0.065
Category 2	All flow rates	All quantities	0.0043 <sup>1</sup>
Category 3 Category 4	All flow rates	All quantities	0

**Table 6-14: Classification of flammable substances**

Substance Category	Description	Limits
Category 0	Extremely flammable	Liquids, substances and preparations that have a flashpoint lower than 0°C and a boiling point (or the start of the boiling range) less than or equal to 35°C Gaseous substances and preparations that may ignite at normal temperature and pressure when exposed to air
Category 1	Highly flammable	Liquids, substances and preparations that have a flashpoint of below 21°C
Category 2	Flammable	Liquids, substances and preparations that have a flashpoint equal to 21°C and less than 55°C
Category 3		Liquids, substances and preparations that have a flashpoint greater than 55°C and less than or equal to 100°C
Category 4		Liquids, substances and preparations that have a flashpoint greater than 100°C

<sup>1</sup> This value is taken from the CPR 18E (Purple Book; 1999). RIVM (2009) gives the value of delayed ignition as zero. RISCO (PTY) LTD believes the CPR 18E is more appropriate for warmer climates and is a conservative value.

## **6.3 Risk Calculations**

### **6.3.1 Maximum Individual Risk Parameter**

Standard individual risk parameters include: average individual risk; weighted individual risk; maximum individual risk; and, the fatal accident rate. The lattermost parameter is more applicable to occupational exposures.

Only the maximum individual risk (MIR) parameter will be used in this assessment. For this parameter, frequency of fatality is calculated for an individual who is presumed to be present at a specified location. This parameter (defined as the consequence of an event multiplied by the likelihood of the event) is not dependent on knowledge of populations at risk. So, it is an easier parameter to use in the predictive mode than average individual risk or weighted individual risk. The unit of measure is the risk of fatality per person per year.

### **6.3.2 Acceptable Risks**

The next step, after having characterised a risk and obtained a risk level, is to recommend whether the outcome is acceptable.

In contrast to the employees at a facility, who may be assumed to be healthy, the adopted exposure assessment applies to an average population group that also includes sensitive subpopulations. Sensitive subpopulation groups are those people that for reasons of age or medical condition, have a greater than normal response to contaminants. Health guidelines and standards used to establish risk normally incorporate safety factors that address this group.

Among the most difficult tasks of risk characterisation is the definition of acceptable risk. In an attempt to account for risks in a manner similar to those used in everyday life, the UK Health and Safety Executive (HSE) developed the risk ALARP triangle. Applying the triangle involves deciding:

- Whether a risk is so high that something must be done about it;
- Whether the risk is or has been made so small that no further precautions are necessary;
- If a risk falls between these two states so that it has been reduced to levels as low as reasonably practicable (ALARP).

This is illustrated in Figure 6-1.

ALARP stands for 'as low as reasonably practicable'. As used in the UK, it is the region between that which is intolerable, at  $1 \times 10^{-4}$  per year, and that which is broadly acceptable, at  $1 \times 10^{-6}$  per year. A further lower level of risk, at  $3 \times 10^{-7}$  per year, is applied to either vulnerable or very large populations for land-use planning.

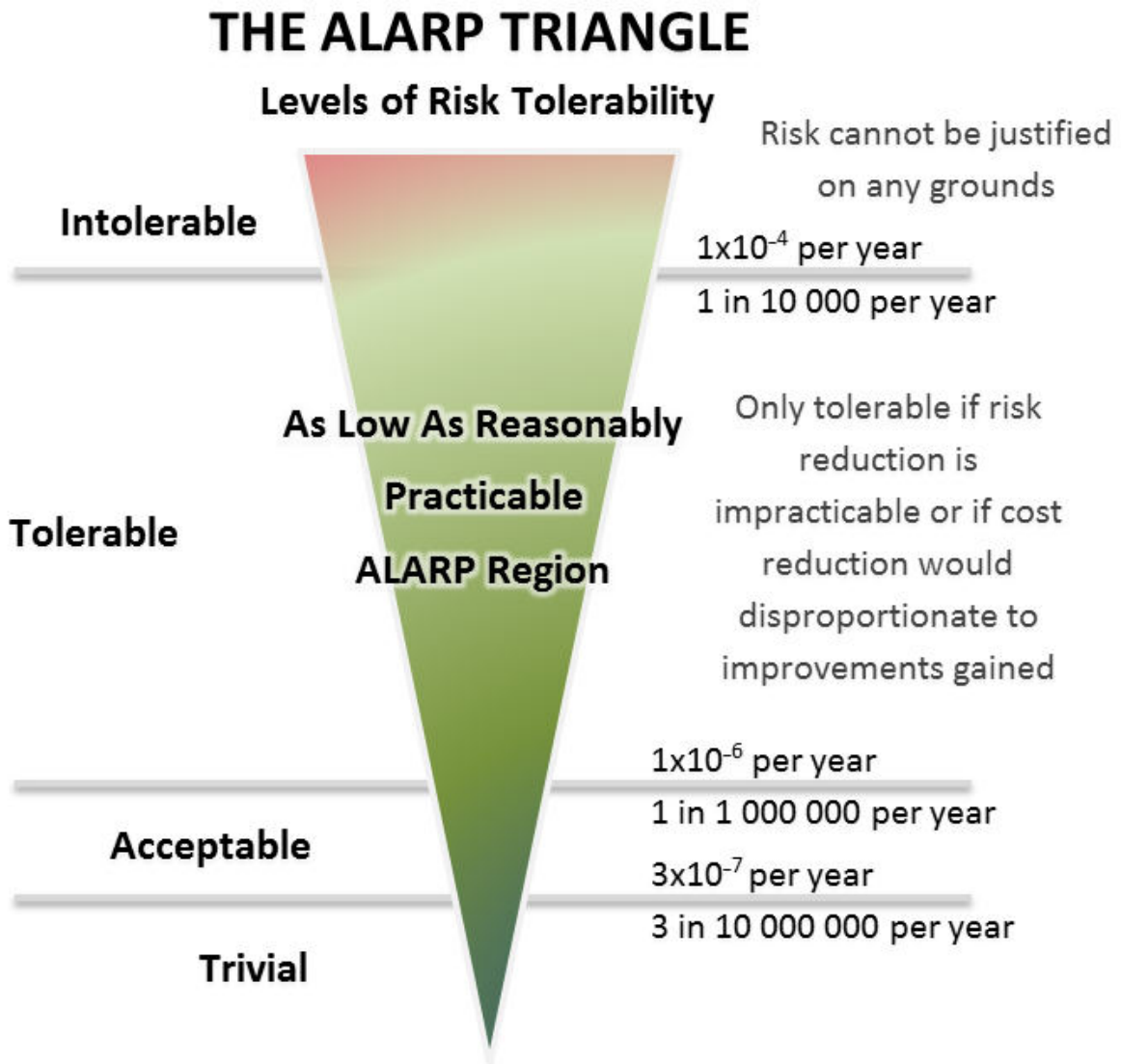

Figure 6-1: UK HSE decision-making framework



It should be emphasised that the risks considered acceptable to employees are different to those considered acceptable to the public. This is due to the fact that employees have personal protection equipment (PPE), are aware of the hazards, are sufficiently mobile to evade or escape the hazards and receive training in preventing injuries.

The HSE (UK) gives more detail on the word practicable in the following statement:

“ *In essence, making sure a risk has been reduced to ALARP is about weighing the risk against the sacrifice needed to further reduce it. The decision is weighted in favour of health and safety because the presumption is that the duty-holder should implement the risk reduction measure. To avoid having to make this sacrifice, the duty-holder must be able to show that it would be grossly disproportionate to the benefits of risk reduction that would be achieved. Thus, the process is not one of balancing the costs and benefits of measures but, rather, of adopting measures except where they are ruled out because they involve grossly disproportionate sacrifices. Extreme examples might be:*

- *To spend £1m to prevent five staff members suffering bruised knees is obviously grossly disproportionate; but,*
- *To spend £1m to prevent a major explosion capable of killing 150 people is obviously proportionate.*

*Proving ALARP means that if the risks are lower than  $1 \times 10^{-4}$  fatalities per person per year, it can be demonstrated that there would be no more benefit from further mitigation, sometimes using cost benefit analysis.* “

### 6.3.3 Land Planning

There are no legislative land-planning guidelines in South Africa and in many parts of the world. Further to this, land-planning guidelines vary from one country to another, and thus it is not easy to benchmark the results of this study to international criteria. In this instance, RISCOM would only advise on applicable land planning and would require governmental authorities to make final decisions.

Land zoning applied in this study follows the HSE (UK) approach of defining the area affected into three zones, consistent to the ALARP approach (HSE 2011).

The three zones are defined as follows:

- The inner zone is enclosed by the risk of  $1 \times 10^{-5}$  fatalities per person per year isopleth;
- The middle zone is enclosed by the risk of  $1 \times 10^{-5}$  fatalities per person per year and the risk of  $1 \times 10^{-6}$  fatalities per person per year isopleths;
- The outer zone is enclosed by the risk  $1 \times 10^{-6}$  fatalities per person per year and the risk of  $3 \times 10^{-7}$  fatalities per person per year isopleths.

The risks decrease from the inner zone to the outer zone as shown in Figure 6-2 and Figure 6-3.

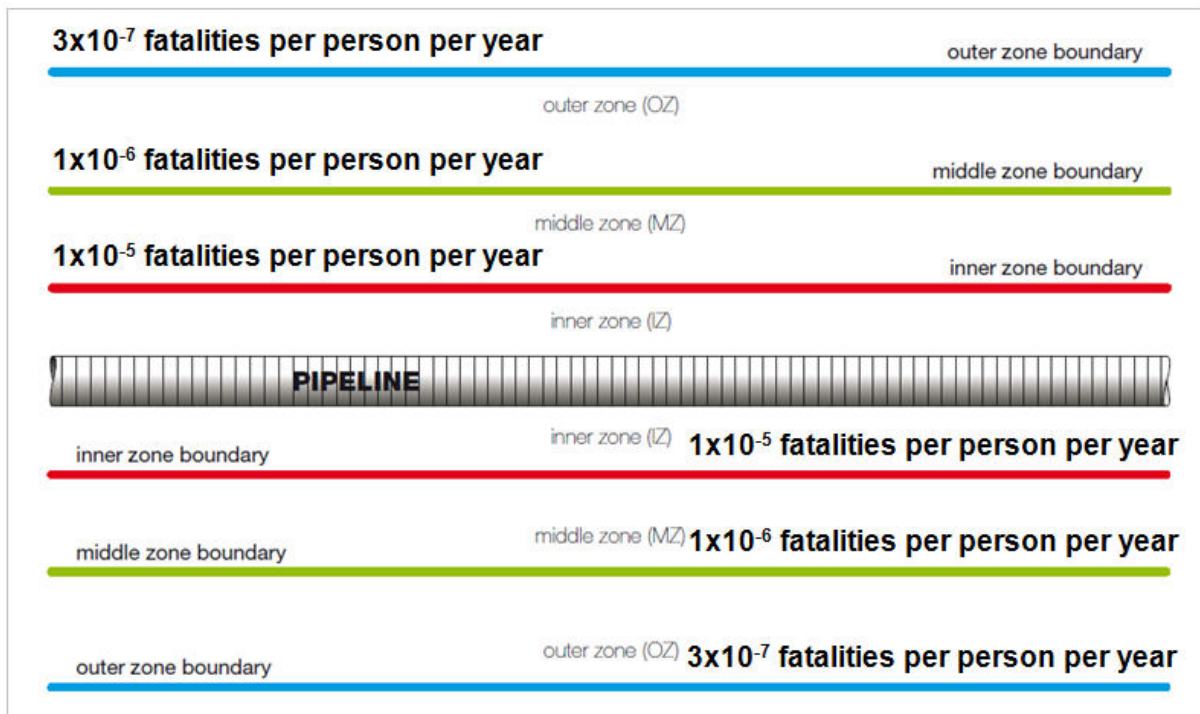
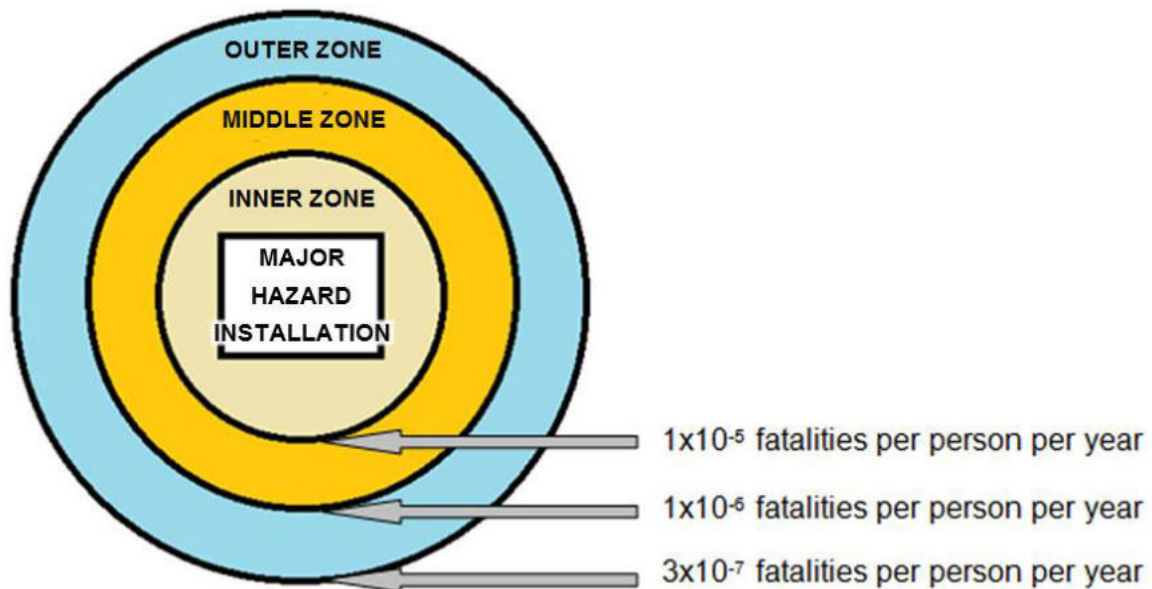

Figure 6-2: Town-planning zones for pipelines



**Figure 6-3: Town-planning zones**

Once the zones are calculated, the HSE (UK) methodology then determines whether a development in a zone should be categorised as ‘advised against’ (AA) or as ‘don’t advise against’ (DAA), depending on the sensitivity of the development, as indicated in Table 6-15. There are no land-planning restrictions beyond the outer zone.

**Table 6-15: Land-use decision matrix**

Level of Sensitivity	Development in Inner Zone	Development in Middle Zone	Development in Outer Zone
1	DAA	DAA	DAA
2	AA	DAA	DAA
3	AA	AA	DAA
4	AA	AA	AA

The sensitivity levels are based on a clear rationale: progressively more severe restrictions are to be imposed as the sensitivity of the proposed development increases.

There are four sensitivity levels, with the sensitivity for housing defined as follows:

- Level 1 is based on workers who have been advised of the hazards and are trained accordingly;
- Level 2 is based on the general public at home and involved in normal activities;
- Level 3 is based on the vulnerability of certain members of the public (e.g., children, those with mobility difficulties or those unable to recognise physical danger);
- Level 4 is based on large examples of Level 2 and of Level 3.

Refer to Appendix B for detailed planning advice for developments near hazardous installations (PADHI) tables. These tables illustrate how the HSE land-use decision matrix, are generated by using the three zones and the four sensitivity levels, and is applied to a variety of development types.

## **6.4 Risk Scenarios**

### **6.4.1 Lethal Dosages from Accidental Toxic Releases**

Quantitative health risk assessment incorporates various distinct stages, including hazard assessment, dose-response analysis, exposure assessment and risk characterisation. The process of a hazard assessment is aimed at determining whether particular substances cause adverse impacts on human health.

The quantification of the adverse impacts associated with a substance is made possible through dose-response analysis and exposure assessment. By combining information generated through a hazard assessment and dose-response analysis, the overall risk posed by a particular component on human health may be characterised.

### **6.4.2 Accidental Fires and Explosions**

Relatively large quantities of combustible, flammable and explosive components are stored on, delivered to or produced at the proposed CWA site. Fires and explosions may result with accidental release and ignition of these components. Scenarios that could result in large fires were developed and summarised in Appendix C. Risks were calculated by using generic failure rates.

**6.4.2.1 At the end of Phase 1**

The risk at the end of Phase 1 is shown in Figure 6-4, and the kerbside installation is shown in Figure 6-5.

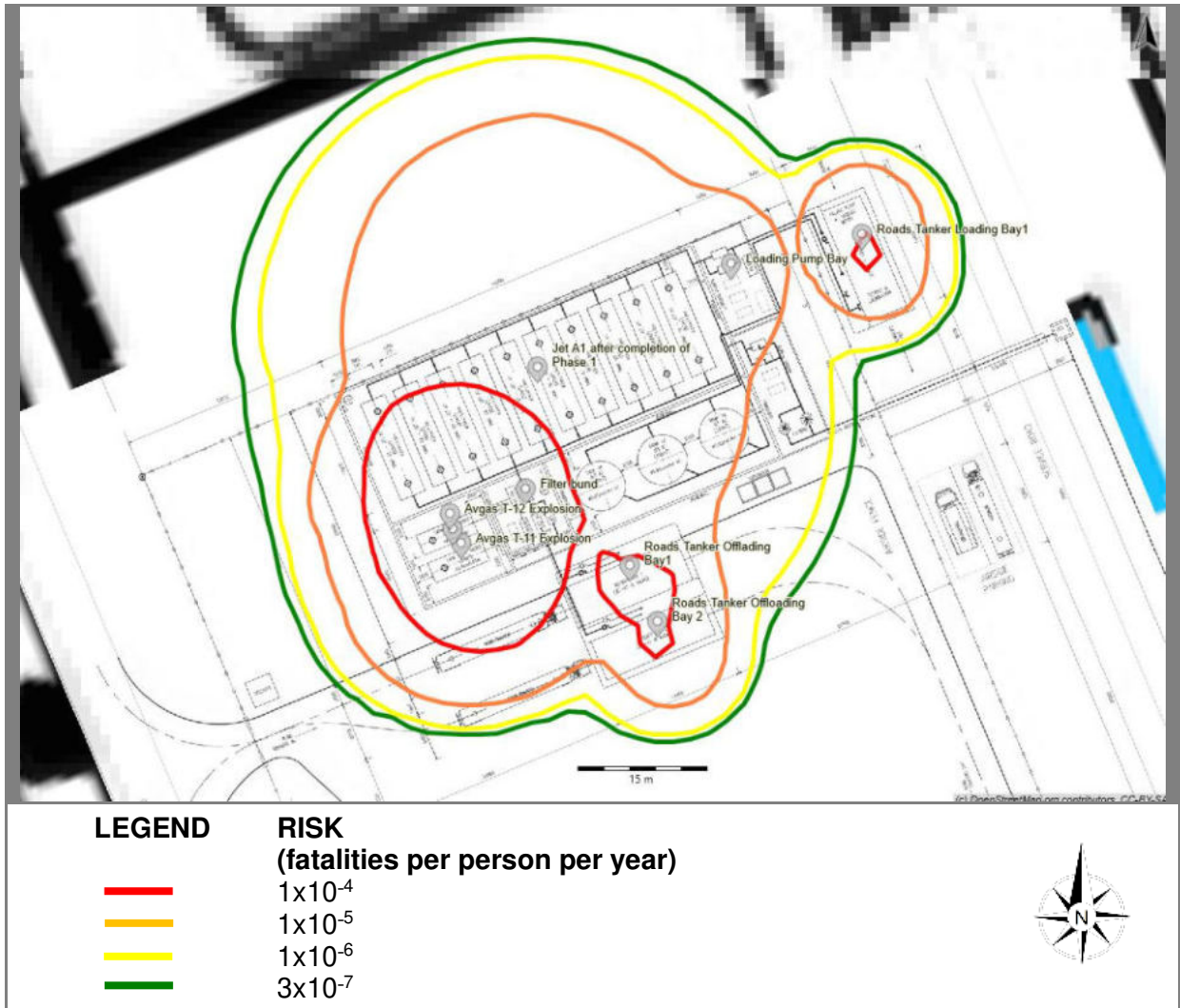

**Figure 6-4: Lethal probability isopleths associated with the fuel storage tank farm at the end of Phase 1**

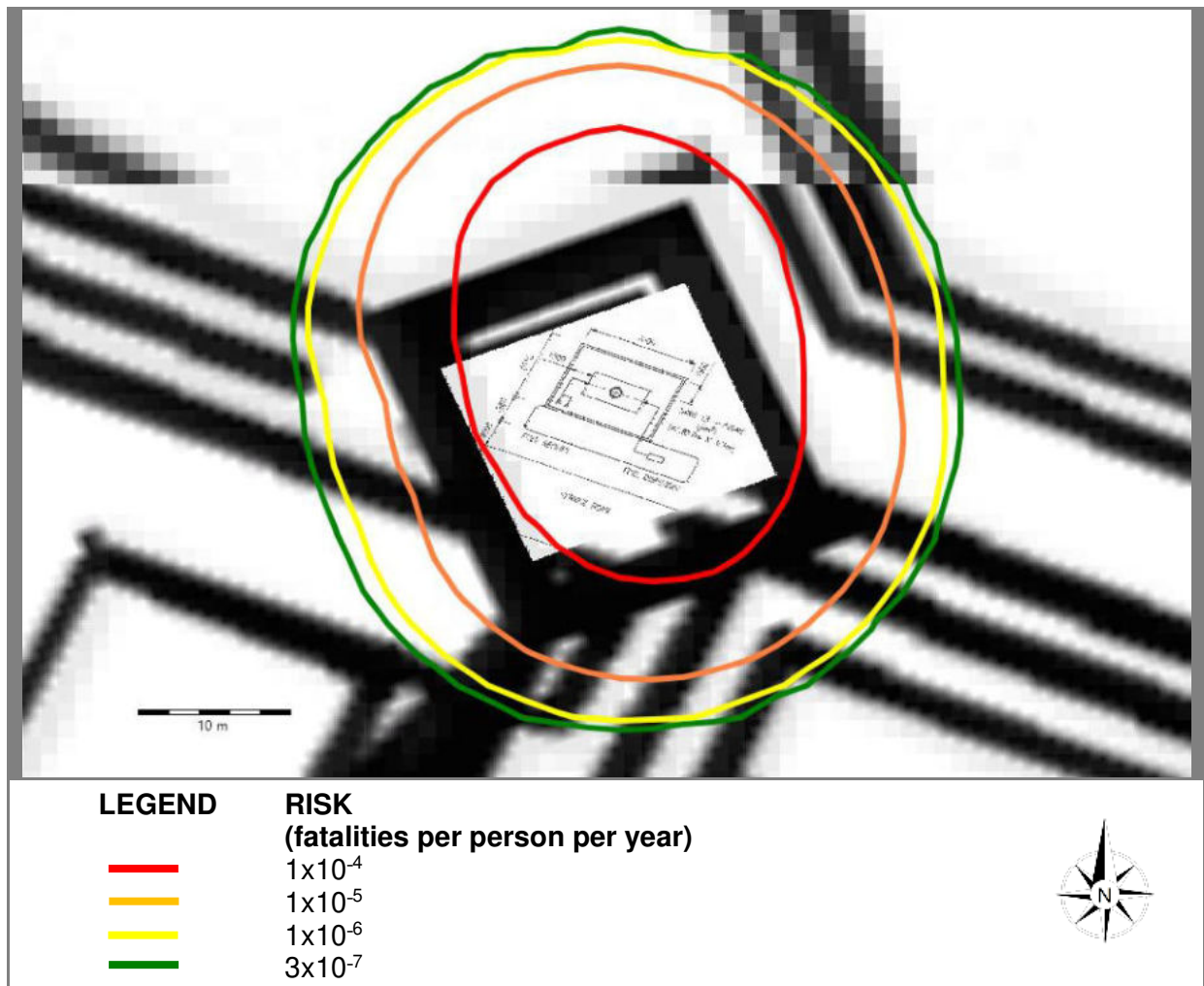

**Figure 6-5: Lethal probability isopleths associated with the Avgas kerbside installation the end of Phase 1**

Risks greater than  $1 \times 10^{-4}$  fatalities per person per year, are considered tolerable for industrial areas, but excessive for residential areas. The  $1 \times 10^{-4}$  fatalities per person per year did not extend into areas occupied by the general public on the proposed CWA site.

The risk of  $3 \times 10^{-7}$  fatalities per person per year isopleth indicates the extent for land-use that would be suitable for vulnerable populations, such as hospitals, retirement homes, nursery schools, prisons, large gatherings in the open, and so forth. As the risks did not extend into areas occupied by the general public, no land planning would be required.

The risk from the installation of Phase 1 would be considered acceptable.



**6.4.2.2 At the end of Phase 2**

The risk at the end of phase 2 is shown in Figure 6-6, and is almost identical to that of Phase 1.

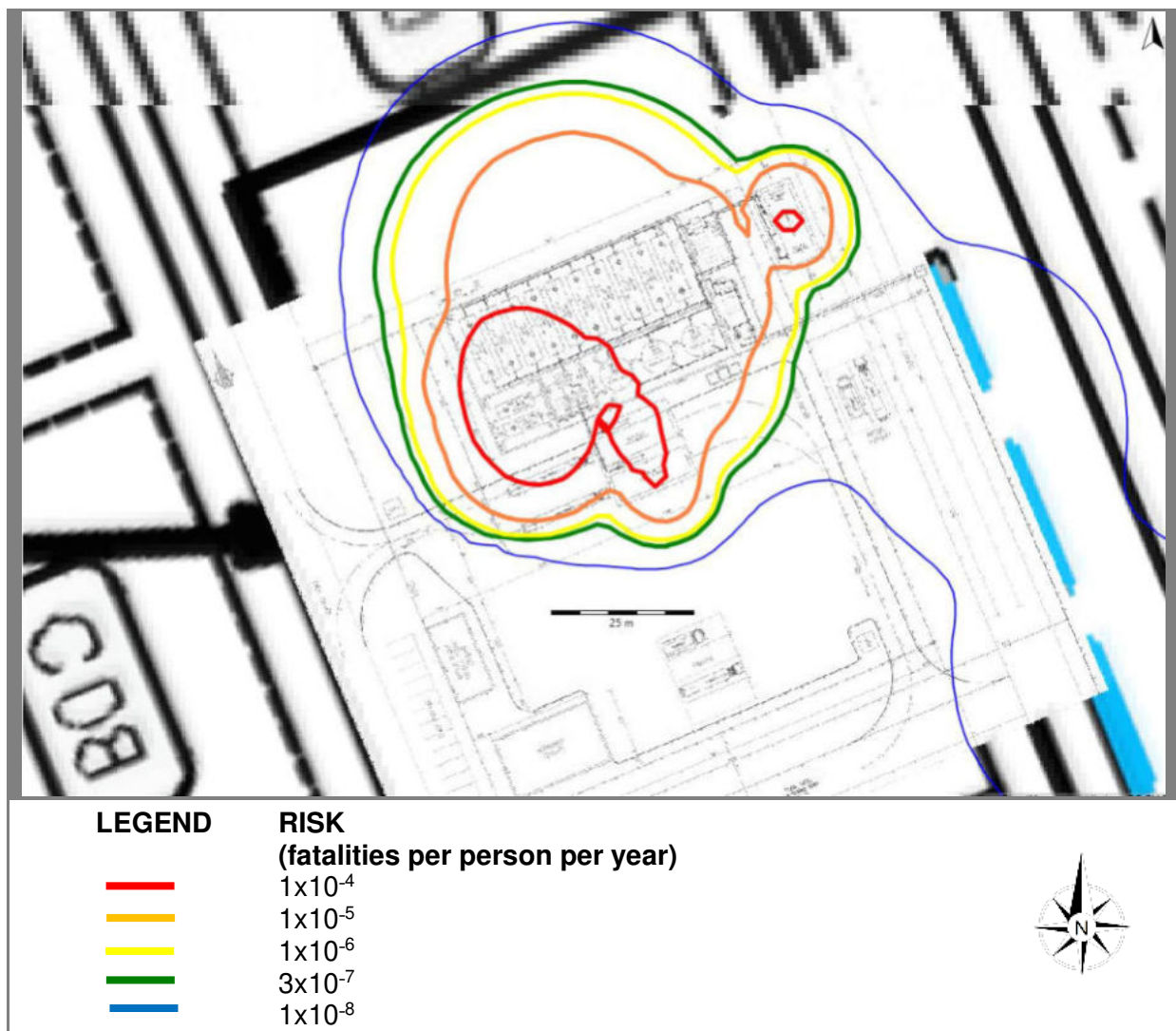

**Figure 6-6: Lethal probability isopleths associated with the fuel storage tank farm the end of Phase 2**

### 6.4.2.3 At the end of Phase 3

The risk at the end of phase 3 is shown in Figure 6-7, and is slightly larger than that of Phase 1. The apron pumps and pipelines of Phase 3 did not significantly increase the risks of the facility. Normally the  $1 \times 10^{-8}$  fatality per person per year isopleth is not shown on the risk maps, as this risk is indicative of a very low or trivial risk. In this instance, the pipeline risks are shown indicating a low risk, providing the pipeline remains at a relatively low pressure and flowrate, as provided, and is out of the way for accidental damage from vehicles etc.

The risks after Phase 3 would not extend into the terminal or areas occupied by the general public. Furthermore, the risk to the workers would be considered tolerable.



**Figure 6-7: Lethal probability isopleths associated with the fuel storage tank farm the end of Phase 3**

Risks greater than  $1 \times 10^{-4}$  fatalities per person per year, are considered tolerable for industrial areas, but excessive for residential areas, extends beyond the proposed CWA site to the south.



The risk of  $3 \times 10^{-7}$  fatalities per person per year isopleth indicates the extent for land-use that would be suitable for vulnerable populations, such as hospitals, retirement homes, nursery schools, prisons, large gatherings in the open, and so forth.

The risk of  $1 \times 10^{-8}$  fatalities per person per year is not normally shown, as it indicates trivial risks. The apron pipeline is shown as  $1 \times 10^{-8}$  fatalities per person per year and indicates an acceptable risk.

## **7 REDUCTION OF RISK**

This study found that the proposed CWA facility in Durbanville would be classified as a Low Hazard Establishment Major Hazard Installation, resulting in the risks to the general public being considered acceptable.

Mitigations that may be considered, but not limited, to reduce risks to acceptable levels are listed in the following subsections.

Implementation of any mitigations should always be done in accordance with recognised engineering practices, by using applicable codes and standards that should be based on the benefit versus cost principle.

### **7.1 Mitigation**

As mentioned, the scenarios with the highest risk rankings are the overfilling of the tanks. Suggested mitigation is listed in the following subsections.

#### **7.1.1 Containment**

Secondary containment for the storage and offloading / loading of road tankers has been described. However, pooling of fuels below the road tankers, from a loss of containment, should be prevented.

#### **7.1.2 Overfilling**

Overfilling instrumentation has been described. However, compliance with IEC61511 should be contemplated. This is described more in Section 7.1.7.

#### **7.1.3 Process Hazard Analysis (PHA)**

Hazardous areas should be reviewed by using a detailed Process Hazard Analysis (PHA)<sup>1</sup>, such as a HAZOP study that should be completed to identify potential hazards, and suggest further mitigation for safer operations. Due to the seriousness of the hazardous material stored, transported and produced on site, it is suggested that a detailed PHA / HAZOP study should be completed by an independent chairman, who is registered with the Engineering Council of South Africa. Furthermore, any instruments used should incorporate the findings of a SIL assessment defined in IEC 61511.

---

1 A Process Hazard Analysis is not a regulated activity, but merely identifies potential hazards and recommends mitigation.

#### **7.1.4 Ignition Sources**

Ignition sources near the depot must be minimised as far as possible. This is particularly relevant with the fuel storage area.

A hazardous area classification as per SANS 10108 must be developed for all flammable materials. Only suitable instrumentation and electrical equipment should be installed in accordance with the requirement of the code.

#### **7.1.5 Emergency Shut Down System (ESD)**

The fast detection of a loss of containment with appropriate shut-down action to limit the amount of Jet A-1 and Avgas released, will assist in the reduction of the site risks.

#### **7.1.6 Codes and Standards**

Applicable international best practice production and guidelines or equivalent international recognised codes of good design and practice of installations, must be incorporated in the designs. This implies that best practices would be applied to the design and operation of the proposed site.

#### **7.1.7 Safety Instrumented Systems**

IEC 61508/61511 (Safety Instrumented Systems) are codes specifically related to the instrumentation requirements for adequate protection from hazards in chemical plants and applicable for the life cycle of the plant. These codes are aimed at reducing risks to surrounding populations to acceptable levels.

The significance of these codes is that the designs would be evaluated against the criteria of the code, and that instrumentation with specific failure rates would be specified, as well as the minimum periods of checking. Thus, the selection of instrumentation is not based on price alone. Further to this, instrumentation cannot be reduced or changed without reviewing the code. The specification of this code implies that designs presented at the EIA and MHI evaluations cannot be altered at construction for the sole function by reducing costs. Moreover, the code ensures that the plant would continue to maintain the safety functions for the *life cycle* of the plant, and by retaining a safe working environment for both workers and the public.

The European standards body, CENELEC, has adopted the standard as EN 61511. This means that in each of the member states of the European Union, the standard is published as a national standard. For example, in Great Britain, it is published by the national standards body, BSI, as BS EN 61511. The content of these national publications is identical to that of IEC 61511. Note, however, that BS EN 61511 is not harmonized under any directive of the European Commission.

In the United States, ANSI/ISA 84.00.01-2004 was issued in September 2004. It primarily mirrors IEC 61511 in content with the exception that it contains a grandfathering clause.

Compliance with IEC 61508 and IEC 61511 (or ANSI/ISA 84.00.01-2004) would be a requirement in many countries around the world to achieve an acceptable risk to both workers and the public.

Demonstrating compliance with the IEC 61508/11 can be achieved only once full-detailed designs have been completed and is thus premature at this stage in the project.

## **8 CONCLUSIONS**

Risk calculations are not precise. Accuracy of predictions is determined by the quality of base data and expert judgements.

This risk assessment included the consequences of fires and explosions at the proposed CWA facility in Durbanville. A number of well-known sources of incident data were consulted and applied to determine the likelihood of an incident to occur.

This risk assessment was performed with the assumption that the site would be maintained to an acceptable level and that all statutory regulations would be applied. It was also assumed that the detailed engineering designs would be done by competent people and would be correctly specified for the intended duty. For example, it was assumed that tank wall thicknesses have been correctly calculated, that vents have been sized for emergency conditions, that instrumentation and electrical components comply with the specified electrical area classification, that material of construction is compatible with the products, etc.

It is the responsibility of the owners and their contractors to ensure that all engineering designs would have been completed by competent persons and that all pieces of equipment would have been installed correctly. All designs should be in full compliance with (but not limited to) the Occupational Health and Safety Act 85 of 1993 and its regulations, the National Buildings Regulations and the Buildings Standards Act 107 of 1977, as well as the local bylaws.

A number of incident scenarios were simulated, taking into account the prevailing meteorological conditions, and described in the report.

### **8.1 Hazardous Materials**

The hazardous materials identified included Jet A-1 and Avgas fuels. Both these materials are considered flammable, but not acutely toxic when inhaled.

### **8.2 Notifiable Substances**

The General Machinery Regulation 8 and its Schedule A on notifiable substances requires any employer who has a substance equal to or exceeding the quantity listed in the regulation to notify the divisional director. A site is classified as a Major Hazard Installation if it contains one or more notifiable substances or if the off-site risk is sufficiently high. The latter can only be determined from a quantitative risk assessment.

No material to be stored on site is listed as notifiable.

### **8.3 Bulk Fuel Tank Farm**

Pool fires and flash fires from a loss of containment at the storage and offloading installations of Jet A-1 and Avgas and subsequent fires were simulated. Tank explosions from Avgas were also simulated.

The 1% fatality for Avgas and Jet A-1 from fires, could extend a short distance over the tank farm boundary. However, these impacts would not extend to areas occupied by the general public or to the runway and airplanes.

Risks greater than  $1 \times 10^{-4}$  fatalities per person per year, are considered tolerable for industrial areas, but excessive for residential areas. The  $1 \times 10^{-4}$  fatalities per person per year did not extend into areas occupied by the general public on the proposed CWA site.

The risk of  $3 \times 10^{-7}$  fatalities per person per year isopleth indicates the extent for land-use that would be suitable for vulnerable populations, such as hospitals, retirement homes, nursery schools, prisons, large gatherings in the open, and so forth. As the risks did not extend into areas occupied by the general public, no land planning would be required.

The risk from the installations after Phase 3 would be considered acceptable.

#### **8.4 Avgas Kerbside Filling**

The kerbside filling will consist of a 9 m<sup>2</sup> Avgas tank with an offloading area.

Pool fires from a loss of containment would extend beyond the secondary containment, but would not extend to the area occupied by the general public.

Risks greater than  $1 \times 10^{-4}$  fatalities per person per year, are considered tolerable for industrial areas, but excessive for residential areas. The  $1 \times 10^{-4}$  fatalities per person per year did not extend into areas occupied by the general public on the proposed CWA site.

The risk of  $3 \times 10^{-7}$  fatalities per person per year isopleth indicates the extent for land-use that would be suitable for vulnerable populations, such as hospitals, retirement homes, nursery schools, prisons, large gatherings in the open, and so forth. As the risks did not extend into areas occupied by the general public, no land planning would be required.

The risk from the kerbside filling would be considered acceptable.

#### **8.5 Apron Pipeline**

The apron pipeline is expected to be constructed during Phase 3. The pipeline would be located in a chamber. Thus, a loss of containment will firstly fill the chamber and then overflow. For this study, the maximum area from a pool formed from a loss of containment was limited to 300 m<sup>2</sup>.

The 1% fatality from the apron pipeline could extend 41 m from the pipeline. However, the risks from the apron pipeline failure would be considered acceptable.

#### **8.6 Impacts onto Neighbouring Properties, Residential Areas and Major Hazard Installations**

Impacts from Jet A-1 and Avgas would not extend into areas occupied by the general public.

## 8.7 Major Hazard Installation

The expected MHI hazard tier for each phase of the fuel storage projects, is given in Table 8-1.

**Table 8-1: Expected establishment hazardous tier per project phase**

<b>Phase</b>	<b>Avgas Inventory (t)</b>	<b>Jet A-1 Inventory (t)</b>	<b>Total (t)</b>	<b>Hazard Tier</b>
1	394.2	48.3	442.5	Low Hazard
2	664	48.3	712.3	Low Hazard
2	1864	38.3	1 902.3	Low Hazard

The requirements of approvals and registration under the MHI regulations should be reviewed for adequate preparation in completing the MHI risk assessment, as required by legislation prior to construction.

## 9 RECOMMENDATIONS

As a result of the risk assessment study conducted for the proposed CWA facility in Durbanville a number of events were found to have risks beyond the fuel tank farm boundary. These risks could be mitigated to acceptable levels, as shown in the report.

RISCOM did not find any fatal flaws that would prevent the project proceeding to the detailed engineering phase of the project.

RISCOM would support the project with the following conditions:

- Compliance with all statutory requirements, i.e., pressure vessel designs;
- Compliance with applicable SANS codes, i.e., SANS 10087, SANS 10089, SANS 10108, etc.;
- Incorporation of applicable guidelines or equivalent international recognised codes of good design and practice into the designs;
- Completion of a recognised process hazard analysis (such as a HAZOP study, FMEA, etc.) on the proposed facility prior to construction to ensure that the design and operational hazards have been identified and adequate mitigation are put in place;
- Full compliance with IEC 61511 (Safety Instrument Systems) standards or equivalent to ensure that adequate protective instrumentation is included in the design and would remain valid for the full life cycle of the tank farm: This is particularly relevant to the overfilling of the storage tanks and applicable shutdown systems:
  - Including demonstration from the designer that sufficient and reliable instrumentation would be specified and installed at the facility;
- Preparation and issuing of a safety document detailing safety and design features reducing the impacts from fires, explosions and flammable atmospheres to the MHI assessment body at the time of the MHI assessment:
  - Including compliance to statutory laws, applicable codes and standards and world's best practice;
  - Including the listing of statutory and non-statutory inspections, giving frequency of inspections;
  - Including the auditing of the built facility against the safety document;
  - Noting that codes such as IEC 61511 can be used to achieve these requirements;
- Demonstration by CWA or their contractor that the final designs would reduce the risks posed by the installation to internationally acceptable guidelines;
- Signature of all terminal designs by a professional engineer registered in South Africa in accordance with the Professional Engineers Act, who takes responsibility for suitable designs;
- Completion of an emergency preparedness and response document for on-site and off-site scenarios prior to initiating the MHI risk assessment (with input from the local authorities);
- Permission not being granted for increases to the product list or product inventories without redoing part of or the full EIA;
- Final acceptance of the facility risks with an MHI risk assessment that must be completed in accordance to the MHI regulations:
  - Basing such a risk assessment on the final design and including engineering mitigation.



## 10 REFERENCES

- BUNCEFIELD MAJOR INCIDENT INVESTIGATIONS BOARD (2007). *Recommendations on the Design and Operation of Fuel Storage Sites*. [report]. Available at: Buncefield Investigation Website. <<http://www.buncefieldinvestigation.gov.uk/reports/index.htm>> (Accessed 5 February 2012).
- CPR 12E (2005). *Methods for Determining and Processing Probabilities ("Red Book")*. Fourth Edition. Apeldoorn: TNO.
- CPR 14E (1997). *Methods for the Calculation of Physical Effects ("Yellow Book")*. Third Edition. Apeldoorn: TNO.
- CPR 16E (1992). *Methods for the Determination of Possible Damage ("Green Book")*. First Edition. Apeldoorn: TNO.
- CPR 18E (1999). *Guidelines for Quantitative Risk Assessment ("Purple Book")*. First Edition, Apeldoorn: TNO.
- DOL (2023). *Occupation Health and Safety Act, 1993: Major Hazard Installation Regulations Vol 691, No 47970*. Regulation Gazette. No. 11536 Pretoria, Republic of South Africa: Department of Employment and Labour.
- HSE (2011). *PADHI: HSE's Land Use Planning Methodology*. Available at: Health and Safety Executive Website. <<http://www.hse.gov.uk/landuseplanning/methodology.htm>>
- RIVM (2009). *Reference Manual BEVI Risk Assessments*. Edition 3.2. Bilthoven, the Netherlands: National Institute of Public Health and the Environment (RIVM).
- STEPHENS, M. (1970). *Minimizing Damage to Refineries*. US Dept. of the Interior, Offices of Oil and Gas.

## 11 ABBREVIATIONS AND ACRONYMS

<b>AIA</b>	See <b>Approved Inspection Authority</b>
<b>ALARP</b>	The UK Health and Safety Executive (HSE) developed the risk <b>ALARP</b> triangle, in an attempt to account for risks in a manner similar to those used in everyday life. This involved deciding: <ul style="list-style-type: none"> <li>• Whether a risk is so high that something must be done about it;</li> <li>• Whether the risk is or has been made so small that no further precautions are necessary;</li> <li>• Whether a risk falls between these two states and has been reduced to levels '<b>as low as reasonably practicable</b>' (ALARP).</li> </ul> Reasonable practicability involves weighing a risk against the trouble, time and money needed to control it.
<b>API</b>	The <b>American Petroleum Institute</b> is the largest U.S. trade association for the oil and natural gas industry. It claims to represent nearly 600 corporations involved in production, refinement, distribution, and many other aspects of the petroleum industry.
<b>Approved Inspection Authority</b>	An <b>approved inspection authority</b> (AIA) is defined in the Major Hazard Installation regulations (July 2001)
<b>ATG</b>	An <b>Automatic Tank Gauge (ATG)</b> is a computerized system that automatically evaluates changes in product volume that might suggest a possible leaking tank. The tank gauge is connected to a probe inside the tank that is permanently installed through the top of the tank.
<b>Blast Overpressure</b>	<b>Blast overpressure</b> is a measure used in the multi-energy method to indicate the strength of the blast, indicated by a number ranging from 1 (for very low strengths) up to 10 (for detonative strength).
<b>BLEVE</b>	<b>Boiling liquid expanding vapour explosions</b> result from the sudden failure of a vessel containing liquid at a temperature above its boiling point. A <b>BLEVE</b> of flammables results in a large fireball.
<b>CWA</b>	<b>Cape Winelands Airport</b>
<b>Detonation</b>	<b>Detonation</b> is a release of energy caused by extremely rapid chemical reaction of a substance, in which the reaction front of a substance is determined by compression beyond the auto-ignition temperature.
<b>EIA</b>	<b>Environmental impact assessment</b> Environmental assessment is the assessment of the environmental consequences of a plan, policy, program, or actual projects prior to the decision to move forward with the proposed action.
<b>Emergency Plan</b>	An <b>emergency plan</b> is a plan in writing that describes how potential incidents identified at the installation together with their consequences should be dealt with, both on site and off site.
<b>ESD</b>	<b>Emergency Shutdown System (ESD)</b> is designed to minimize the consequences of emergency situations, related to typically uncontrolled flooding, escape of hydrocarbons, or outbreak of fire in hydrocarbon carrying areas or areas which may otherwise be hazardous.
<b>Explosion</b>	An <b>explosion</b> is a release of energy that causes a pressure discontinuity or blast wave.
<b>Flammable Limits</b>	<b>Flammable limits</b> are a range of gas or vapour concentrations in the air that will burn or explode if a flame or other ignition source is present. The lower point of the range is called the lower flammable limit (LFL).

	Likewise, the upper point of the range is called the upper flammable limit (UFL).
<b>Flammable Liquid</b>	<p>The Occupational Health and Safety Act 85 of 1993 defines a <b>flammable liquid</b> as any liquid which produces a vapour that forms an explosive mixture with air and includes any liquid with a closed cup flashpoint of less than 55°C.</p> <p>Flammable products have been classified according to their flashpoints and boiling points, which ultimately determine the propensity to ignite. Separation distances described in the various codes are dependent on the flammability classification.</p> <p><b>Class Description</b></p> <p>0 Liquefied petroleum gas (LPG)</p> <p>IA Liquids that have a closed cup flashpoint of below 23°C and a boiling point below 35°C</p> <p>IB Liquids that have a closed cup flashpoint of below 23°C and a boiling point of 35°C or above</p> <p>IC Liquids that have a closed cup flashpoint of 23°C and above but below 38°C</p> <p>II Liquids that have a closed cup flashpoint of 38°C and above but below 60.5°C</p> <p>IIA Liquids that have a closed cup flashpoint of 60.5°C and above but below 93°C</p>
<b>Flash Fire</b>	A <b>flash fire</b> is defined as combustion of a flammable vapour and air mixture in which the flame passes through the mixture at a rate less than sonic velocity so that negligible damaging overpressure is generated.
<b>FMEA</b>	Failure mode and effects analysis is the process of reviewing as many components, assemblies, and subsystems as possible to identify potential failure modes in a system and their causes and effects
<b>Frequency</b>	<b>Frequency</b> is the number of times an outcome is expected to occur in a given period of time.
<b>HAZOP</b>	A <b>hazard and operability study (HAZOP)</b> are a structured and systematic examination of a complex planned or existing process or operation in order to identify and evaluate problems that may represent risks to personnel or equipment.
<b>HEL</b>	The <b>highest</b> concentration of a gas or vapor (percentage by volume in air) above which a flame will not spread in the presence of an ignition source (arc, flame, or heat). Concentrations higher than UEL are "too rich" to burn. Also called upper flammable limit (UFL).
<b>Ignition Source</b>	An <b>ignition source</b> is a source of temperature and energy sufficient to initiate combustion.
<b>Individual Risk</b>	<b>Individual risk</b> is the probability that in one year a person will become a victim of an accident if the person remains permanently and unprotected in a certain location. Often the probability of occurrence in one year is replaced by the frequency of occurrence per year.
<b>Isopleth</b>	See <b>Risk Isopleth</b>
<b>Jet</b>	A <b>jet</b> is the outflow of material emerging from an orifice with significant momentum.
<b>Jet Fire or Flame</b>	A <b>jet fire or flame</b> is combusting material emerging from an orifice with a significant momentum.
<b>K&amp;T</b>	<b>Kantey &amp; Templer</b> are Consulting Engineers that convert engineering concepts into reality. They provide professional, quality engineering

	expertise to Africa.
<b>LEL</b>	The <b>Lower Explosive Limit (LEL)</b> is the lowest concentration of a gas or vapour that will burn in air. The Lower Explosive Limit (LEL) varies from gas to gas, but for most flammable gases it is less than 5% by volume.
<b>LFL</b>	<b>Lower Flammable Limit</b> see Flammable Limits
<b>LOC</b>	See <b>Loss of Containment</b>
<b>Local Government</b>	<b>Local government</b> is defined in Section 1 of the Local Government Transition Act, 1993 (Act No. 209 of 1993).
<b>Loss of Containment</b>	<b>Loss of containment (LOC)</b> is the event resulting in a release of material into the atmosphere.
<b>Major Hazard Installation</b>	<b>Major Hazard Installation (MHI)</b> means an installation: <ul style="list-style-type: none"> <li>• Where more than the prescribed quantity of any substance is or may be kept, whether permanently or temporarily;</li> <li>• Where any substance is produced, used, handled or stored in such a form and quantity that it has the potential to cause a major incident (the potential of which will be determined by the risk assessment).</li> </ul>
<b>Major Incident</b>	A <b>major incident</b> is an occurrence of catastrophic proportions, resulting from the use of plant or machinery or from activities at a workplace. When the outcome of a risk assessment indicates that there is a possibility that the public will be involved in an incident, then the incident is catastrophic.
<b>Material Safety Data Sheet</b>	According to ISO-11014, a <b>material safety data sheet (MSDS)</b> is a document that contains information on the potential health effects of exposure to chemicals or other potentially dangerous substances and on safe working procedures when handling chemical products. It is an essential starting point for the development of a complete health and safety program. It contains hazard evaluations on the use, storage, handling and emergency procedures related to that material. An MSDS contains much more information about the material than the label and it is prepared by the supplier. It is intended to tell what the hazards of the product are, how to use the product safely, what to expect if the recommendations are not followed, what to do if accidents occur, how to recognize symptoms of overexposure and what to do if such incidents occur.
<b>MEGC</b>	<b>Multiple Element Gas Containers</b> is multimodal assemblies of cylinders, tubes, and bundles of cylinders, which are interconnected by a manifold and assembled within a framework. The MEGC includes service equipment and structural equipment necessary for the transport of gases.
<b>MHI</b>	See <b>Major Hazard Installation</b>
<b>MIR</b>	<b>Maximum Individual Risk</b> (see Individual Risk)
<b>MSDS</b>	See <b>Material Safety Data Sheet</b>
<b>NEMA</b>	107 of 1998, abbreviated <b>NEMA</b> ) is the statutory framework to enforce Section 24 of the Constitution of the Republic of <b>South Africa</b> . The <b>NEMA</b> is intended to promote co-operative governance and ensure that the rights of people are upheld, but also recognising the necessity of economic development.
<b>OHS Act</b>	<b>Occupational Health and Safety Act</b> , 1993 (Act No. 85 of 1993)
<b>PADHI</b>	<b>PADHI (planning advice for developments near hazardous installations)</b> is the name given to a methodology and software decision

	<p>support tool developed and used in the HSE. It is used to give land-use planning (LUP) advice on proposed developments near hazardous installations.</p> <p>PADHI uses two inputs into a decision matrix to generate either an 'advise against' or 'don't advise against' response:</p> <ul style="list-style-type: none"> <li>• The zone in which the development is located of the three zones that HSE sets around the major hazard: <ul style="list-style-type: none"> <li>○ The inner zone (<math>&gt; 1 \times 10^{-5}</math> fatalities per person per year);</li> <li>○ The middle zone (<math>1 \times 10^{-5}</math> fatalities per person per year to <math>1 \times 10^{-6}</math> fatalities per person per year);</li> <li>○ The outer zone (<math>1 \times 10^{-6}</math> fatalities per person per year to <math>3 \times 10^{-7}</math> fatalities per person per year);</li> </ul> </li> <li>• The 'sensitivity level' of the proposed development which is derived from an HSE categorisation system of 'development types' (see the 'development type tables' in Appendix B).</li> </ul>
<b>PHA</b>	A <b>Process Hazard Analysis (PHA)</b> is directed toward analysing potential causes and consequences of fires, explosions, releases of toxic or flammable chemicals and major spills of hazardous chemicals, and it focuses on equipment, instrumentation, utilities, human actions, and external factors that might impact the process.
<b>POST</b>	The <b>Parliamentary Office of Science and Technology</b> is the Parliament of the United Kingdom's in-house source of independent, balanced and accessible analysis of public policy issues related to science and technology.
<b>PPE</b>	<b>Personal protective equipment</b> , commonly referred to as "PPE", is equipment worn to minimize exposure to hazards that cause serious workplace injuries and illnesses.
<b>QRA</b>	See <b>Quantitative Risk Assessment</b>
<b>Quantitative Risk Assessment</b>	A <b>quantitative risk assessment</b> is the process of hazard identification, followed by a numerical evaluation of effects of incidents, both consequences and probabilities and their combination into the overall measure of risk.
<b>Risk</b>	<b>Risk</b> is the measure of the consequence of a hazard and the frequency at which it is likely to occur. Risk is expressed mathematically as: <b>Risk = Consequence x Frequency of Occurrence</b>
<b>Risk Assessment</b>	<b>Risk assessment</b> is the process of collecting, organising, analysing, interpreting, communicating and implementing information in order to identify the probable frequency, magnitude and nature of any major incident which could occur at a major hazard installation and the measures required to remove, reduce or control potential causes of such an incident.
<b>Risk Contour</b>	See <b>Risk Isopleth</b>
<b>SANAS</b>	The <b>South African National Accreditation System (SANAS)</b> is the only national body responsible for carrying out accreditations in respect of conformity assessment, as mandated through the Accreditation for Conformity Assessment, Calibration and Good Laboratory Practice Act (Act 19 of 2006).
<b>Societal Risk</b>	<b>Societal risk</b> is risk posed on a societal group who are exposed to a hazardous activity.
<b>TNT</b>	<b>Trinitrotoluene</b> , more commonly known as TNT, and by its preferred

	IUPAC name 2-methyl-1,3,5-trinitrobenzene, is a chemical compound with the formula $C_6H_2(NO_2)_3CH_3$ . TNT is occasionally used as a reagent in chemical synthesis, but it is best known as an explosive material with convenient handling properties.
<b>UFL</b>	<b>Upper Flammable Limit</b> (see Flammable Limits)
<b>Vapour Cloud Explosion</b>	A <b>vapour cloud explosion</b> (VCE) results from ignition of a premixed cloud of a flammable vapour, gas or spray with air, in which flames accelerate to sufficiently high velocities to produce significant overpressure.
<b>VCE</b>	See <b>Vapour Cloud Explosion</b>

**12      APPENDIX A:      MHI REGULATIONS (2022)**



# Government Gazette Staatskoerant

REPUBLIC OF SOUTH AFRICA  
REPUBLIEK VAN SUID AFRIKA

*Regulation Gazette*

**No. 11536**

*Regulasiekoerant*

Vol. 691

31

January  
Januarie

2023

No. 47970



N.B. The Government Printing Works will not be held responsible for the quality of "Hard Copies" or "Electronic Files" submitted for publication purposes

ISSN 1682-5845



9 771682 584003

**AIDS HELPLINE: 0800-0123-22 Prevention is the cure**



**IMPORTANT NOTICE:**

**THE GOVERNMENT PRINTING WORKS WILL NOT BE HELD RESPONSIBLE FOR ANY ERRORS THAT MIGHT OCCUR DUE TO THE SUBMISSION OF INCOMPLETE / INCORRECT / ILLEGIBLE COPY.**

**No FUTURE QUERIES WILL BE HANDLED IN CONNECTION WITH THE ABOVE.**

**Contents**

<i>No.</i>		<i>Gazette No.</i>	<i>Page No.</i>
<b>GOVERNMENT NOTICES • GOEWERMENTSKENNISGEWINGS</b>			
<b>Employment and Labour, Department of / Indiensneming en Arbeid, Departement van</b>			
R. 2989	Occupational Health and Safety Act, 1993, as amended: Promulgation of Major Hazard Installation Regulations, 2022.....	47970	3

**GOVERNMENT NOTICES • GOEWERMENTSKENNISGEWINGS****DEPARTMENT OF EMPLOYMENT AND LABOUR**

NO. R. 2989

31 January 2023

**OCCUPATIONAL HEALTH AND SAFETY ACT (ACT No. 85 OF 1993), as  
amended****PROMULGATION OF MAJOR HAZARD INSTALLATION REGULATIONS, 2022**

I, Thembelani Waltermade Nxesi, Minister of Employment and Labour, hereto, after consultation with the Advisory Council of Occupational Health and Safety, promulgates the new regulation relating to Major Hazard Installations; in terms of section 43(1)(c) of the Occupational Health and Safety Act, 1993 (Act no. 85 of 1993).

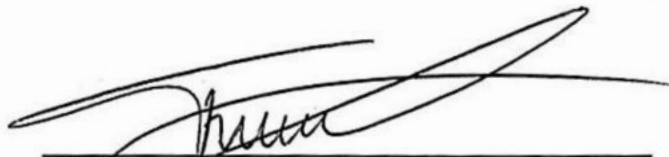

**MR TW NXESI, MP  
MINISTER OF EMPLOYMENT AND LABOUR  
DATE: 13/1/2022**

**OCCUPATIONAL HEALTH AND SAFETY ACT, 1993**  
**MAJOR HAZARD INSTALLATION REGULATIONS 20XX**

The Minister of Employment and Labour intends, after consultation with the Advisory Council for Occupational Health and Safety, in terms of section 43 of the Occupational Health and Safety Act, 1993 (Act No. 85 of 1993), to make the Regulations in the Schedule.

## SCHEDULE

### Definitions

1. In these Regulations, a word or expression to which a meaning has been assigned in the Act has the meaning so assigned and, unless the context otherwise indicates—

**"affected or interested party"** means a person, group of persons or organisations interested in or affected by an establishment and an organ of state that has jurisdiction over an establishment;

**"change"** means—

- (a) a modification in the methods, equipment or procedures in use or the handling or processing of dangerous substances in the establishment that may increase the establishment's risk profile;
- (b) an increase or decrease in the quantity of dangerous substances contemplated in Chapters 1 and 2 that results in the establishment being classified as a major hazard installation where—
  - (i) a low hazard establishment becomes a medium hazard establishment or vice versa;
  - (ii) a medium hazard establishment becomes a high hazard establishment or vice versa;
  - (iii) a low hazard establishment becomes a high hazard establishment or vice versa; or
  - (iv) an installation below the low hazard establishment threshold becomes a low, medium or high hazard establishment;
- (c) when an emergency plan is brought into action for a major incident;

**"dangerous substances"** means substances or mixtures used or present at the workplace that could, if not properly controlled, cause harm to people, the environment and property as a result of loss of containment, fire or explosion;

**"direction"** means a notice, or a recommendation or instruction served by an inspector in writing;

**"duty holder"** means an employer, a self-employed person, a user or a pipeline operator who is in control of an establishment;

**"establishment"** means a major hazard installation under the control of a duty holder where Chapter 1, 2 or 3 dangerous substances are present;

**"emergency plan"** means a plan contemplated in regulation 15;

**"existing establishment"** means an establishment where dangerous substances are present in quantities listed in Chapter 1, 2 or 3;

**"high hazard establishment"** means—

- (a) an establishment where Chapter 1 or 2 dangerous substances are present in quantities equal to or in excess of the quantities listed in column 3 of Chapter 1 or 2; and
- (b) pipelines contemplated in Chapter 3;

**"impact zone"** means the zone where other installations or neighbours could be affected due to a major incident;

**"installation"** means a technical unit within an establishment, above or below ground level, in which substances are produced, used and stored and which includes all the equipment, structures, pipework, machinery, tools, railway sidings and quays, warehouses and similar structures necessary for the operation of that installation;

**"low hazard establishment"** means an establishment where Chapter 1 or 2 dangerous substances are present and the quantity is equal to or exceeds the quantity in column 1 but is less than quantities listed in column 2 of Chapter 1 or 2;

**"licence to operate"** means a licence contemplated in regulation 13;

**"major incident prevention policy"** means a policy contemplated in regulation 11;

**"medium hazard establishment"** means an establishment where Chapter 1 or 2 dangerous substances are present and the quantity is equal to or exceeds the quantity in column 2, but is less than the quantity in column 3 of Chapter 1 or 2;

**"near miss"** means an event (causing damage to property, a negative impact on the environment or loss of human life) or operational interruption that could plausibly have resulted if the circumstances had been slightly different;

**"new establishment"** means an establishment which, after the date of entry into force of these Regulations, is erected or declared to be an establishment;

**"prescribed quantity"**, in relation to a given dangerous substance or a category or categories, means a quantity equal to the value set out in Annexure A;

**"process safety management system"** means a system contemplated in regulation 11(3)(h);

**"responsible person"** means a person designated, in writing, by a duty holder to be responsible, in a full-time capacity, for the premises on which an establishment is operated;

**"risk assessment"** means the process contemplated in regulation 10;

**"the Act"** means the Occupational Health and Safety Act, 1993 (Act No. 85 of 1993);

**"transit"** means a time or place in which dangerous substances are transported by rail, road, waterways or airways, which may be between planned points of departure and arrival;

**"Safety Data Sheet"** means a document aligned to globally harmonised systems, that provides information on the hazard classification, properties of hazardous chemicals and procedures for the handling of, or working with, hazardous chemicals in a safe manner and how hazardous chemicals affect health and safety in the workplace;

**"safety report"** means a report contemplated in regulation 12;

**"SANS 1461"** means South African National Standard: Major Hazard Installation – Risk Assessments, as amended from time to time;

**"SANS 1514"** means South African National Standard: Major Hazard Installation: Emergency Response Planning, as amended from time to time;

**"UN number"** means the dangerous substance four-figure identification number in the United Nations Transport of Dangerous Goods – Model Regulations, as amended from time to time;

**"UN Trough Test"** means Part III of the United Nations classification procedures, tests methods and criteria relating to class 2, class 3 and class 4, division 5.1, class 8 and class 9, as amended from time to time;

**"United Nations Recommendations on the Transport of Dangerous Goods"** means guidance documents developed by the United Nations to harmonise dangerous goods transport regulations, as amended from time to time, commonly known as the UN Orange Book.

### **Scope of application**

2. (1) These Regulations apply to—
  - (a) major hazard installations;
  - (b) establishments with the prescribed quantity of substances listed in Chapter 1 or 2; and
  - (c) major pipeline establishments.
- (2) These Regulations, excluding regulations 11, 12 and 13, apply to low hazard establishments.

- (3) These Regulations, excluding regulations 12 and 13, apply to medium hazard establishments.
- (4) Regulations 14 and 15 apply to local government.
- (5) Regulations 21 and 22 apply to an approved inspection authority.
- (6) These Regulations do not apply to nuclear installations registered in terms of the Nuclear Energy Act, 1993 (Act No. 131 of 1993).

### **Management of establishment**

3. (1) In order to ensure that the provisions of the Act and these Regulations in relation to major hazard installation are complied with, the duty holder must designate a responsible person in writing and in full-time capacity in respect of every premises where an establishment is operated.
- (2) Subject to subregulation (1), the chief inspector may require that any high hazard establishment be operated by a designated responsible person who holds a relevant qualification.
- (3) A duty holder may appoint, in writing, one or more deputies to assist the responsible person designated in terms of subregulation (1), and must clearly define the duties of such deputies without exempting the responsible person designated in subregulation (1) to properly discharge their duties.
- (4) If, in the opinion of the chief inspector, circumstances require the appointment of one or more deputies as contemplated in subregulation (3), the chief inspector may instruct the duty holder to appoint a specified number of deputies.
- (5) Every duty holder must on a regular basis consult with the neighbouring establishments and counterparts within the potential impact zone—
  - (a) to discuss any associated major incident associated with the type of establishment;
  - (b) to share any changes made to the establishment that alters the risk profile; and
  - (c) to share alert systems in a case of emergency.
- (6) The duty holder must keep a record of all consultations contemplated in subregulation (5).

### **Notification of establishment**

4. (1) A duty holder must notify the chief inspector, the relevant chief director: provincial operations and the local government on Form A, 90 days–
- (a) before the erection of an establishment; or
  - (b) when there is an anticipated change to an existing establishment.
- (2) A duty holder, after the entry into force of these Regulations, must update the notification of an existing establishment and send it to the chief inspector, the relevant chief director: provincial operations and the local government on a prescribed form A, within 24 months.
- (3) The notification referred to in subregulation (1) or (2) must be accompanied by–
- (a) proof of permission or approval from the relevant local government on land use indicating the exact location of the site;
  - (b) a letter of designation contemplated in regulation 3(2) and the responsible person's competency profile;
  - (c) an inventory list and safety data sheets of all the dangerous substances that resulted in the installation being classified as an establishment;
  - (d) a statement containing the envisaged maximum quantity of all the substances that may be present at the establishment at any one time;
  - (e) the most recent risk assessment report contemplated in regulation 10;
  - (f) a site map showing the establishment location and indicating developments around the vicinity of the establishment;
  - (g) a substance location plan drawn to a scale of not less than 1 to 2 500 which identifies the area on the site where the dangerous substances will be stored, handled, used or processed, showing the location of the major items of plant used in such activities;
  - (h) information regarding the neighbours or other establishments within the impact zone, including–
    - (i) sites that are likely to be affected by a major incident and their exact distances from the establishment;
    - (ii) known future development that might increase the risk or consequences of a major incident; and
    - (iii) other establishments and their exact distances;
  - (i) proof of the publication of the advertisement contemplated in subregulation (4); and



- (j) where applicable, the latest version of the major incident prevention policy.
- (4) A duty holder who erects an establishment or updates a risk assessment or converts an existing installation into an establishment must—
  - (a) place an advertisement, in English and the predominant language in the area, in at least one newspaper serving the communities in the vicinity of the establishment; and
  - (b) post notices within those communities, containing at least the—
    - (i) name and location of the establishment;
    - (ii) name, title and telephone number of the contact person from whom further information can be obtained;
    - (iii) nature of the dangerous substances and the major incidents that may occur; and
    - (iv) time and place where a risk assessment report will be explained and may be viewed.
- (5) Any affected or interested party may make representations, in writing, to the relevant local government and the chief inspector, within 60 days after the publication of an advertisement referred to in subregulation (4), if the establishment is not acceptable and poses a risk to that party.

### **Registration of establishment**

- 5.** (1) After considering the notification referred to in regulation 4(1) or (2), the chief inspector may on payment of the appropriate registration fee specified in Annexure B—
- (a) register the premises as a major hazard installation subject to such conditions as the chief inspector deems fit to impose;
  - (b) enter into the register, particulars pertaining to the name of the major hazard installation, the premises address and other details as the chief inspector deems fit; and
  - (c) issue to the duty holder a certificate of registration within 60 days; or
  - (d) refuse to register the major hazard installation.
- (2) Where the chief inspector refuses to register the major hazard installation in respect of which a notification has been made, the chief inspector must notify the duty holder of the reasons for the refusal.

(3) The duty holder must conspicuously display the latest registration certificate received in terms of subregulation (1)(c).

#### **Duration of registration and renewal**

6. (1) Subject to regulation 5(1), the registration is valid for a period of five years or for such other period as the chief inspector may determine in a particular case, unless the registration is earlier suspended or revoked in accordance with the Regulations.

(2) The chief inspector shall renew the registration upon the updating of a risk assessment and documents as may be required and on payment of the appropriate renewal fee specified.

#### **Alteration to particulars of registered establishment**

7. The duty holder must, where there is an alteration in any of the particulars of a major hazard installation, furnish the alterations to the chief inspector, relevant chief director: provincial operations and relevant local government not later than 14 days after such alteration occurs.

#### **Revocation or suspension of registration**

8. (1) The inspector may issue a direction instructing the duty holder immediately to comply with the requirements specified in the direction, if the premises of the registered major hazard installation become unfit for occupation or use because of a–

- (a) failure by the duty holder to ensure that work is carried out safely; or
- (b) change effected on the establishment without notifying the chief inspector, the chief director: provincial operations and the local government; or
- (c) new hazardous fact or circumstance that was not present when the establishment was registered.

(2) The chief inspector may revoke the registration if–

- (a) the duty holder fails to comply with the issued direction;
- (b) the chief inspector has established that the duty holder has contravened a condition of registration; or
- (c) the inspector has proven that the duty holder has ceased occupation or use of the premises as an establishment.

- (3) An inspector must, before advising the chief inspector to revoke or suspend the registration of an establishment as contemplated in subregulations (2) and (3)–
- (a) issue to the duty holder a direction, in writing, of the intention to revoke or suspend the registration; and
  - (b) give the duty holder a reasonable opportunity to submit reasons as to why the registration should not be revoked or suspended.
- (4) The revocation or suspension of registration does not take effect–
- (a) until the expiration of 21 days after the date on which direction of the chief inspector's intention to revoke or suspend the registration was given to the duty holder as contemplated in subregulation (4)(a); or
  - (b) where an appeal against the decision of the chief inspector is made to the Labour Court in terms of section 35 of the Act, until the appeal has been determined or withdrawn.
- (5) An inspector may advise the chief inspector at any time, and for a valid reason, to shorten the period for which the registration is suspended.

### **Sharing of information with adjacent establishments**

9. The chief inspector may designate one or more registered major hazard installations in a certain location as a group of establishments, and require such establishments to share information, including the–

- (a) basic particulars of the establishment;
- (b) responsible person for that establishment;
- (c) description of major incidents associated with that type of establishment, and consequences of such incidents; and
- (d) information on how affected neighbours will be alerted in the event of a major incident.

### **Risk assessment**

10. (1) A duty holder must, after consultation with the relevant health and safety representative or health and safety committee, ensure that an approved inspection authority carries out a risk assessment in accordance with SANS 1461 at intervals not exceeding five years or when there is a change in the establishment.

- (2) Every duty holder must–

- (a) inform the relevant health and safety representative or health and safety committee, in writing, of the arrangements made to carry out a risk assessment contemplated in subregulation (1); and
  - (b) ensure that the results of the risk assessment are made available to the relevant health and safety representative or committee, who may comment thereon.
- (3) Where a risk assessment has been reviewed or revised, without a change to the establishment, the duty holder must submit an updated copy of the risk assessment report to the chief inspector, the relevant chief director: provincial operations and the relevant local government within 60 days.
- (4) Every duty holder must ensure that a copy of the most recent risk assessment report is available on site for inspection by an inspector or a local government.
- (5) Subregulation (1) shall not apply in the case of rolling stock in transit: Provided that the operator of a railway shall ensure—
- (a) that a risk assessment applicable to rolling stock in transit is carried out and made available for inspection at the request of an inspector or a local government or both that inspector and that local government, as the case may be; and
  - (b) that, in the interest of the health and safety of the public, the necessary precautions are taken.
- (6) A duty holder shall ensure that the risk assessments contemplated in subregulations (1) and (3) be made available for scrutiny by any affected or interested person that may be affected by the activities of the establishment, at a time and place and in a manner agreed upon between the parties.

### **Major incident prevention policy**

11. (1) The duty holder must prepare and retain a written major incident prevention policy, as contemplated in Annexure C, on the—
- (a) construction and building of the establishment;
  - (b) change in the establishment; or
  - (c) safe operation of the establishment.
- (2) Every duty holder must, within 36 months after the entry into force of these Regulations, establish and have in record a major incident prevention policy.
- (3) The major incident prevention policy must provide for a high level of protection for employees and the public and must include at least—

- (a) the aims and objectives of the policy;
  - (b) the roles and responsibilities of the establishment's management;
  - (c) process safety performance indicators;
  - (d) commitments towards the maintenance and continual improvement of the policy;
  - (e) the aims and objectives of the—
    - (i) emergency plan;
    - (ii) evacuation plan regarding the—
      - (aa) speedy evacuation of persons;
      - (bb) roll-call after evacuation; and
      - (cc) plant shut down;
  - (f) reasons for revision;
  - (g) mandatory agreements; and
  - (h) the process safety management system with principles specified in Annexure D.
- (4) A duty holder must review the major incident prevention policy, every five years or when there is a change in the establishment which renders the existing policy inadequate: Provided that an updated copy is available for inspection by an inspector and a local government.

### **Safety report**

- 12.** (1) The duty holder of a high hazard establishment must prepare a comprehensive, site-specific, safety report, which must be—
- (a) developed during the design phase and be continually updated until the start date of operations; and
  - (b) maintained for the duration of the life of the establishment.
- (2) The safety report must demonstrate a suitable and sufficiently documented plan to ensure—
- (a) that reliable built-in safety has been incorporated into the—
    - (i) design;
    - (ii) construction;
    - (iii) operation; and
    - (iv) maintenance of any equipment and infrastructure used in the establishment; and

- (b) the application of–
  - (i) the major incident prevention policy;
  - (ii) the process safety management system;
  - (iii) the organisational and necessary measures to prevent major incidents and to limit their consequences;
  - (iv) the on-site emergency plan.
- (3) The safety report must also contain information regarding an off-site emergency plan to take the necessary measures in the event of a major incident.
- (4) The duty holder of a proposed high hazard establishment must submit to the chief inspector a–
  - (a) preliminary safety report at the design stage of that establishment; and
  - (b) final safety report within a reasonable time before the establishment starts operations.
- (5) The duty holder must send a safety report to the chief inspector within 36 months after the entry into force of these Regulations.
- (6) Every duty holder must review the safety report–
  - (a) every five years;
  - (b) prior to any change to the establishment; or
  - (c) whenever there is a change in the process safety management system which could have significant repercussions with respect to the prevention of major incidents or the limitation of the consequences of major incidents:  
Provided that the updated copy of the safety report, revised under this subregulation, is sent to the chief inspector within 60 days.

### **Licence to operate**

- 13.** (1) A duty holder who operates a high hazard establishment must apply for a licence to operate such an establishment.
- (2) An existing duty holder must apply for a licence not later than 36 months after the entry into force of these Regulations.
- (3) The chief inspector, upon receipt of an application in terms of subregulations (1) and (2), with a written proof of occupancy from the local government, may–
  - (a) issue a licence;
  - (b) decide not to issue a licence and give reasons for the decision; or

- (c) issue a licence subject to any condition that the chief inspector deems reasonable and necessary.
- (4) A licence issued under subregulation (3)–
  - (a) may not be transferred to another establishment; and
  - (b) lapses after 12 months if the new installation has not started operations or the establishment has not been operated within 12 months after the issue of the licence.
- (5) The chief inspector may–
  - (a) suspend or withdraw a licence if the conditions subject to which the licence was issued are not complied with; or
  - (b) alter a condition in an existing licence after consultation with the duty holder and the relevant health and safety representative or the relevant health and safety committee.

#### **General duties of local government**

**14.** (1) Without derogating from the provisions of the National Building Regulations and Building Standards Act, 1977 (Act No. 103 of 1977), and the Spatial Planning and Land Use Management Act, 2013 (Act No. 16 of 2013), a local government must not permit the erection of a new establishment or the expansion of an establishment at a separation distance that poses an unacceptable risk in terms of the risk assessment contemplated in regulation 10.

- (2) The local government must–
  - (a) permit a new development only where there is a separation distance which will not pose an unacceptable risk in terms of the risk assessment contemplated in regulation 10; and
  - (b) prohibit any new property development adjacent to an establishment that will result in that new development being declared an establishment.
- (3) The relevant local government must give consent for the on-site emergency plan and participate in the annual emergency test drill as contemplated in regulation 15(4)(e).
- (4) Where a relevant local government does not have the facilities available to control a major incident or to comply with the requirements of these Regulations, that local government must make prior arrangements with a neighbouring local government, the relevant provincial government or the duty holder for assistance.

- (5) The relevant local government is responsible for the off-site emergency plan to be followed outside the premises of the establishment.
- (6) The relevant local government must prepare an off-site emergency plan in accordance with SANS 1514 and in consultation with the duty holder and interested or affected persons, within 24 months after the entry into force of these Regulations, and thereafter immediately for new establishments, and review the plan when there are significant changes to the hazard profile of the area.
- (7) The duty holder must, on written request by, and within the time limits imposed by the local government, furnish the local government with the necessary information needed to prepare the off-site emergency plan.

### **Emergency plan**

- 15.** (1) A duty holder must, immediately after submission of the notification contemplated in regulation 4, in consultation with the relevant health and safety representatives or health and safety committee, in writing, appoint an emergency coordinating team consisting of at least–
- (a) the responsible person contemplated in regulation 3(2); or
  - (b) a responsible person's deputy contemplated in regulation 3(3); and
  - (c) a representative from the health and safety committee.
- (2) The duty holder must develop and maintain an on-site emergency plan before the establishment commences operations in consultation with the emergency coordinating team and in accordance with SANS 1514.
- (3) The on-site emergency plan for an existing establishment must be aligned and updated to SANS 1514 within 12 months after the entry into force of these Regulations.
- (4) A duty holder must–
- (a) ensure that the manner in which employees, visitors and neighbours will be warned of major incidents is included in the plan;
  - (b) sign a copy of the on-site emergency plan in the presence of at least two witnesses who have knowledge in emergency planning and who must be satisfied with the content of the emergency plan and attest to the signature of the duty holder;
  - (c) obtain approval of the on-site emergency plan from the relevant local government;



- (d) ensure that the on-site emergency plan is readily available at all times for implementation and use;
  - (e) cause the on-site emergency plan to be tested or exercised in practice at least once a year and take the necessary steps to arrange for the local government to participate in such tests; and
  - (f) give an early warning to affected or interested parties in case a major incident is likely to go beyond the borders of the establishment.
- (5) The duty holder and the relevant local government must take reasonable steps to activate the on-site emergency plan in case of an incident which may result in–
- (a) a major incident; or
  - (b) an uncontrolled event which may reasonably be expected to lead to a major incident; or
  - (c) a near miss that could reasonably be expected to have resulted in a major incident.
- (6) The duty holder must review the on-site emergency plan at least once every three years and, if necessary, revise the plan.
- (7) The duty holder and the local government must jointly ensure that all first responders at the scene of a major incident have the necessary skill to deal with the dangerous substances and are dressed in the appropriate emergency personal protective equipment as required in their respective emergency plans.

### **Reporting of risk and emergency occurrences**

- 16.** (1) A duty holder must–
- (a) subject to regulation 8 of the General Administrative Regulations, published under Government Notice R. 929 in *Government Gazette* 25129 of 25 June 2003, within 48 hours, inform the chief inspector by means of telephone, facsimile or similar means of communication of–
    - (i) a major incident; or
    - (ii) an incident that brought the emergency plan into activation;
  - (b) investigate and submit a written preliminary incident report to the chief inspector within seven days after an emergency occurrence and a major incident;
  - (c) submit a final report as soon as reasonably practicable but not later than six months after the incident;

- (d) investigate and record all near misses in a register which must at all times be available for inspection by an inspector and the local government.
- (2) A duty holder must, in the case of an emerging major incident or an emergency occurrence that was or may have been caused by a dangerous substance, inform the supplier of that dangerous substance about the incident.

### **Information and training**

- 17.** (1) A duty holder must, after consultation with the relevant health and safety representative or health and safety committee, ensure that all employees are adequately trained with regard to–
- (a) the scope of these Regulations;
  - (b) the nature of the establishment;
  - (c) potential major hazards and associated major incidents;
  - (d) potential risks to health and safety caused by the identified major hazards;
  - (e) the practices and control procedures for a major incident;
  - (f) the content of the emergency plan and that visitors also are conversant with such content; and
  - (g) the safety protocols and measures to be followed on-site.
- (2) The duty holder must ensure that all trained employees undergo refresher training whenever there is a change in the establishment or when the risk assessment has been reviewed.
- (3) The duty holder must provide induction orientation about the kept substances, major hazard areas and actions to be followed in case of emergency to all mandatorys, visitors and any person who, in any manner, assists in carrying out or conducting allocated duties, before they enter the establishment.
- (4) The duty holder must ensure the induction orientation as contemplated in subregulation (3) is refreshed in the event of any change to an establishment which significantly alters the risk associated with the establishment: Provided that the induction training will be valid for periods not exceeding 12 months.

### **General duties of suppliers**

- 18.** (1) Every person that supplies a dangerous substance to an establishment must issue a safety data sheet that is supplied with the substance and must also provide basic information for training on the use and handling of the substance.

(2) On receipt of information contemplated in regulation 16(2), a supplier of a dangerous substance involved in an emerging major incident or potential major incident must inform all clients supplied with that substance of the emerging potential dangers surrounding the dangerous substance.

(3) A supplier must, in the event of a major incident with regard to the dangerous substance supplied, provide information and advice that must be readily available on a 24-hour basis to all duty holders, the relevant local government and any other body concerned.

### **Payable fees**

19. (1) A duty holder must pay a prescribed fee each time a notification, a renewal or a revision of a risk assessment is sent to the chief inspector: Provided that the chief inspector may grant an exemption from payment of such fees or may determine any other fee, if necessary.

(2) The chief inspector may waive but not refund the whole or any part of any fee paid or payable under these Regulations.

### **MHI Advisory Committee**

20. (1) The chief inspector may, with the approval of the Advisory Council for Occupational Health and Safety, establish an MHI Advisory Committee to advise on any matter related to major hazard installations, codes, standards and training requirements: Provided that any accredited or approved training must be in accordance with South African Qualifications Authority standards.

(2) The chief inspector shall appoint members of the MHI Advisory Committee for a period that he may determine at the time of appointment: Provided that the members are approved by the Advisory Council for Occupational Health and Safety.

(3) Any person affected by the decision of the MHI Advisory Committee may appeal to the chief inspector within 60 days of such decision becoming known and the chief inspector shall, after considering the grounds of the appeal and the MHI Advisory Committee's reasons for the decision, confirm or set aside or vary the decision or substitute such decision for any other decision which the MHI Advisory Committee in the chief inspector's opinion ought to have taken.

(4) Any person aggrieved by the decision taken by the chief inspector under subregulation (3) may, within 60 days after the chief inspector's decision, appeal against such decision to the Labour Court.

### **Approved inspection authorities**

**21.** (1) An inspection body accredited in terms of the Accreditation for Conformity Assessment, Calibration and Good Laboratory Practice Act, 2006 (Act No. 19 of 2006), or a foreign inspection body must apply for registration to the chief inspector on Form B.

(2) On receipt of the application contemplated in subregulation (1) the chief inspector must, subject to conditions if deemed necessary, approve the application.

(3) In the event of a dispute between an approved inspection authority (AIA) and a duty holder regarding a technical or safety matter, which cannot be reasonably resolved, the disputing parties may refer the case to the chief inspector in writing for arbitration, setting out the full details of the dispute.

(4) The chief inspector must, upon receiving a dispute contemplated in subregulation (3), appoint an arbitrator mutually agreed upon between the South African National Accreditation System and the parties.

(5) The dispute must be investigated and arbitrated within a maximum of 90 days after the submission of a request for arbitration.

(6) The chief inspector may at any time withdraw any approval granted to an approved inspection authority, subject to section 35 of the Act.

### **Duties of approved inspection authority**

**22.** (1) An approved inspection authority must ensure that the risk assessment contemplated in regulation 10 is carried out in terms of SANS 1461.

(2) An approved inspection authority must provide results on the classification and acceptability of risk, and make recommendations with regard to the following:

- (a) the suitability of the existing emergency procedures for the major risks identified;
- (b) any organisational measures that may be required;
- (c) risk reduction proposals; and
- (d) any other relevant matter.

(3) The approved inspection authority must, after each risk assessment, furnish the duty holder with the latest risk assessment report and attachments as required in terms of SANS 1461: Provided that such reports must be made available upon request by the chief inspector.

(4) An approved inspection authority must, on a monthly basis, submit a list of all major hazard installations assessed, to the chief inspector, in the form contemplated in Annexure E.

### Closure

**23.** A duty holder must notify the chief inspector, the relevant chief director: provincial operations and the local government in writing, not less than 60 days prior to the installation ceasing to be a major hazard installation.

### Offences and penalties

**24.** (1) A duty holder who contravenes any of the provisions of these Regulations commits an offence and is, on conviction, liable to a fine not exceeding R5 000 000 or to imprisonment for a period not exceeding 24 months.

(2) The maximum permissible fines that may be imposed for contravening the Regulations are set out in the table below:

PREVIOUS CONTRAVENTIONS	CONTRAVENTIONS OF REGULATIONS: 3(1), 4(1), 4(4), 6(3), 7, 10, 11(1), 12(1), 13(1), 15(2), 16, 20(6) and 22
No previous contraventions	R500 000
A previous contravention within 12 months	R1 000 000
A previous contravention in respect of the same contravention within three years	R2 500 000
Three previous contraventions in respect of the same provision within three years	R5 000 000

**Repeal of regulations**

25. The Major Hazard Installation Regulations, 2001, published in Government Notice No. R. 692 of 30 July 2001, are hereby repealed.

**Short title and commencement**

26. These Regulations are called the "Major Hazard Installation Regulations, 2022", and come into operation on a date determined by the Minister by notice in the *Government Gazette*.

## ANNEXURE A

### Dangerous substances to which these Regulations apply

This Annexure applies to the presence of dangerous substances at any establishment and determines the application of the relevant regulations in accordance with regulation 2(1). The quantities set relate to each establishment.

### Chapter 1

#### Named Dangerous Substances

Where a substance or group of substances listed in this Annexure also falls within Chapter 2 substances, the qualifying quantities set out in Chapter 1 must be used.

Named substances	UN NUMBER	Quantities in tonnes		
		Column 1 Low Hazard	Column 2 Medium Hazard	Column 3 High Hazard
Ammonia anhydrous	1005	15	50	200
Ammonium nitrate (as described in Note 3)	Fertiliser based 2067 2071	2 000	5 000	10 000
Ammonium nitrate (as described in Note 4 )		500	1 250	5 000
Ammonium nitrate (as described in Note 5 )		150	350	2 500
Ammonium nitrate (as described in Note 6)		4	10	50
Potassium nitrate (as described in Note 7)	1486	2 000	5 000	10 000
Potassium nitrate (as described in Note 8)	1488	500	1 250	5 000

Named substances	UN NUMBER	Quantities in tonnes		
		Column 1 Low Hazard	Column 2 Medium Hazard	Column 3 High Hazard
Arsenic pentoxide, arsenic (V) acid and/or salts	1559	1	1	2
Arsenic trioxide, arsenious (III) acid and/or salts	1561	0,1	0,1	0,1
Bromine	(l) 1701 (a)1744	5	20	100
Chlorine	1017	5	10	25
Nickel compounds in inhalable powder form (nickel monoxide, nickel dioxide, nickel sulphide, tri-nickel disulphide, di-nickel trioxide)	3089	1	1	1
Ethyleneimine	1185	5	10	20
Fluorine	1045	5	10	20
Formaldehyde (concentration $\geq$ 90%)	1198	2,5	5	50
Hydrogen	1049	2,5	5	50
Hydrogen chloride (liquefied gas)	1050	5	25	250
Hydrogen fluoride	1052	2,5	5	20
Lead alkyls	-	2,5	5	50
Liquefied extremely flammable gases (including LPG) and natural gas (whether liquefied or not)	1075	20	50	200
Acetylene	1001	2,5	5	50
Ethylene oxide	3089	2,5	5	50



Named substances	UN NUMBER	Quantities in tonnes		
		Column 1 Low Hazard	Column 2 Medium Hazard	Column 3 High Hazard
Propylene oxide	1280	2,5	5	50
Methanol	1230	50	500	5 000
4,4-Methylenebis (2-chloraniline) and/or salts, in powder form	3077	0,01	0,01	0,01
Methyl isocyanate	2480	0,15	0,15	0,15
Oxygen	(compressed) 1072 (refrigerated) 1073	50	200	2 000
Toluene di-isocyanate	2078	1	10	100
Carbonyl dichloride (phosgene)	1076	0,3	0,3	0,75
Arsenic trihydride (arsine)	2188	0,2	0,2	1
Phosphorus trihydride (phosphine)	2199	0,2	0,2	1
Sulphur dichloride	1828	1	1	1
Sulphur dioxide	1079	2,5	5	20
Sulphur trioxide	1829	7,5	15	75
Polychlorodibenzofurans and polychlorodibenzodioxins (including TCDD), calculated in TCDD equivalent (see Note 8)	-	0,001	0,001	0,001
The following CARCINOGENS at concentrations above 5% by weight:	-	0,5	0,5	2

Named substances	UN NUMBER	Quantities in tonnes		
		Column 1 Low Hazard	Column 2 Medium Hazard	Column 3 High Hazard
4-Aminobiphenyl and/or its salts, Benzotrichloride, Benzidine and/or salts, Bis (chloromethyl) ether, Chloromethyl methyl ether, 1,2-Dibromoethane, Diethyl sulphate, Dimethyl sulphate, Dimethylcarbamoyl chloride, 1,2-Dibromo-3-chloropropane, 1,2-Dimethylhydrazine, Dimethylnitrosamine, Hexamethylphosphoric triamide, Hydrazine, 2-Naphthylamine and/or salts, 4-Nitrodiphenyl and 1,3-Propanesultone				
Petroleum products: gasolines, naphthas, kerosenes (including jet fuels), gas oils (including diesel fuels, home heating oils and gas oil blending streams)	Gas (1075)  Crude (1275)	250	2 500	25 000
Boron trifluoride	1008	5	5	20
Hydrogen sulphide	1053	5	5	20
Piperidine	2401	20	50	200

Named substances	UN NUMBER	Quantities in tonnes		
		Column 1 Low Hazard	Column 2 Medium Hazard	Column 3 High Hazard
Bis(2-dimethylaminoethyl) (methyl)amine	-	20	50	200
3-(2-Ethylhexyloxy) propylamine	-	20	50	200
Propylamine	1277	200	500	2 000
Tert-butyl acrylate	-	100	200	500
2-Methyl-3-butenenitrile	-	200	500	2 000
Tetrahydro-3,5-dimethyl- 1,3,5-thiadiazine-2-thione (Dazomet)	1277	50	100	200
Methyl acrylate	1919	200	500	2 000
3-Methylpyridine	2313	200	500	2 000
1-Bromo-3-chloropropane	2688	200	500	2 000

## Chapter 2

### Categories of Dangerous Substances

This Chapter covers all dangerous substances falling under the hazard categories in column 1 in accordance with the GHS as reflected in the CLP Regulations:

Hazard categories	Column 1 Low Hazard	Column 2 Medium Hazard	Column 3 High Hazard
<b>1. Health Hazards: "H"</b>			
1.1 H1 Acute Toxic Category 1, all exposure routes	5	5	20
1.2 H2 Acute Toxic Category 2, all exposure routes Category 3, inhalation exposure route (see Note 9)	15	50	200
1.3 H3 Specific Target Organ Toxicity (STOT) Category 1, Single Exposure (SE STOT)	15	50	200
<b>2. Physical Hazards: "P"</b>			
2.1 P2 Flammable gases Flammable gases, Category 1 or 2	2,5	10	50
2.2 P3a Flammable aerosols (see Note 10) Flammable aerosols Category 1 or 2, containing flammable gases Category 1 or 2 or flammable liquids Category 1	50 (net)	150 (net)	500 (net)
2.3 P3b Flammable aerosols (see Note 11)	1 250 (net)	5 000 (net)	50 000 (net)

<b>Hazard categories</b>	<b>Column 1 Low Hazard</b>	<b>Column 2 Medium Hazard</b>	<b>Column 3 High Hazard</b>
Flammable aerosols Category 1 or 2, not containing flammable gases Category 1 or 2 nor flammable liquids category 1 (see Note 12)			
2.4 P4 Oxidising gases Oxidising gases, Category 1	20	50	200
P5a Flammable liquids Flammable liquids, Category 1 maintained at a temperature above their boiling point, or Flammable liquids Category 2 or 3 maintained at a temperature above their boiling point, or Other liquids with a flash point $\leq 60^{\circ}\text{C}$ , maintained at a temperature above their boiling point (see Note 12)	5	10	50
2.6 P5b Flammable liquids Flammable liquids Category 2 or 3 where particular processing conditions, such as high pressure or high temperature, may create major accident hazards, or Other liquids with a flash point $\leq 60^{\circ}\text{C}$ where particular processing conditions, such as high pressure or high temperature, may create major accident hazards (see Note 13)	20	50	200
2.6 P5c Flammable liquids Flammable liquids, Categories 2 or 3 not covered by P5a and P5b	1 250	5 000	50 000

<b>Hazard categories</b>	<b>Column 1 Low Hazard</b>	<b>Column 2 Medium Hazard</b>	<b>Column 3 High Hazard</b>
2.7 P6a Self-reactive substances and mixtures and organic peroxides Self-reactive substances and mixtures, Type A or B or organic peroxides, Type A or B	5	10	50
2.8 P6b Self-reactive substances and mixtures and organic peroxides Self-reactive substances and mixtures, Type C, D, E or F or organic peroxides, Type C, D, E or F	20	50	200
2.9 P7 Pyrophoric liquids and solids Pyrophoric liquids, Category 1 Pyrophoric solids, Category 1	20	50	200
2.10 P8 Oxidising liquids and solids Oxidising liquids, Category 1, 2 or 3, or Oxidising solids, Category 1, 2 or 3	20	50	200
<b>3. Other Hazards: "O"</b>			
3.1 O1 Substances or mixtures that react violently with water. Examples: acetyl chloride, alkali metals and titanium tetrachloride	40	100	500
3.2 O2 Substances and mixtures which in contact with water emit flammable gases, Category 1	40	100	500
3.3 O3 Substances or mixtures that liberate toxic gas when in contact with water.	20	50	200

Hazard categories	Column 1 Low Hazard	Column 2 Medium Hazard	Column 3 High Hazard
Examples: aluminium phosphide and phosphorus pentasulphide			

Net: indicates the flammable content and not the full gross mass, thus the mass of the containers is ignored.

### Chapter 3

#### Classification of pipelines as major hazard establishment

A pipeline is considered an establishment if it contains any of the following:

- (1) A fluid which—
  - (a) is flammable in air;
  - (b) has a boiling point below 5°C at 1 bar absolute; and
  - (c) is or is to be conveyed in a pipeline as a liquid.
- (2) A fluid which is or is to be conveyed in a pipeline as a gas which is—
  - (a) at pressures at above 8 bar absolute\*;
  - (b) flammable in air\*\*.
- (3) Pressurised substances:
  - (a) Mixtures of gas and liquid which have a vapour pressure in excess of 0,5 bar above atmospheric pressure when in equilibrium with its vapour included;
  - (b) A liquid which has a vapour pressure greater than 1,5 bar absolute when in equilibrium with its vapour at either the actual temperature of the liquid or at 20°C.
- (4) A very toxic fluid which—
  - (a) at 20°C has a saturated vapour pressure greater than 0,001 bar; or
  - (b) is or is to be conveyed in the pipeline as a liquid at a pressure greater than 4,5 bar absolute.
- (5) A very toxic or toxic fluid which—
  - (a) is a gas at 20°C and 1 bar absolute; and

- (b) is or is to be conveyed as a liquid or a gas, i.e. ammonia.
- (6) A toxic fluid which—
  - (a) at 20°C has a saturated vapour pressure greater than 0,4 bar; and
  - (b) is or is to be conveyed in the pipeline as a liquid.
- (7) An oxidising fluid which is or is to be conveyed as a liquid.
- (8) A fluid which reacts violently with water.
- (9) Acrylonitrile.
- (10) Carbon dioxide.
- (11) Gasoline. (Note14)

\* Paragraph 2(a) also covers liquefied gases which are flammable in air when they are conveyed as a liquid. This includes butane and propane when conveyed in a pipeline as a liquid.

\*\*Paragraph 2(b) is applicable to flammable gases conveyed as a gas. In such cases the additional duties only apply when the flammable gas is conveyed at a pressure in excess of 8 bars absolute. This covers such fluids as methane, butane and propane when conveyed as a gas.

## NOTES

- (1) The quantities set in Chapters 1 and 2 relate to each establishment.
- (2) Mixtures and preparations must be treated in the same way as pure substances, provided they remain within the concentration limits set according to their properties under the CLP Regulations (EC 1272\2008, as amended), unless a percentage composition or other description is specifically given.
- (3) Ammonium nitrate: fertilisers capable of *self-sustaining decomposition*.  
This applies to ammonium nitrate-based compound/composite fertilisers (compound or composite fertilisers containing ammonium nitrate with phosphate and/or potash) which are capable of self-sustaining decomposition according to UN Trough Test (Part III, subsection 38.2) and in which the nitrogen content as a result of ammonium nitrate is—
  - (a) between 15,75% and 24,5% by weight and either with not more than 0,4% total combustible or organic materials or which satisfies the



requirements of United Nations Recommendations on the Transport of Dangerous Goods: Manual of Tests and Criteria (3rd revised Edition, or as amended from time to time), Ammonium Nitrate Materials (High Nitrogen Content) Safety Regulations 2003, as amended, "the detonation resistance test"; or

(b) 15,75% or less by weight and unrestricted combustible materials.

(4) Ammonium nitrate: *fertiliser grade*.

This applies to straight ammonium nitrate-based fertilisers and to ammonium nitrate-based compound/composite fertilisers which satisfies the requirements of UN TDG and in which the nitrogen content as a result of ammonium nitrate is—

- (a) more than 24,5% by weight, except for mixtures of ammonium nitrate with dolomite, limestone and/or calcium carbonate with a purity of at least 90%;
- (b) more than 15,75% by weight for mixtures of ammonium nitrate and ammonium sulphate;
- (c) more than 28% by weight for mixtures of ammonium nitrate with dolomite, limestone and/or calcium carbonate with a purity of at least 90%, and which satisfy the detonation resistance test.

(5) Ammonium nitrate: *technical grade*.

This applies to—

- (a) ammonium nitrate and preparations of ammonium nitrate in which the nitrogen content as a result of the ammonium nitrate is—
    - (i) *between 24,5% and 28% by weight, and which contain not more than 0,4% combustible substances; or*
    - (ii) *more than 28% by weight, and which contain not more than 0,2% combustible substances;*
  - (b) aqueous ammonium nitrate solutions in which the concentration of ammonium nitrate is more than 80% by weight.
- (6) Ammonium nitrate (10/50): *"off-specs" material not satisfying the detonation test.*

This applies to—

- (a) material rejected during the manufacturing process and to ammonium nitrate and preparations of ammonium nitrate, straight ammonium nitrate-based fertilisers and ammonium nitrate-based compound/composite fertilisers referred to in Notes 2 and 3, that are

being or have been returned from the final user to a manufacturer, temporary storage or reprocessing plant for reworking, recycling or treatment for safe use, because they no longer comply with the specifications of Notes 4 and 5; or

- (b) fertilisers which do not fall within Notes 3(a) and 5 because they do not satisfy the detonation resistance test, other than fertilisers which—
- (i) *at the time of delivery to a final user satisfied the detonation resistance test; but*
  - (ii) *later became degraded or contaminated; and*
  - (iii) *are temporarily present at the establishment of the final user prior to their return for reworking, recycling or treatment for safe use or to their being applied as fertiliser.*

\*15,75% nitrogen content by weight as a result of ammonium nitrate corresponds to 45% ammonium nitrate.

\*\*24,5% nitrogen content by weight as a result of ammonium nitrate corresponds to 70% ammonium nitrate.

\*\*\*28% nitrogen content by weight as a result of ammonium nitrate corresponds to 80% ammonium nitrate.

- (7) Potassium nitrate:
- (a) Potassium nitrate (5 000/10 000): composite potassium nitrate-based fertilisers composed of potassium nitrate in prilled/granular form.
  - (b) Potassium nitrate (1 250/5 000): composite potassium nitrate-based fertilisers composed of potassium nitrate in crystalline form.
- (8) Polychlorodibenzofurans and polychlorodibenzodioxins. The quantities of polychlorodibenzofurans and polychlorodibenzodioxins are calculated using the following factors:

TABLE 8.1 ITEF

International Toxic Equivalent Factors (ITEF) for the congeners of concern (NATO/CCMS)*			
2, 3, 7, 8-TCDD	1	2, 3, 7, 8-TCDF	0,1
1, 2, 3, 7, 8-PeCDD	0,5	2, 3, 4, 7, 8-PeCDF	0,5
		1, 2, 3, 7, 8-PeCDF	0,05
1, 2, 3, 4, 7, 8-HxCDD	0,1		
1, 2, 3, 6, 7, 8-HxCDD	0,1	1, 2, 3, 4, 7, 8-HxCDF	0,1
1, 2, 3, 7, 8, 9-HxCDD	0,1	1, 2, 3, 7, 8, 9-HxCDF	0,1
		1, 2, 3, 6, 7, 8-HxCDF	0,1
1, 2, 3, 4, 6, 7, 8-HpCDD	0,01	2, 3, 4, 6, 7, 8-HxCDF	0,1
		1, 2, 3, 4, 6, 7, 8-HpCDF	0,01
OCDD	0,001	1, 2, 3, 4, 7, 8, 9-HpCDF	0,01
		OCDF	0,001

\* (T = tetra, Pe = penta, Hx = hexa, Hp = hepta, O = octa)

- (9) In a case where dangerous substances fall within category P5a flammable liquids or P5b flammable liquids, then for the purposes of these Regulations the lowest qualifying quantities apply.
- (10) Dangerous substances that fall within the Acute Toxic Category 3 via the oral route (H 301) fall under entry H2 Acute Toxic in those cases where neither acute inhalation toxicity classification nor acute dermal toxicity classification can be derived, for example, due to lack of conclusive inhalation and dermal toxicity data.
- (11) Flammable aerosols classified in accordance with the Classification and Labelling of Chemicals (GHS) classification criteria for substances and mixtures, physical hazards, and flammable gases and aerosols.
- (12) In order to use paragraph (11), the aerosol dispensers must not contain flammable gas Category 1 or 2 nor flammable liquid Category 1.
- (13) In accordance with CLP Regulation, the liquids with a flash point of more than 35°C need not be classified in Category 3 if negative results have been obtained in the sustained combustibility test L.2, Part III, section 32 of the UN

Manual of Tests Criteria. This is, however, not valid under elevated conditions such as high temperature or pressure and therefore such liquids are included in this categories.

- (14) "Gasoline" means any petroleum derivative, other than liquefied petroleum gas, with a flash point between  $-51^{\circ}\text{C}$  and  $-40^{\circ}\text{C}$  and which is suitable for use in motor vehicles.
- (15) The following examples are for illustrative purposes only and each situation should be considered carefully. In case of any doubt, the individual situation should be discussed with the approved inspection authority.
- (16) The substances present at an establishment only in quantities equal to or less than 2% of the relevant qualifying quantity must be ignored for the purposes of calculating the total quantity present if their location within an establishment is such that it cannot act as an initiator of a major incident elsewhere on site.

(16.1) **Application of the aggregation of substances**

**Example 1**

*A site with 4 tonnes of hydrogen (medium hazard threshold 5 tonnes) and 1 500 tonnes of flammable liquids meeting Category 6 of Chapter 3 of Annexure A (medium hazard threshold 5 000 tonnes).*

*The aggregation rule gives:  $(4/5) + (1\ 500/5\ 000) = 0,8 + 0,3 = 1,1$*

*As this result is greater than 1, medium hazard category applies.*

**Example 2**

*A site with 150 tonnes of toxic substances meeting Category 2 of Chapter 2 of Annexure A (high hazard threshold 200 tonnes) and 1 tonne of arsenic pentoxide (high hazard threshold 2 tonnes).*

*The aggregation rule gives:  $(150/200) + (1/2) = 0,75 + 0,5 = 1,25$*

*As this result is greater than 1, high hazard category applies.*

- (17) In the case of an establishment where no individual substance or preparation is present in a quantity above or equal to the relevant qualifying quantities, the following rules must be applied to determine if the establishment is covered by the relevant requirements of these Regulations:

(17.1) **Application of the aggregation of categories**

**1. High Hazard Category:**

If the sum -  $q_1/Q_{U1} + q_2/Q_{U2} + q_3/Q_{U3} + q_4/Q_{U4} + q_5/Q_{U5} + \dots$  is greater than or equal to 1, where—

- (a)  $q_x$  = the quantity of dangerous substance  $x$  (or category of dangerous substances) falling within Chapter 1 or 2; and
- (b)  $Q_{UX}$  = the relevant qualifying quantity for substance or category  $x$  from column 5 of Chapter 1 or 2, then these Regulations shall apply.

**2. Medium Hazard Category:**

If the sum -  $q_1/Q_{M1} + q_2/Q_{M2} + q_3/Q_{M3} + q_4/Q_{M4} + q_5/Q_{M5} + \dots$  is greater than or equal to 1, where—

- (a)  $q_x$  = the quantity of dangerous substance  $x$  (or category of dangerous substances) falling within Chapter 1 or 2; and
- (b)  $Q_{MX}$  = the relevant qualifying quantity for substance or category  $x$  from column 4 of Chapter 1 or 2, then these Regulations shall apply.

**3. Low Hazard Category:**

If the sum -  $q_1/Q_{L1} + q_2/Q_{L2} + q_3/Q_{L3} + q_4/Q_{L4} + q_5/Q_{L5} + \dots$  is greater than or equal to 1, where—

- (c)  $q_x$  = the quantity of dangerous substance  $x$  (or category of dangerous substances) falling within Chapter 1 or 2; and
- (d)  $Q_{LX}$  = the relevant qualifying quantity for substance or category  $x$  from column 3 of Chapter 1 or 2, then these Regulations shall apply.

- (18) These rules must be used to assess the overall hazards associated with toxicity, flammability and eco-toxicity. They must therefore be applied three times—

- (a) for the addition of substances and preparations named in Annexure A and classified as toxic or very toxic, together with substances and preparations falling into Category 1 or 2 in Chapter 2;
- (b) for the addition of substances and preparations named in Annexure A and classified as oxidising, explosive, flammable, highly flammable or extremely flammable, together with substances and preparations falling into Category 3, 6, 7a, 7b or 8 of Chapter 2; and
- (c) for the addition of substances and preparations named in Annexure A1 and classified as Annexure A for the environment (toxic to aquatic organisms), together with substances and preparations falling into Category 7(a) or 9(b) in Chapter 2, and the relevant provisions of these Regulations shall apply if any of the sums thereby obtained is greater than or equal to 1.

The relevant provisions of these Regulations apply where any of the sums obtained by (a), (b) or (c) is greater than or equal to 1, *stated in material safety data sheets of substances as per Dangerous Substances Directive (67/548/EEC)*.

#### (18.1) **Application of the 2% rule**

The 2% rule should be applied as follows:

1. The substances present at an establishment only in quantities equal to or less than 2% of the relevant qualifying quantity must be ignored for the purposes of calculating the total quantity present if their location within an establishment is such that it cannot act as an initiator of a major incident elsewhere on site.
2. This allows for some quantities of substances to be ignored when deciding whether the Regulations apply. Individual quantities of dangerous substances can be ignored if they fulfil the following criteria:
  - (a) *the quantity is 2% or less of its threshold quantity; and*
  - (b) *its location means that it cannot start a major incident elsewhere on site.*
3. *Note that–*
  - (a) *both criteria must be met;*
  - (b) *the quantity involved may be capable of producing a major incident by itself;*
  - (c) *it may be capable of starting a major incident off site; and*

- (d) *if it meets the criteria, it can be ignored only when determining whether the establishment is within the scope of these Regulations. If the establishment is subject to the Regulations because of the presence of other dangerous substances, any quantity of 2% or less must be taken into account when considering the sources and consequences of major incidents.*

The diagram below does not depict an approved installation but it is meant for illustrative purposes only.

### **Example 1**

*An establishment with—*

- (a) *a large tank containing 49,5 tonnes of LPG; and*  
(b) *a small tank containing 1,0 tonne of LPG.*

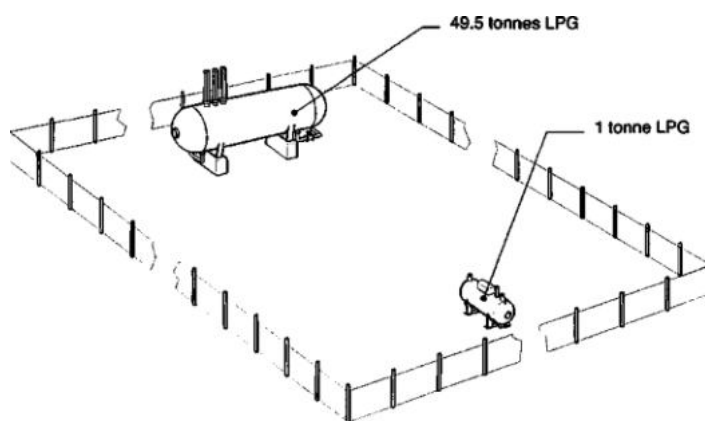

*The small tank = 2% of medium hazard threshold (50 tonnes), but the separation from the large tank is sufficient to prevent the small tank starting a major incident at the large tank. It can therefore be ignored in terms of the 2% rule.*

*The result is that medium hazard category does not apply, even though the total quantity of 50,5 tonnes is above the medium hazard threshold, which places it in the low hazard category.*

**Example 2**

An establishment with–

- (a) a large tank containing 49,5 tonnes of LPG; and
- (b) two small tanks each containing 1,0 tonne of LPG.

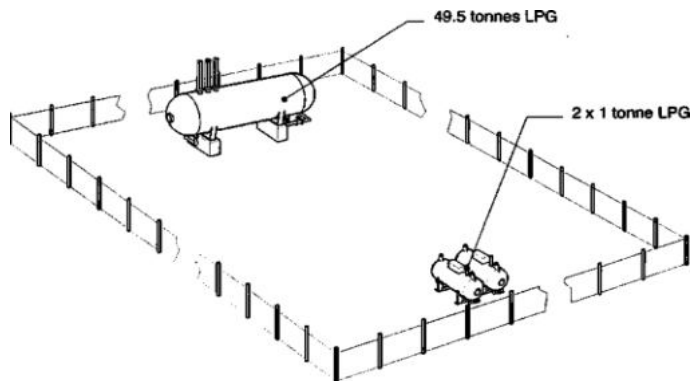

Each small tank = 2% of medium hazard threshold (50 tonnes), but their separation from the large tank and from each other is sufficient to prevent either of them starting a major incident at the other small tank or the large tank. Therefore, each can be ignored in terms of the 2% rule.

The result is that medium hazard category does not apply, even though the total quantity of 51,5 tonnes is above the medium hazard threshold, which places it in the low hazard category.

**Example 3**

An establishment with–

- (a) a large tank containing 49,5 tonnes of LPG; and
- (b) two small tanks each containing 1,0 tonne of LPG.

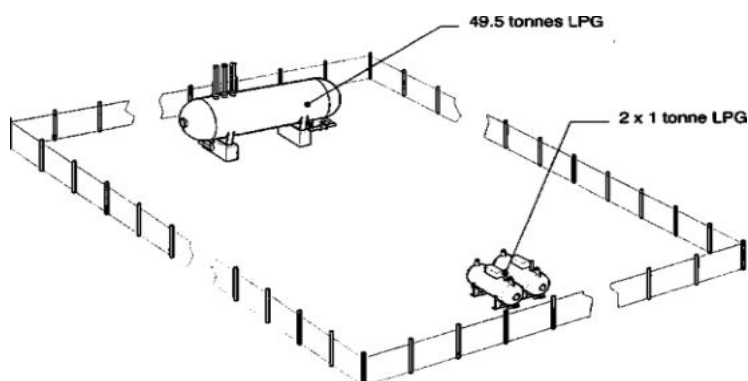



*The small tanks are adjacent to each other but their separation from the large tank is not sufficient to prevent the small tanks starting a major incident at the large tank.*

*Both small tanks = 2% of threshold (50 tonnes), but as they are adjacent they should be regarded as one quantity of more than 2%; therefore, the 2% rule does not apply. As the total quantity of 51,5 tonnes exceeds the medium hazard threshold, the medium hazard threshold applies to this establishment.*

#### **Example 4**

*An establishment with—*

- (a) a large tank containing 49,5 tonnes of LPG; and*
- (b) two small tanks each containing 0,5 tonnes of LPG.*

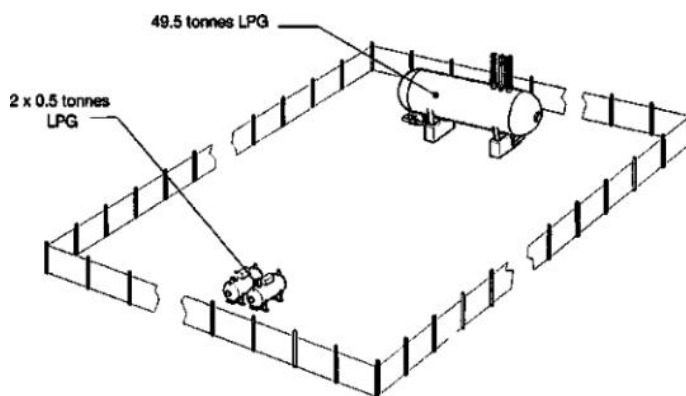

*The small tanks are adjacent to each other but well separated from the large tank.*

*Both small tanks = 1% of threshold (50 tonnes), but as they are adjacent they should be regarded as one quantity of 1 tonne which = 2%. As this cannot start a major incident elsewhere on site, the 2% rule applies and the medium hazard category does not apply even though the total quantity is greater than the medium hazard threshold, which places it in the low hazard category.*

#### **Example 5**

*An establishment with—*

- (a) a large tank containing 49,5 tonnes of LPG; and*
- (b) a compound containing 100 x 10 kg cylinders of LPG, i.e. 1 tonne in total.*

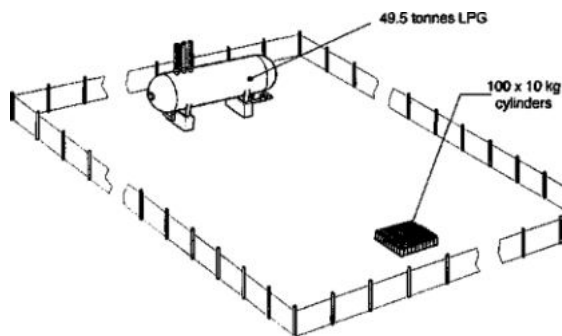

*The separation between the compound and the large tank is sufficient to prevent the cylinders starting a major incident at the large tank.*

*Each cylinder contains less than 2% of the medium hazard threshold (50 tonnes) and the total quantity in the cylinders is 1 tonne, which is 2% of the medium hazard threshold. The cylinder compound cannot start a major incident elsewhere on site, so the 2% rule applies. Therefore, the medium hazard category does not apply, which places it in the low hazard category.*

### **Example 6**

*An establishment with–*

- (a) a large tank containing 49,5 tonnes of LPG; and*
- (b) a compound containing 100 x 15 kg cylinders of LPG, i.e. 1,5 tonnes in total.*

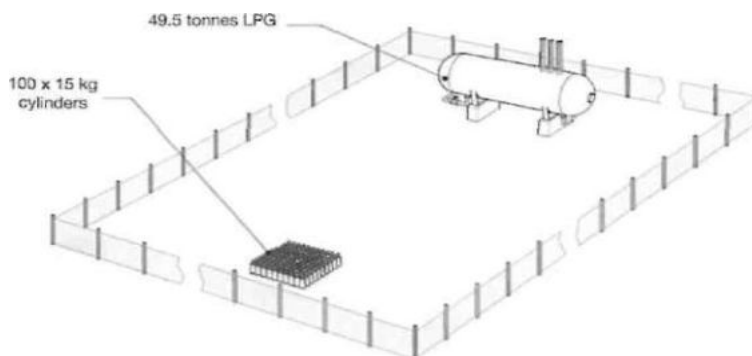

*The separation between the compound and the large tank is sufficient to prevent the cylinders starting a major incident at the large tank.*

Each cylinder contains less than 2% of the medium hazard threshold (50 tonnes) but as they are adjacent to each other they should be treated as one quantity of 1,5 tonnes, which is greater than 2% of the medium hazard threshold. Therefore, the medium hazard category applies to this establishment.

### Example 7

An establishment with—

- (a) a large tank containing 49,5 tonnes of LPG;
- (b) a tank containing 0,9 tonnes of highly flammable liquid (medium hazard threshold 50 tonnes); and
- (c) a tank containing 0,1 tonnes of extremely flammable liquid (medium hazard threshold 10 tonnes).

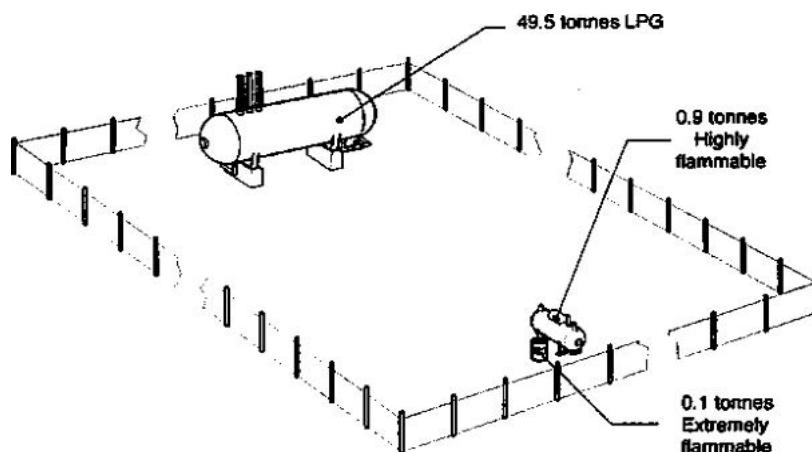

The small tanks are adjacent, but their separation from the large tank is enough to prevent the small tanks starting a major incident at the large tank. The total quantity for application purposes is determined by the aggregation rules, but first it is necessary to determine if the small tanks together exceed 2% of their threshold.

To do this, each one is expressed as a percentage of its own threshold and added together:

1. Small tanks

$(0,9/50) + (0,1/10) = 0,018 + 0,01 = 1,8\% + 1,0\% = 2,8\%$ . As this is greater than 2%, they cannot be ignored for application purposes.

The aggregation rule gives:

$$(49,5/50) + (0,9/50) + (0,1/10)$$

$$= 0,99 + 0,018 + 0,01$$

$$= 1,018$$

1,018 is greater than 1, so the medium hazard category applies to the establishment.

### Example 8

An establishment with—

- (a) a large tank containing 49,5 tonnes of LPG;
- (b) a tank containing 0,9 tonnes of highly flammable liquid (medium hazard threshold 50 tonnes); and
- (c) a tank containing 0,1 tonnes of extremely flammable liquid (medium hazard threshold 10 tonnes).

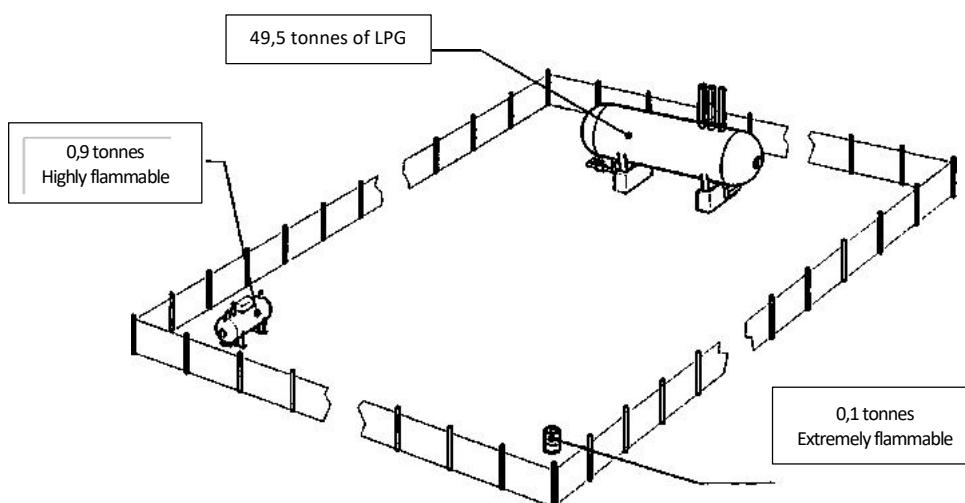

The separation is sufficient that neither small tank can start a major incident at either the other small tank or the large tank.

Because neither small tank exceeds 2% of its threshold, they can both be ignored for application purposes and the total quantity for application purposes is, therefore, the 49,5 tonnes of LPG. This is below its medium hazard threshold, so the medium hazard category does not apply to the establishment, which places it in the low hazard category.

**ANNEXURE B**

The fees for the registration and renewal of a certificate of registration are set out in the third and fourth columns of the table below:

CATEGORY OF MHI	CLASSES OF MHI	REGISTRATION FEE	RENEWAL FEE
Considered an MHI	-	R350	R350
Storage, use, handling, manufacturing and processing of one or more dangerous substances	LOW	R350	R350
	MEDIUM	R400	R400
	HIGH	R450	R450

**ANNEXURE C****Major Incident Prevention Policy**

The following principles should be taken into account when preparing a major incident prevention policy:

- (1) For the purpose of implementing the duty holder's major incident prevention policy and process safety management system, the following elements must be considered:
  - (a) the requirements laid down in the major incident prevention policy document must be proportionate to the hazards associated with major incidents present in the establishment;
  - (b) the major incident prevention policy must include the duty holder's aims and principles of action with respect to the control of hazards associated with major incidents.
  - (c) the process safety management system must include resources for determining and implementing the major incident prevention policy.
- (2) The following issues must be addressed by the process safety management system:
  - (a) organisation and personnel – the roles and responsibilities of personnel involved in the management of major hazards at all levels in the organisation. The identification of training needs of such personnel and

- the provision of the training so identified. The involvement of employees and, where appropriate, subcontractors;*
- (b) identification and evaluation of major hazards – adoption and implementation of procedures for systematically identifying major hazards arising from normal and abnormal operation and the assessment of their likelihood and severity;*
  - (c) operational control – adoption and implementation of procedures and instructions for safe operation, including maintenance of plant, processes, equipment and temporary stoppages;*
  - (d) management of change – adoption and implementation of procedures for planning modifications to, or the design of, new installations, processes or storage facilities;*
  - (e) planning for emergencies – adoption and implementation of procedures to identify foreseeable emergencies by systematic analysis and to prepare, test and review emergency plans to respond to such emergencies;*
  - (f) monitoring performance – adoption and implementation of procedures for the ongoing assessment of compliance with the objectives set by the duty holder major incident prevention policy and process safety management system, and the mechanisms for investigation and taking corrective action in the case of non-compliance. The procedures must cover the employer, self-employed person or user's system for reporting major incidents or near misses, particularly those involving failure of protective measures, and their investigation and follow-up on the basis of lessons learnt;*
  - (g) audit and review – adoption and implementation of procedures for periodic systematic assessment of the major incident prevention policy and the effectiveness and suitability of the process safety management system; the documented review of performance of the policy and process safety management system and its updating by senior management.*

## **ANNEXURE D**

### **SAFETY REPORTS**

**MINIMUM INFORMATION TO BE INCLUDED IN SAFETY REPORT**

*The information referred to in regulation 12(1), (5) and (7) is as follows:*

- (1) *Information on the management system and on the organisation of the establishment with a view to major incident prevention.*
- (2) A process safety management system must—
  - (a) be proportionate to the hazards, industrial activities and complexity of the organisation in the establishment;
  - (b) be based on assessment of the risks;
  - (c) include within its scope the general management system, including the organisational structure, responsibilities, practices, procedures, processes and resources for determining and implementing the major incident prevention policy.
- (3) The following matters must be addressed by the process safety management system:
  - (a) in relation to the organisation and personnel—
    - (i) the roles and responsibilities of personnel involved in the management of major hazards at all levels in the organisation, together with the measures taken to raise awareness of the need for continuous improvement;
    - (ii) the identification of the training needs of such personnel and the provision of the training;
    - (iii) the involvement of employees and of subcontracted personnel working in the establishment, who are important from the point of view of safety;
  - (b) the identification and evaluation of major hazards: the adoption and implementation of procedures for systematically identifying major hazards arising from normal and abnormal operation, including subcontracted activities where applicable, and the assessment of their likelihood and severity;
  - (c) in relation to operational control—
    - (i) the adoption and implementation of procedures and instructions for safe operation, including maintenance of plant, processes and

- equipment, and for alarm management and temporary stoppages;
- (ii) the taking into account of available information on best practices for monitoring and control, with a view to reducing the risk of system failure;
  - (iii) the management and control of the risks associated with ageing equipment installed in the establishment and its corrosion;
  - (iv) the inventory of the establishment's equipment, and the strategy and methodology for the monitoring and control of the condition of the equipment;
  - (v) appropriate follow-up actions and any necessary countermeasures;
- (d) the management of change: the adoption and implementation of procedures for planning modifications to, or the design of, new installations, processes or storage facilities;
- (e) in relation to planning for emergencies—
- (i) the adoption and implementation of procedures to identify foreseeable emergencies by systematic analysis;
  - (ii) the preparation, testing and review of emergency plans to respond to emergencies and the provision of specific training for staff, such training to be given to all personnel working in the establishment, including relevant subcontracted personnel;
- (f) in relation to monitoring performance—
- (i) the adoption and implementation of procedures for the ongoing assessment of compliance with the objectives set by the operator's major accident prevention policy and safety management system, and the mechanisms for investigation and taking corrective action in case of non-compliance;
  - (ii) the procedures must cover the operator's system for reporting major incidents or 'near misses', particularly those involving failure of protective measures, and their investigation and follow-up on the basis of lessons learned;
  - (iii) the procedures could also include performance indicators such as safety performance indicators and/or other relevant indicators;



- (g) in relation to audit and review–
  - (i) the adoption and implementation of procedures for periodic systematic assessment of the major accident prevention policy and the effectiveness and suitability of the process safety management system;
  - (ii) the documented review of performance of the policy and process safety management system and its updating by senior management, including consideration and incorporation of necessary changes indicated by the audit and review.

The information in the safety report must contain the elements set out in Annexure C.

*(4) Presentation of the site and surrounding area of the establishment:*

- (a) description of the site and its surrounding area, including the geographical location, meteorological, geographical and hydrographic conditions and, if necessary, its history;*
- (b) identification of installations and other activities of the establishment which could present a major incident hazard;*
- (c) description of areas where a major incident may occur.*

*(5) Description of the establishment:*

- (a) description of the main activities and products of the parts of the establishment which are important from the point of view of safety, sources of major incident risks and conditions under which such a major incident could happen, together with a description of proposed preventive measures;*
- (b) description of processes, in particular the operating methods;*
- (c) description of dangerous substances:*
  - (i) inventory of dangerous substances, including–*
    - (aa) the identification of dangerous substances: chemical name, the UN number;*
    - (bb) the maximum quantity of dangerous substances present;*
  - (ii) physical, chemical, toxicological characteristics and indication of the hazards, both immediate and delayed for people;*

- (iii) *physical and chemical behaviour under normal conditions of use or under potential incidental conditions.*
- (6) *Identification and incidental risks analysis and prevention methods:*
- (a) *detailed description of the possible major incident scenarios and their probability or the conditions under which they occur, including a summary of the events which may play a role in triggering each of these scenarios, the causes being internal or external to the establishment;*
  - (b) *assessment of the extent and severity of the consequences of identified major incidents;*
  - (c) *description of technical consideration, methods and tools used for the safety evaluation of the establishment.*
- (7) *Measures of protection and intervention to limit the consequences of an incident:*
- (a) *description of the equipment installed in the plant to limit the consequences of major incidents;*
  - (b) *organisational alert and intervention;*
  - (c) *description of internal or external resources that can be mobilised;*
  - (d) *summary of elements described in subparagraphs (a), (b) and (c);*
  - (e) *necessity for drawing up the on-site emergency plan.*

**ANNEXURE E**

AIA REPORTS: \_\_\_\_\_

: \_\_\_\_\_ **AIA number:** \_\_\_\_\_

<i>Physical address</i>	<i>Type</i>	<i>Responsible person</i>	<i>Assessor</i>	<i>Type of assessment</i>	<i>Date of previous assessment</i>	<i>Date of assessment</i>

**FORM A**  
**NOTIFICATION OF AN ESTABLISHMENT**

**(Regulation 4)**

*Detailed guidance can be obtained from the Major Hazard Installation Regulations, 2022, which is available on the Department of Employment and Labour's website, [www.labour.gov.za](http://www.labour.gov.za).*

*The completed form must be hand-delivered to the Department of Employment and Labour's offices.*

**Physical address:**

*215 Francis Baard Street  
Laboria House Building  
Pretoria  
0001*

*Or, alternatively, you may make enquiries by email to [webmail@labour.gov.za](mailto:webmail@labour.gov.za). As electronic communication cannot be guaranteed to be secure, you may decide not to use this means if you regard any of the information as confidential.*

*A determination must be made by the applicant who the correct recipient at the local government is. This recipient must be an appropriate member from the relevant section or senior management at the local government.*

## 2. BASIC PARTICULARS OF THE ESTABLISHMENT

Name of the establishment:	
Registered name of the business:	
Company Registration No.:	
Chief Executive Officer:	
CEO's physical address:	
CEO's telephone number:	
Name of the responsible person and contact:	
Physical address of the establishment:	
Telephone number of the establishment:	
Email:	
Industry sector:	
Brief description of activity or proposed activity concerned:	
Health and safety representative(s). (At least two, where applicable)	
Trade Union	

## 2. CLASSIFICATION

2.1 Type of hazard of the establishment (mark with an X)

<b>Low</b>		<b>Medium</b>		<b>High</b>	
------------	--	---------------	--	-------------	--

2.2 Type of notification

<b>Proposed</b>		<b>Renewal</b>		<b>Review due to changes</b>	
-----------------	--	----------------	--	------------------------------	--

Comment on the lifetime of the establishment:

---



---



---



---

2.3 When did the assessment expire? \_\_\_\_\_

2.4 Age of the establishment \_\_\_\_\_

2.5 Subsequent risk assessments

<b>DATE OF MHI RISK ASSESSMENT</b>	<b>TYPE OF MHI RISK ASSESSMENT</b>	<b>AIA</b>

2.6 Date of evaluation of current risk assessment: \_\_\_\_\_

2.7 Were the employees consulted and informed of the status of the establishment?

<b>Yes</b>	<input type="checkbox"/>	<b>No</b>	<input type="checkbox"/>
------------	--------------------------	-----------	--------------------------

*Attach proof*

*If not, provide a reason:*

---



---



---



---

**3. PUBLIC AWARENESS**

3.1 Were the neighbours and public notified?

<b>Yes</b>	<input type="checkbox"/>	<b>No</b>	<input type="checkbox"/>
------------	--------------------------	-----------	--------------------------

*Attach proof*

*If not, provide a reason:*

---



---



---



---

3.2 *Were there any objections?*

<b>Yes</b>		<b>No</b>	
------------	--	-----------	--

*Attach proof*

*If yes, provide a reason:*

---



---



---

3.3 *Were the objections regarding health and safety of the public?*

<b>Yes</b>		<b>No</b>	
------------	--	-----------	--

*Attach proof*

*If yes, provide a reason and resolutions:*

---



---



---

**4. INVENTORY OF SUBSTANCES**

*Provide an inventory list of all substances that will be present, their physical form and quantity.*

*Physical form includes gas, liquid, powder and solids. Quantity is the maximum which is anticipated will be present. The information as in Annexure A must be used.*

<b>Name of substance</b>	<b>Physical form</b>	<b>Maximum quantity</b>

	<i>Details of the elements of the immediate environment liable to cause a major incident or aggravate the consequences thereof:</i>
<i>Describe other establishments or features of environment which could lead to a major incident on your site. Describe elements of surrounding environment which could make the consequences of a major incident worse (e.g. nearby housing, other occupied buildings, farming and sewage works)</i>	<b>Neighbouring establishments</b>
	<b>Surrounding vulnerabilities</b>
	<b>Other</b>

## **5. DETAILS OF APPROVED INSPECTION AUTHORITY (AIA)**

5.1 Name of the AIA (as relevant): \_\_\_\_\_

5.2 AIA number: \_\_\_\_\_

(Attach certificate)

5.3 SANAS certificate number: \_\_\_\_\_

(Attach certificate and schedule)

5.4 Name of assessor: \_\_\_\_\_

(Attach competency records)

5.5 Telephone number: \_\_\_\_\_



**6. SITE MAPS**

*Attach proof*

**7. LOCAL GOVERNMENT**

7.1 Name of local government: \_\_\_\_\_

7.2 Contact person: \_\_\_\_\_

7.3 Contact details: \_\_\_\_\_

7.4 Province: \_\_\_\_\_

*Attach proof of advertisement of the status*

7.5 Land use approval status

<b>Yes</b>		<b>No</b>	
------------	--	-----------	--

*Attach proof*

*If not, state the reasons and attach proof of when the permit will be submitted:*

---



---



---



---

7.6 Acknowledgement by local government

*Official Stamp*

Received by: \_\_\_\_\_

DESIGNATION: \_\_\_\_\_

Contact: \_\_\_\_\_

Signature: \_\_\_\_\_

**8. EMERGENCY PREPAREDNESS**

8.1 Emergency preparedness plans

(a) On-site plan

<b>Yes</b>		<b>No</b>	
------------	--	-----------	--

*Attach proof*

*If not yet concluded, attach action plan with clear target dates of not more than six months and comment below:*

---



---



---



---

(b) *Off-site plan*

<b>Yes</b>		<b>No</b>	
------------	--	-----------	--

*Attach proof*

*If not yet concluded, attach action plan with clear target dates of not more than six months and comment below:*

---



---



---



---

**8.2** *Relevant local government responsible for activating emergency plans*

*Name:* \_\_\_\_\_

*Contact Person:* \_\_\_\_\_

*Designation:* \_\_\_\_\_

*Was there an agreement between the establishment and the local government?*

<b>Yes</b>		<b>No</b>	
------------	--	-----------	--

*Attach proof*

*If no, comment and attach certificate of designation:*

---



---



---



---

**8.3** *What is the upcoming revision period (maximum of three years)?*

---

8.4 *Were employees consulted?*

<b>Yes</b>		<b>No</b>	
------------	--	-----------	--

*Attach proof*

*Attach consent statement from relevant health and safety representative(s) or health and safety committee.*

8.5 *Were employees trained on emergency preparedness and procedures to follow during all types of emergencies?*

<b>Yes</b>		<b>No</b>	
------------	--	-----------	--

*Attach proof*

## **9. SIGNATURES**

9.1 *Establishment Representative*

*Name and Surname:* \_\_\_\_\_ *Position:* \_\_\_\_\_

*Date:* \_\_\_\_\_

*Attach letterhead of the establishment*

9.2 *Responsible Person*

*Name and Surname:* \_\_\_\_\_ *Position:* \_\_\_\_\_

*Date:* \_\_\_\_\_

*Attach appointment letter*

**FORM B****APPLICATION FOR REGISTRATION AS APPROVED INSTALLATION  
INSPECTION AUTHORITY****DEPARTMENT OF EMPLOYMENT AND LABOUR  
OCCUPATIONAL HEALTH AND SAFETY ACT, 1993 (ACT NO. 85 OF 1993)**

<i>The Chief Inspector Department of Employment and Labour Private Bag X117 PRETORIA, 0001</i>	
------------------------------------------------------------------------------------------------------------	--

*The Chief Inspector*

*I hereby apply to be registered as an approved inspection authority for major hazard establishments in terms of regulation 19 of the Major Hazard Installation Regulations, 2022. I declare that the particulars given below are, to the best of my knowledge and belief, correct.*

**1. PARTICULARS OF INSPECTION BODY**

*Registered name of Inspection Body:* \_\_\_\_\_

*Trading name:* \_\_\_\_\_

*State whether you are a sole proprietor/partnership/company/close corporation (delete which is not applicable)*

*Business registration number:* \_\_\_\_\_

*Chief Executive Officer:* \_\_\_\_\_

*Partners:* \_\_\_\_\_

*Province:* \_\_\_\_\_

*Physical Address:* \_\_\_\_\_

## 2. SCOPE OF APPLICATION (Tick appropriate block(s))

TYPE A	3 <sup>d</sup> party	
TYPE B	In-house	
TYPE C	Manufacturer	

## 3. SIGNATORIES:

3.1 \_\_\_\_\_

3.2 \_\_\_\_\_

## 4. SPECIMEN SIGNATURE OF THE SIGNATORIES:

1	2	3	4
3.1			
3.2			

*Attach more if there are many***SUPPORTING DOCUMENTS**

- (a) Certified copy of IDs
- (b) Certified copy of business registration
- (c) Organogram of the inspection body
- (d) Certified copy of accreditation certificate and schedule from the accreditation body

Signature of the applicant \_\_\_\_\_

Date of application: \_\_\_\_\_

FOR OFFICE USE

Application : APPROVED/NOT APPROVED

REASON FOR REFUSAL: \_\_\_\_\_

\_\_\_\_\_

COMMENTS: \_\_\_\_\_

\_\_\_\_\_

\_\_\_\_\_

\_\_\_\_\_

\_\_\_\_\_

Allocated Registration Number: \_\_\_\_\_

Approving Official: \_\_\_\_\_

Signature: \_\_\_\_\_

Date: \_\_\_\_\_

Printed by and obtainable from the Government Printer, Bosman Street, Private Bag X85, Pretoria, 0001  
Contact Centre Tel: 012-748 6200. eMail: [info.egazette@gpw.gov.za](mailto:info.egazette@gpw.gov.za)  
Publications: Tel: (012) 748 6053, 748 6061, 748 6065

**13 APPENDIX B: PADHI LAND-PLANNING TABLES**

**13.1 Development Type Table 1: People at Work, Parking**

<b>Development Type</b>	<b>Examples</b>	<b>Development Detail and Size</b>	<b>Justification</b>
<b>DT1.1 Workplaces</b>	Offices, factories, warehouses, haulage depots, farm buildings, nonretail markets, builder's yards	Workplaces (predominantly nonretail), providing for less than 100 occupants in each building and less than 3 occupied storeys (Level 1)	Places where the occupants will be fit and healthy and could be organised easily for emergency action Members of the public will not be present or will be present in very small numbers and for a short time
	<b>Exclusions</b>		
		DT1.1 x1 Workplaces (predominantly nonretail) providing for 100 or more occupants in any building or 3 or more occupied storeys in height (Level 2 except where the development is at the major hazard site itself, where it remains Level 1)	Substantial increase in numbers at risk with no direct benefit from exposure to the risk
	Sheltered workshops, Remploy	DT1.1 x2 Workplaces (predominantly nonretail) specifically for people with disabilities (Level 3)	Those at risk may be especially vulnerable to injury from hazardous events or they may not be able to be organised easily for emergency action
<b>DT1.2 Parking Areas</b>	Car parks, truck parks, lockup garages	Parking areas with no other associated facilities (other than toilets; Level 1)	
	<b>Exclusions</b>		
	Car parks with picnic areas or at a retail or leisure development or serving a park and ride interchange	DT1.2 x1 Where parking areas are associated with other facilities and developments the sensitivity level and the decision will be based on the facility or development	



**13.2 Development Type Table 2: Developments for Use by the General Public**

<b>Development Type</b>	<b>Examples</b>	<b>Development Detail and Size</b>	<b>Justification</b>
<b>DT2.1 Housing</b>	Houses, flats, retirement flats or bungalows, residential caravans, mobile homes	Developments up to and including 30 dwelling units and at a density of no more than 40 per hectare (Level 2)	Development where people live or are temporarily resident It may be difficult to organise people in the event of an emergency
	<b>Exclusions</b>		
	Infill, back-land development	DT2.1 x1 Developments of 1 or 2 dwelling units (Level 1)	Minimal increase in numbers at risk
	Larger housing developments	DT2.1 x2 Larger developments for more than 30 dwelling units (Level 3)	Substantial increase in numbers at risk
		DT2.1 x3 Any developments (for more than 2 dwelling units) at a density of more than 40 dwelling units per hectare (Level 3)	High-density developments
<b>DT2.2 Hotel or Hostel or Holiday Accommodation</b>	Hotels, motels, guest houses, hostels, youth hostels, holiday camps, holiday homes, halls of residence, dormitories, accommodation centres, holiday caravan sites, camping sites	Accommodation up to 100 beds or 33 caravan or tent pitches (Level 2)	Development where people are temporarily resident It may be difficult to organise people in the event of an emergency
	<b>Exclusions</b>		
	Smaller: guest houses, hostels, youth hostels, holiday homes, halls of residence, dormitories, holiday caravan sites, camping sites	DT2.2 x1 Accommodation of less than 10 beds or 3 caravan or tent pitches (Level 1)	Minimal increase in numbers at risk
	Larger: hotels, motels, hostels, youth hostels, holiday camps, holiday homes, halls of residence, dormitories, holiday caravan sites, camping sites	DT2.2 x2 Accommodation of more than 100 beds or 33 caravan or tent pitches (Level 3)	Substantial increase in numbers at risk

Development Type	Examples	Development Detail and Size	Justification
<b>DT2.3 Transport Links</b>	Motorway, dual carriageway	Major transport links in their own right i.e., not as an integral part of other developments (Level 2)	Prime purpose is as a transport link Potentially large numbers exposed to risk but exposure of an individual is only for a short period
	<b>Exclusions</b>		
	Estate roads, access roads	DT2.3 x1 Single carriageway roads (Level 1)	Minimal numbers present and mostly a small period of time exposed to risk Associated with other development
Any railway or tram track	DT2.3 x2 Railways (Level 1)	Transient population, small period of time exposed to risk Periods of time with no population present	

Development Type	Examples	Development Detail and Size	Justification
<p><b>DT2.4 Indoor Use by Public</b></p>	<p>Food and drink: restaurants, cafes, drive-through fast food, pubs Retail: shops, petrol filling station (total floor space based on shop area not forecourt), vehicle dealers (total floor space based on showroom or sales building not outside display areas), retail warehouses, super-stores, small shopping centres, markets, financial and professional services to the public Community and adult education: libraries, art galleries, museums, exhibition halls, day surgeries, health centres, religious buildings, community centres. adult education, 6th form college, college of FE Assembly and leisure: Coach or bus or railway stations, ferry terminals, airports, cinemas, concert or bingo or dance halls, conference centres, sports or leisure centres, sports halls, facilities associated with golf courses, flying clubs (e.g., changing rooms, club house), indoor go kart tracks</p>	<p>Developments for use by the general public where total floor space is from 250 m<sup>2</sup> up to 5000 m<sup>2</sup> (Level 2)</p>	<p>Developments where members of the public will be present (but not resident) Emergency action may be difficult to coordinate</p>
	<b>Exclusions</b>		
		<p>DT2.4 x1 Development with less than 250 m<sup>2</sup> total floor space (Level 1)</p>	<p>Minimal increase in numbers at risk</p>
	<p>DT2.4 x2 Development with more than 5000 m<sup>2</sup> total floor space (Level 3)</p>	<p>Substantial increase in numbers at risk</p>	
<p><b>DT2.5 Outdoor Use by Public</b></p>	<p>Food and drink: food festivals, picnic areas Retail: outdoor markets, car boot sales, funfairs Community and adult</p>	<p>Principally an outdoor development for use by the general public i.e., developments where people will</p>	<p>Developments where members of the public will be present (but not resident)</p>

Development Type	Examples	Development Detail and Size	Justification
	education: open-air theatres and exhibitions Assembly and leisure: coach or bus or railway stations, park and ride interchange, ferry terminals, sports stadia, sports fields or pitches, funfairs, theme parks, viewing stands, marinas, playing fields, children's play areas, BMX or go kart tracks, country parks, nature reserves, picnic sites, marquees	predominantly be outdoors and not more than 100 people will gather at the facility at any one time (Level 2)	either indoors or outdoors Emergency action may be difficult to coordinate
<b>Exclusions</b>			
	Outdoor markets, car boot sales, funfairs picnic area, park and ride interchange, viewing stands, marquees	DT2.5 x1 Predominantly open-air developments likely to attract the general public in numbers greater than 100 people but up to 1000 at any one time (Level 3)	Substantial increase in numbers at risk and more vulnerable due to being outside
	Theme parks, funfairs, large sports stadia and events, open air markets, outdoor concerts, pop festivals	DT2.5 x2 Predominantly open-air developments likely to attract the general public in numbers greater than 1000 people at any one time (Level 4)	Very substantial increase in numbers at risk, more vulnerable due to being outside Emergency action may be difficult to coordinate

**13.3 Development Type Table 3: Developments for Use by Vulnerable People**

<b>Development Type</b>	<b>Examples</b>	<b>Development Detail and Size</b>	<b>Justification</b>
<b>DT3.1 Institutional Accommodation and Education</b>	Hospitals, convalescent homes, nursing homes, old people's homes with warden on site or 'on call', sheltered housing, nurseries, crèches, schools and academies for children up to school leaving age	Institutional, educational and special accommodation for vulnerable people or that provides a protective environment (Level 3)	Places providing an element of care or protection Because of age, infirmity or state of health the occupants may be especially vulnerable to injury from hazardous events Emergency action and evacuation may be very difficult
	<b>Exclusions</b>		
	Hospitals, convalescent homes, nursing homes, old people's homes, sheltered housing	DT3.1 x1 24-hour care where the site on the planning application being developed is larger than 0.25 hectare (Level 4)	Substantial increase in numbers of vulnerable people at risk
	Schools, nurseries, crèches	DT3.1 x2 Day care where the site on the planning application being developed is larger than 1.4 hectare (Level 4)	Substantial increase in numbers of vulnerable people at risk
<b>DT3.2 Prisons</b>	Prisons, remand centres	Secure accommodation for those sentenced by court, or awaiting trial, etc. (Level 3)	Places providing detention Emergency action and evacuation may be very difficult

**13.4 Development Type Table 4: Very Large and Sensitive Developments**

<b>Development Type</b>	<b>Examples</b>	<b>Development Detail and Size</b>	<b>Justification</b>
Note: all Level 4 developments are by exception from Level 2 or 3 and are reproduced in this table for convenient reference			
<b>DT4.1 Institutional Accommodation</b>	Hospitals, convalescent homes, nursing homes, old people's homes, sheltered housing	Large developments of institutional and special accommodation for vulnerable people (or that provide a protective environment) where 24-hour care is provided and where the site on the planning application being developed is larger than 0.25 hectare (Level 4)	Places providing an element of care or protection Because of age or state of health the occupants may be especially vulnerable to injury from hazardous events Emergency action and evacuation may be very difficult The risk to an individual may be small but there is a larger societal concern
	Nurseries, crèches, schools for children up to school leaving age	Large developments of institutional and special accommodation for vulnerable people (or that provide a protective environment) where day care (not 24-hour care) is provided and where the site on the planning application being developed is larger than 1.4 hectare (Level 4)	Places providing an element of care or protection Because of the occupants may be especially vulnerable to injury from hazardous events Emergency action and evacuation may be very difficult The risk to an individual may be small but there is a larger societal concern
<b>DT4.2 Very Large Outdoor Use by Public</b>	Theme parks, large sports stadia and events, open air markets, outdoor concerts, pop festivals	Predominantly open-air developments where there could be more than 1000 people present (Level 4)	People in the open air may be more exposed to toxic fumes and thermal radiation than if they were in buildings Large numbers make emergency action and evacuation difficult The risk to an individual may be small but there is a larger societal concern

**14 APPENDIX C: INCIDENT SCENARIOS**

**14.1 Pool Fires**

**14.1.1 Tank – Catastrophic failure**

Scenario [No]	Equipment	Medium	Area of Release (m <sup>2</sup> )	Event Frequency / Annum	System Reaction 1	System Reaction 1 Probability	System Reaction 2	System Reaction 2 Probability	Probability of Ignition	Total System Event Frequency / Annum
FL-01	T-01	Jet A-1	1020	5.00E-06	None	1.00E+00	None	1.00E+00	4.30E-03	2.15E-08
FL-02	T-02	Jet A-1	1020	5.00E-06	None	1.00E+00	None	1.00E+00	4.30E-03	2.15E-08
FL-03	T-03	Jet A-1	1020	5.00E-06	None	1.00E+00	None	1.00E+00	4.30E-03	2.15E-08
FL-04	T-04	Jet A-1	1020	5.00E-06	None	1.00E+00	None	1.00E+00	4.30E-03	2.15E-08
FL-05	T-05	Jet A-1	1020	5.00E-06	None	1.00E+00	None	1.00E+00	4.30E-03	2.15E-08
FL-06	T-06	Jet A-1	1020	5.00E-06	None	1.00E+00	None	1.00E+00	4.30E-03	2.15E-08
FL-07	T-07	Jet A-1	1020	5.00E-06	None	1.00E+00	None	1.00E+00	4.30E-03	2.15E-08
FL-08	T-08	Jet A-1	1020	5.00E-06	None	1.00E+00	None	1.00E+00	4.30E-03	2.15E-08
FL-09	T-09	Jet A-1	1020	5.00E-06	None	1.00E+00	None	1.00E+00	4.30E-03	2.15E-08
FL-10	T-10	Jet A-1	1020	5.00E-06	None	1.00E+00	None	1.00E+00	4.30E-03	2.15E-08
FL-11	T-11	Avgas	157.5	1.25E-08	None	1.00E+00	None	1.00E+00	6.50E-02	8.13E-10
FL-12	T-12	Avgas	157.5	1.25E-08	None	1.00E+00	None	1.00E+00	6.50E-02	8.13E-10
FL-13	T-13	Avgas	157.5	1.25E-08	None	1.00E+00	None	1.00E+00	6.50E-02	8.13E-10
FL-14	T-14	Jet A-1	367.5	5.00E-06	None	1.00E+00	None	1.00E+00	4.30E-03	2.15E-08
FL-14	T-15	Jet A-1	367.5	5.00E-06	None	1.00E+00	None	1.00E+00	4.30E-03	2.15E-08
FL-14	T-16	Jet A-1	367.5	5.00E-06	None	1.00E+00	None	1.00E+00	4.30E-03	2.15E-08

14.1.2 Tank – Severe Leak Failure

Scenario [No]	Equipment	Medium	Area of Release (m <sup>2</sup> )	Event Frequency / Annum	System Reaction 1	System Reaction 1 Probability	System Reaction 2	System Reaction 2 Probability	Probability of Ignition	Total System Event Frequency / Annum
FL-101	T-01	Jet A-1	680	3.00E-05	None	1.00E+00	None	1.00E+00	4.30E-03	1.29E-07
FL-102	T-02	Jet A-1	680	3.00E-05	None	1.00E+00	None	1.00E+00	4.30E-03	1.29E-07
FL-103	T-03	Jet A-1	680	3.00E-05	None	1.00E+00	None	1.00E+00	4.30E-03	1.29E-07
FL-104	T-04	Jet A-1	680	3.00E-05	None	1.00E+00	None	1.00E+00	4.30E-03	1.29E-07
FL-105	T-05	Jet A-1	680	3.00E-05	None	1.00E+00	None	1.00E+00	4.30E-03	1.29E-07
FL-106	T-06	Jet A-1	680	3.00E-05	None	1.00E+00	None	1.00E+00	4.30E-03	1.29E-07
FL-107	T-07	Jet A-1	680	3.00E-05	None	1.00E+00	None	1.00E+00	4.30E-03	1.29E-07
FL-108	T-08	Jet A-1	680	3.00E-05	None	1.00E+00	None	1.00E+00	4.30E-03	1.29E-07
FL-109	T-09	Jet A-1	680	3.00E-05	None	1.00E+00	None	1.00E+00	4.30E-03	1.29E-07
FL-110	T-10	Jet A-1	680	3.00E-05	None	1.00E+00	None	1.00E+00	4.30E-03	1.29E-07
FL-111	T-11	Avgas	105	1.25E-08	None	1.00E+00	None	1.00E+00	6.50E-02	8.13E-10
FL-112	T-12	Avgas	105	1.25E-08	None	1.00E+00	None	1.00E+00	6.50E-02	8.13E-10
FL-113	T-13	Avgas	105	1.25E-08	None	1.00E+00	None	1.00E+00	6.50E-02	8.13E-10
FL-114	T-14	Jet A-1	245	3.00E-05	None	1.00E+00	None	1.00E+00	4.30E-03	1.29E-07
FL-115	T-15	Jet A-1	245	3.00E-05	None	1.00E+00	None	1.00E+00	4.30E-03	1.29E-07
FL-116	T-16	Jet A-1	245	3.00E-05	None	1.00E+00	None	1.00E+00	4.30E-03	1.29E-07



**14.1.3 Tank Overfilling**

Scenario [No]	Equipment	Medium	Area of Release (m <sup>2</sup> )	Event Frequency / Annum	System Reaction 1	System Reaction 1 Probability	System Reaction 2	System Reaction 2 Probability	Probability of Ignition	Total System Event Frequency / Annum
FL-101	T-01	Jet A-1	680	1.00E-02	None	1.00E+00	None	1.00E+00	4.30E-03	4.30E-05
FL-102	T-02	Jet A-1	680	1.00E-02	None	1.00E+00	None	1.00E+00	4.30E-03	4.30E-05
FL-103	T-03	Jet A-1	680	1.00E-02	None	1.00E+00	None	1.00E+00	4.30E-03	4.30E-05
FL-104	T-04	Jet A-1	680	1.00E-02	None	1.00E+00	None	1.00E+00	4.30E-03	4.30E-05
FL-105	T-05	Jet A-1	680	1.00E-02	None	1.00E+00	None	1.00E+00	4.30E-03	4.30E-05
FL-106	T-06	Jet A-1	680	1.00E-02	None	1.00E+00	None	1.00E+00	4.30E-03	4.30E-05
FL-107	T-07	Jet A-1	680	1.00E-02	None	1.00E+00	None	1.00E+00	4.30E-03	4.30E-05
FL-108	T-08	Jet A-1	680	1.00E-02	None	1.00E+00	None	1.00E+00	4.30E-03	4.30E-05
FL-109	T-09	Jet A-1	680	1.00E-02	None	1.00E+00	None	1.00E+00	4.30E-03	4.30E-05
FL-110	T-10	Jet A-1	680	1.00E-02	None	1.00E+00	None	1.00E+00	4.30E-03	4.30E-05
FL-111	T-11	Avgas	105	1.00E-02	None	1.00E+00	None	1.00E+00	6.50E-02	6.50E-04
FL-112	T-12	Avgas	105	1.00E-02	None	1.00E+00	None	1.00E+00	6.50E-02	6.50E-04
FL-113	T-13	Avgas	105	1.00E-02	None	1.00E+00	None	1.00E+00	6.50E-02	6.50E-04
FL-114	T-14	Jet A-1	245	1.00E-02	None	1.00E+00	None	1.00E+00	4.30E-03	4.30E-05
FL-115	T-15	Jet A-1	245	1.00E-02	None	1.00E+00	None	1.00E+00	4.30E-03	4.30E-05
FL-116	T-16	Jet A-1	245	1.00E-02	None	1.00E+00	None	1.00E+00	4.30E-03	4.30E-05

14.1.4 Tank Top Fires

Scenario [No]	Equipment	Medium	Area of Release (m <sup>2</sup> )	Event Frequency / Annum	System Reaction 1	System Reaction 1 Probability	System Reaction 2	System Reaction 2 Probability	Probability of Ignition	Total System Event Frequency / Annum
FL-301	T-01	Jet A-1	0	0.00E+00	None	1	None	1	4.30E-03	0.00E+00
FL-302	T-02	Jet A-1	0	0.00E+00	None	1	None	1	4.30E-03	0.00E+00
FL-303	T-03	Jet A-1	0	0.00E+00	None	1	None	1	6.50E-02	0.00E+00
FL-304	T-04	Jet A-1	0	0.00E+00	None	1	None	1	4.30E-03	0.00E+00
FL-305	T-05	Jet A-1	0	0.00E+00	None	1	None	1	4.30E-03	0.00E+00
FL-306	T-06	Jet A-1	0	0.00E+00	None	1	None	1	4.30E-03	0.00E+00
FL-307	T-07	Jet A-1	0	0.00E+00	None	1	None	1	6.50E-02	0.00E+00
FL-306	T-08	Jet A-1	0	0.00E+00	None	1	None	1	6.50E-02	0.00E+00
FL-306	T-09	Jet A-1	0	0.00E+00	None	1	None	1	6.50E-02	0.00E+00
FL-306	T-10	Jet A-1	0	0.00E+00	None	1	None	1	6.50E-02	0.00E+00
FL-306	T-11	Avgas	0	0.00E+00	None	1	None	1	6.50E-02	0.00E+00
FL-306	T-12	Avgas	0	0.00E+00	None	1	None	1	6.50E-02	0.00E+00
FL-306	T-13	Avgas	0	0.00E+00	None	1	None	1	6.50E-02	0.00E+00
FL-306	T-14	Jet A-1	25	1.00E-05	None	1	None	1	6.50E-02	6.50E-07
FL-306	T-15	Jet A-1	25	1.00E-05	None	1	None	1	6.50E-02	6.50E-07
FL-306	T-16	Jet A-1	25	1.00E-05	None	1	None	1	6.50E-02	6.50E-07

14.1.5 Tank Explosions

Scenario [No]	Equipment	Medium	Explosive Mass (kg)	Event Frequency / Annum	System Reaction 1	System Reaction 1 Probability	System Reaction 2	System Reaction 2 Probability	Probability of Ignition	Total System Event Frequency / Annum
FL-301	T-01	Jet A-1		0.00E+00	Frac of explosion	4.00E-01	None	1	0.00E+00	0.00E+00
FL-302	T-02	Jet A-1		0.00E+00	Frac of explosion	4.00E-01	None	1	0.00E+00	0.00E+00
FL-303	T-03	Jet A-1	0	1.00E+00	Frac of explosion	4.00E-01	None	1	0.00E+00	0.00E+00
FL-304	T-04	Jet A-1	0	0.00E+00	Frac of explosion	4.00E-01	None	1	0.00E+00	0.00E+00
FL-305	T-05	Jet A-1	0	0.00E+00	Frac of explosion	4.00E-01	None	1	0.00E+00	0.00E+00
FL-306	T-06	Jet A-1		0.00E+00	Frac of explosion	4.00E-01	None	1	0.00E+00	0.00E+00
FL-307	T-07	Jet A-1		1.00E+00	Frac of explosion	4.00E-01	None	1	0.00E+00	0.00E+00
FL-308	T-08	Jet A-1		1.00E+00	Frac of explosion	4.00E-01	None	1	0.00E+00	0.00E+00
FL-309	T-09	Jet A-1		1.00E+00	Frac of explosion	4.00E-01	None	1	0.00E+00	0.00E+00
FL-310	T-10	Jet A-1		1.00E+00	Frac of explosion	4.00E-01	None	1	6.50E-02	2.60E-02
FL-311	T-11	Avgas	1.08	3.00E-05	Frac of explosion	4.00E-01	None	1	6.50E-02	7.80E-07
FL-312	T-12	Avgas	1.08	3.00E-05	Frac of explosion	4.00E-01	None	1	6.50E-02	7.80E-07
FL-313	T-13	Avgas	0.32	3.00E-05	Frac of explosion	4.00E-01	None	1	6.50E-02	7.80E-07
FL-314	T-14	Jet A-1		0.00E+00	Frac of explosion	4.00E-01	None	1	0.00E+00	0.00E+00
FL-315	T-15	Jet A-1		0.00E+00	Frac of explosion	4.00E-01	None	1	0.00E+00	0.00E+00
FL-316	T-16	Jet A-1		0.00E+00	Frac of explosion	4.00E-01	None	1	0.00E+00	0.00E+00

**14.1.6 Road Tanker Loading / Offloading**

Scenario [No]	Equipment	Scenario	Area of Release	Event Frequency / Annum	System Reaction 1	System Reaction 1 Probability	System Reaction 2	System Reaction 2 Probability	Probability of Ignition	Total System Event Frequency / Annum
D-01	Road tanker (Jet A-1)	Failure	71	1.00E-05	Frac time on site	0.300	None	1	0.0043	1.29E-08
D-02	Road tanker (Jet A-1)	Release from nozzle	71	1.00E-07	Frac time on site	0.300	None	1	0.0043	1.29E-10
D-03	Tanker Hose (Jet A-1)	Rupture of offloading hose	71	3.50E-02	Frac time on site	0.300	Intervention by operator	0.1	0.0043	4.52E-06
D-04	Tanker Hose (Jet A-1)	Leak of offloading hose	71	3.50E-01	Frac time on site	0.300	Intervention by operator	0.1	0.0043	4.52E-05
D-05	Road tanker (Avgas)	Failure	71	1.00E-05	Frac time on site	0.300	None	1	0.065	1.95E-07
D-06	Road tanker (Avgas)	Release from nozzle	71	1.00E-07	Frac time on site	0.300	None	1	0.065	1.95E-09
D-07	Tanker Hose (Avgas)	Rupture of offloading hose	91	3.50E-02	Frac time on site	0.300	Intervention by operator	0.1	0.065	6.83E-05
D-08	Tanker Hose (Avgas)	Leak of offloading hose	91	3.50E-01	Frac time on site	0.300	Intervention by operator	0.1	0.065	6.83E-04

15 APPENDIX D: PROOF OF COMPETANCY

15.1 Department of Employment and Labour Certificate

  
**employment & labour**  
Department:  
Employment and Labour  
REPUBLIC OF SOUTH AFRICA

National Department of Employment and Labour  
Republic of South Africa

**APPROVED INSPECTION AUTHORITY**  
*Registered in accordance with the provisions of the Occupational Health and Safety Act, Act 85 of 1993, as amended and the Major Hazard Installation Regulations.*

THIS IS TO CERTIFY THAT:

**RISCOM (PTY) LTD**

*has been registered by the Department of Employment and Labour as an Approved Inspection Authority: Type A, to conduct Major Hazard Installation Risk Assessment, in terms of Regulation 5(5)(a), of the Major Hazard Installation Regulations.*

**CONDITIONS OF REGISTRATION:**

- *The AIA must at all time comply with the requirements of the Occupational Health and Safety Act, Act 85 of 1993, as amended.*
- *This registration certificate is not transferable.*
- *This registration will lapse if there is a name change of the AIA or change in ownership.*

  
**CHIEF INSPECTOR**



*Valid from: 27 May 2021  
Expires: 26 May 2025  
Certificate Number: CI MHI 0005*

## 15.2 SANAS Certificate



### CERTIFICATE OF ACCREDITATION

*In terms of section 22(2)(b) of the Accreditation for Conformity Assessment, Calibration and Good Laboratory Practice Act, 2006 (Act 19 of 2006), read with sections 23(1), (2) and (3) of the said Act, I hereby certify that:-*

**RISCOM (PTY) LTD**  
Co. Reg. No.: 2002/019697/07  
JOHANNESBURG

Accreditation Number: **MHI0013**

is a South African National Accreditation System Accredited Inspection Body to undertake **TYPE A** inspection provided that all SANAS conditions and requirements are complied with

This certificate is valid as per the scope as stated in the accompanying scope of accreditation, Annexure "A", bearing the above accreditation number for

#### **THE ASSESSMENT OF RISK ON MAJOR HAZARD INSTALLATIONS**

The facility is accredited in accordance with the recognised International Standard

**ISO/IEC 17020:2012 AND SANS 1461:2018**

The accreditation demonstrates technical competency for a defined scope and the operation of a management system

While this certificate remains valid, the Accredited Facility named above is authorised to use the relevant SANAS accreditation symbol to issue facility reports and/or certificates

A handwritten signature in black ink, appearing to read 'M Phaloane', is written over a horizontal line.

Mr M Phaloane  
Acting Chief Executive Officer

Effective Date: 27 May 2021  
Certificate Expires: 26 May 2025

This certificate does not on its own confer authority to act as an Approved Inspection Authority as contemplated in the Major Hazard Installation Regulations. Approval to inspect within the regulatory domain is granted by the Department of Employment and Labour.



**15.3 Scope of Accreditation**

ANNEXURE A  
**SCOPE OF ACCREDITATION**

Accreditation Number: MHI0013

TYPE A

<p><b>Permanent Address:</b> Riscom (Pty) Ltd 541 Heron Place Maroeladal Randburg 2191</p> <p>Tel: (011) 431-2198 Fax: 086 624-9423 Mobile: 082 457-3258 E-mail: <a href="mailto:mike@riscom.co.za">mike@riscom.co.za</a></p>	<p><b>Postal Address:</b> Postal Address Postnet Suite 010 Private Bag X153 Bryanston 2021</p> <p>Issue No.: 18 Date of issue: 19 February 2024 Expiry date: 26 May 2025</p>	
<p><b>Nominated Representative:</b> Mr MP Oberholzer</p>	<p><b>Quality Manager:</b> Mr MP Oberholzer</p> <p><b>Technical Manager:</b> Mr MP Oberholzer</p>	<p><b>Technical Signatory:</b> Mr MP Oberholzer</p>
<p><b>Field of Inspection</b></p>	<p><b>Service Rendered</b></p>	<p><b>Codes and Regulations</b></p>
<p><b>Regulatory:</b> The supply of services as an Inspection Authority for Major Hazard Risk Installation as defined in the Major Hazard Risk Installation Regulations, Government Notice No. R692 of 30 July 2001</p> <p><b>Voluntary</b> Supply of service as an inspection body for Hazard identification and analysis</p>	<p>Major Hazard Installation Risk Assessments for the following material categories:</p> <ol style="list-style-type: none"> <li>1) Explosive chemicals</li> <li>2) Gases:             <ol style="list-style-type: none"> <li>i) Flammable Gases</li> <li>ii) Non-flammable, non-toxic gases (asphyxiants)</li> <li>iii) Toxic gases</li> </ol> </li> <li>3) Flammable liquids</li> <li>4) Flammable solids, substances liable to spontaneous combustion, substances that on contact with water release flammable gases</li> <li>5) Oxidizing substances and organic peroxides</li> <li>6) Toxic liquids and solids</li> </ol> <p>Hazard identification and analysis including HAZARD of and operability studies (HAZOP)</p>	<p>MHI regulation par. 5 (5) (b)</p> <ol style="list-style-type: none"> <li>i) Frequency/Probability Analysis</li> <li>ii) Consequence Modelling</li> <li>iii) Hazard Identification and Analysis</li> <li>iv) Emergency planning reviews</li> </ol> <p>Reference Manual Bevi Risk Assessments version 3.2 (2009)</p> <p>CPR 18E (1999), Guideline for quantitative risk assessment ("Purple Book"), TNO Apeldoorn.</p> <p>CPR 14E (1997), Methods for the Calculation of Physical Effects ("Yellow Book"), 3<sup>rd</sup> Edition, TNO, Apeldoorn.</p> <p>CPR 16E (1992), Methods for the Determination of Possible Damage ("Green Book"), 1<sup>st</sup> Edition, TNO, Apeldoorn.</p> <p>Lees FP (2001), Loss Prevention in the Process Industries: Hazard Identification, Assessment and Control, 2<sup>nd</sup> Edition, Butterworths, London, UK.</p> <p>SANS 1461 SANS 31000 SANS 31010</p>

Original date of accreditation: 27 May 2005

Page 1 of 1

ISSUED BY THE SOUTH AFRICAN NATIONAL ACCREDITATION SYSTEM

  
Accreditation Manager

**16 APPENDIX E: MATERIAL SAFETY DATA SHEETS**

**16.1 Jet A-1 / Kerosene (UN No. 1863)**



# SAFETY DATA SHEET

## Jet A-1

Version 2.1

Revision Date 25.03.2024

Print Date 06.05.2024

### 1. IDENTIFICATION OF THE SUBSTANCE/MIXTURE AND OF THE COMPANY/UNDERTAKING

Product name : Jet A-1  
Product code : 002D7597

#### Manufacturer or supplier's details

Manufacturer/Supplier : **Shell Downstream South Africa (Pty) Ltd**  
The Campus  
Twickenham  
57 Sloane Street  
Bryanston  
2021  
South Africa

Telephone : (+27) 08604674355  
Telefax : (+27) 0214211308

Emergency telephone number : 011 608 3300 (including poison information).  
Netcare (for life-threatening emergencies) - 082 911.

#### Recommended use of the chemical and restrictions on use

Recommended use : Fuel for aviation turbine engines fitted to aircraft.

Restrictions on use : This product is not to be used as a solvent or cleaning agent; for lighting or brightening fires; as a skin cleanser., Not to be used as a fuel for automotive vehicles., Not to be used to prevent waxing in diesel fuel.  
This product must not be used in applications other than those listed in Section 1 without first seeking the advice of the supplier.

---

### 2. HAZARDS IDENTIFICATION

#### Classification (REGULATION (EC) No 1272/2008)

Flammable liquids : Category 3  
Aspiration hazard : Category 1  
Skin irritation : Category 2  
Acute toxicity (Inhalation) : Category 4  
Specific target organ toxicity - single exposure (Inhalation) : Category 3 (Narcotic effects)  
Carcinogenicity : Category 1B  
Specific target organ toxicity - repeated exposure : Category 2 (Blood, thymus, Liver)

# SAFETY DATA SHEET

## Jet A-1

Version 2.1

Revision Date 25.03.2024

Print Date 06.05.2024

Long-term (chronic) aquatic hazard : Category 2

### Label elements

Hazard pictograms :



Signal word : Danger

Hazard statements : **PHYSICAL HAZARDS:**  
H226 Flammable liquid and vapour.  
**HEALTH HAZARDS:**  
H304 May be fatal if swallowed and enters airways.  
H315 Causes skin irritation.  
H332 Harmful if inhaled.  
H336 May cause drowsiness or dizziness.  
H350 May cause cancer.  
H373 May cause damage to organs (Blood, Liver, thymus) through prolonged or repeated exposure.  
**ENVIRONMENTAL HAZARDS:**  
H411 Toxic to aquatic life with long lasting effects.

Precautionary statements : **Prevention:**  
P210 Keep away from heat, hot surfaces, sparks, open flames and other ignition sources. No smoking.  
P260 Do not breathe dust/ fume/ gas/ mist/ vapours/ spray.  
P273 Avoid release to the environment.  
P280 Wear protective gloves/ protective clothing/ eye protection/ face protection.  
**Response:**  
Do NOT induce vomiting.  
P301 + P310 IF SWALLOWED: Immediately call a POISON CENTER/ doctor.  
**Disposal:**  
P501 Dispose of contents/ container to an approved waste disposal plant.

### Other hazards

Slightly irritating to respiratory system. Liquid evaporates quickly and can ignite leading to a flash fire, or an explosion in a confined space. Vapour in the headspace of tanks and containers may ignite and explode at temperatures exceeding auto-ignition temperature, where vapour concentrations are within the flammability range. May ignite on surfaces at temperatures above auto-ignition temperature. This material is a static accumulator. Even with proper grounding and bonding, this material can still accumulate an electrostatic charge. If sufficient charge is allowed to accumulate, electrostatic discharge and ignition of flammable air-vapour mixtures can occur. Hydrogen sulphide (H<sub>2</sub>S), an extremely flammable and toxic gas, and other hazardous vapours may evolve and collect in the headspace of storage tanks, transport vessels and other enclosed containers.

# SAFETY DATA SHEET

## Jet A-1

Version 2.1

Revision Date 25.03.2024

Print Date 06.05.2024

### 3. COMPOSITION/INFORMATION ON INGREDIENTS

- Substance / Mixture : Mixture
- Chemical nature : Complex mixture of hydrocarbons consisting of paraffins, cycloparaffins, aromatic and olefinic hydrocarbons with carbon numbers predominantly in the C9 to C16 range.
- : May also contain several additives at <0.1% v/v each.

#### Hazardous components

Chemical name	CAS-No. EC-No. Registration number	Classification (REGULATION (EC) No 1272/2008)	Concentration (% w/w)
Distillates (petroleum), light hydrocracked	64741-77-1	Asp. Tox. 1; H304 Acute Tox. 4; H332 Skin Irrit. 2; H315 Carc. 2; H351 STOT RE 2; H373 Aquatic Chronic 2; H411	>= 0 - <= 100
kerosine (petroleum), sweetened	91770-15-9	Flam. Liq. 3; H226 Asp. Tox. 1; H304 Skin Irrit. 2; H315 STOT SE 3; H336 Carc. 1B; H350 Aquatic Chronic 2; H411	>= 0 - <= 100
kerosine (petroleum), hydrodesulfurized	64742-81-0	Flam. Liq. 3; H226 Skin Irrit. 2; H315 Asp. Tox. 1; H304 Carc. 1B; H350 Aquatic Chronic 2; H411	>= 0 - <= 100
Kerosine (petroleum)	8008-20-6	Flam. Liq. 3; H226 Skin Irrit. 2; H315 Asp. Tox. 1; H304 Carc. 1B; H350 Aquatic Chronic 2; H411	>= 0 - <= 100
Distillates (petroleum), hydrotreated light	64742-47-8	Asp. Tox. 1; H304 Carc. 1B; H350 Skin Irrit. 2; H315 STOT SE 3; H336	>= 0 - <= 100

Total aromatic hydrocarbons present are typically in the range of 10-20%v/v.

For explanation of abbreviations see section 16.

#### Further information

Contains:

Chemical name	Identification number	Concentration (% w/w)
---------------	-----------------------	-----------------------

# SAFETY DATA SHEET

## Jet A-1

Version 2.1

Revision Date 25.03.2024

Print Date 06.05.2024

Xylene, mixed isomers	1330-20-7	$\geq 0 - \leq 2$
Trimethylbenzene (all isomers)	25551-13-7	$\geq 0 - \leq 1$
Toluene	108-88-3	$\geq 0 - \leq 0,4$
Naphthalene	91-20-3	$\geq 0 - \leq 0,9$
Ethylbenzene	100-41-4	$\geq 0 - \leq 2$
Cumene	98-82-8	$\geq 0 - \leq 0,2$

### 4. FIRST-AID MEASURES

- General advice : Not expected to be a health hazard when used under normal conditions.
- If inhaled : Call emergency number for your location / facility.  
Remove to fresh air. Do not attempt to rescue the victim unless proper respiratory protection is worn. If the victim has difficulty breathing or tightness of the chest, is dizzy, vomiting, or unresponsive, give 100% oxygen with rescue breathing or Cardio-Pulmonary Resuscitation as required and transport to the nearest medical facility.
- In case of skin contact : Remove contaminated clothing. Immediately flush skin with large amounts of water for at least 15 minutes, and follow by washing with soap and water if available. If redness, swelling, pain and/or blisters occur, transport to the nearest medical facility for additional treatment.  
When using high pressure equipment, injection of product under the skin can occur. If high pressure injuries occur, the casualty should be sent immediately to a hospital. Do not wait for symptoms to develop.  
Obtain medical attention even in the absence of apparent wounds.
- In case of eye contact : Flush eye with copious quantities of water.  
Remove contact lenses, if present and easy to do. Continue rinsing.  
If persistent irritation occurs, obtain medical attention.
- If swallowed : Call emergency number for your location / facility.  
If swallowed, do not induce vomiting: transport to nearest medical facility for additional treatment. If vomiting occurs spontaneously, keep head below hips to prevent aspiration.  
If any of the following delayed signs and symptoms appear within the next 6 hours, transport to the nearest medical facility: fever greater than 101° F (38.3°C), shortness of breath, chest congestion or continued coughing or wheezing.
- Most important symptoms and effects, both acute and delayed : Respiratory irritation signs and symptoms may include a temporary burning sensation of the nose and throat, coughing, and/or difficulty breathing.  
Breathing of high vapour concentrations may cause central nervous system (CNS) depression resulting in dizziness, light-headedness, headache, nausea and loss of coordination.  
Continued inhalation may result in unconsciousness and

# SAFETY DATA SHEET

## Jet A-1

Version 2.1

Revision Date 25.03.2024

Print Date 06.05.2024

death.

Skin irritation signs and symptoms may include a burning sensation, redness, swelling, and/or blisters.

Local necrosis is evidenced by delayed onset of pain and tissue damage a few hours following injection.

Eye irritation signs and symptoms may include a burning sensation, redness, swelling, and/or blurred vision.

If material enters lungs, signs and symptoms may include coughing, choking, wheezing, difficulty in breathing, chest congestion, shortness of breath, and/or fever.

If any of the following delayed signs and symptoms appear within the next 6 hours, transport to the nearest medical facility: fever greater than 101° F (38.3°C), shortness of breath, chest congestion or continued coughing or wheezing.

Protection of first-aiders : When administering first aid, ensure that you are wearing the appropriate personal protective equipment according to the incident, injury and surroundings.

Notes to physician : IMMEDIATE TREATMENT IS EXTREMELY IMPORTANT!  
Call a doctor or poison control center for guidance.  
Treat symptomatically.  
Potential for chemical pneumonitis.  
Do not induce vomiting.  
High pressure injection injuries require prompt surgical intervention and possibly steroid therapy, to minimise tissue damage and loss of function.  
Because entry wounds are small and do not reflect the seriousness of the underlying damage, surgical exploration to determine the extent of involvement may be necessary. Local anaesthetics or hot soaks should be avoided because they can contribute to swelling, vasospasm and ischaemia. Prompt surgical decompression, debridement and evacuation of foreign material should be performed under general anaesthetics, and wide exploration is essential.

### 5. FIRE-FIGHTING MEASURES

Suitable extinguishing media : Foam, water spray or fog. Dry chemical powder, carbon dioxide, sand or earth may be used for small fires only.

Unsuitable extinguishing media : Do not use direct water jets on the burning product as they could cause a steam explosion and spread of the fire. Simultaneous use of foam and water on the same surface is to be avoided as water destroys the foam.

Specific hazards during firefighting : Hazardous combustion products may include:  
A complex mixture of airborne solid and liquid particulates and gases (smoke).  
Oxides of sulphur.  
Unidentified organic and inorganic compounds.  
Carbon monoxide may be evolved if incomplete combustion

# SAFETY DATA SHEET

## Jet A-1

Version 2.1

Revision Date 25.03.2024

Print Date 06.05.2024

occurs.

Will float and can be reignited on surface water.

Flammable vapours may be present even at temperatures below the flash point.

The vapour is heavier than air, spreads along the ground and distant ignition is possible.

Specific extinguishing methods

- : Use extinguishing measures that are appropriate to local circumstances and the surrounding environment.
- Keep adjacent containers cool by spraying with water.
- If possible remove containers from the danger zone.
- If the fire cannot be extinguished the only course of action is to evacuate immediately.
- Prevent fire extinguishing water from contaminating surface water or the ground water system.
- Contain residual material at affected sites to prevent material from entering drains (sewers), ditches, and waterways.

Special protective equipment for firefighters

- : Proper protective equipment including chemical resistant gloves are to be worn; chemical resistant suit is indicated if large contact with spilled product is expected. Self-Contained Breathing Apparatus must be worn when approaching a fire in a confined space. Select fire fighter's clothing approved to relevant Standards (e.g. Europe: EN469).

---

## 6. ACCIDENTAL RELEASE MEASURES

Personal precautions, protective equipment and emergency procedures

- : May ignite on surfaces at temperatures above auto-ignition temperature.
- Do not breathe fumes, vapour.
- Do not operate electrical equipment.
- : Shut off leaks, if possible without personal risks.
- Remove all possible sources of ignition in the surrounding area.
- Evacuate all personnel.
- Attempt to disperse vapour or to direct its flow to a safe location for example using fog sprays.
- Use appropriate containment to avoid environmental contamination. Prevent from spreading or entering drains, ditches or rivers by using sand, earth, or other appropriate barriers.

Environmental precautions

- : Prevent from spreading or entering into drains, ditches or rivers by using sand, earth, or other appropriate barriers.
- Take measures to minimise the effects on groundwater.
- Contain residual material at affected sites to prevent material from entering drains (sewers), ditches, and waterways.
- Do not allow contact with soil, surface or ground water.

Methods and materials for containment and cleaning up

- : Take precautionary measures against static discharges.
- For small liquid spills (< 1 drum), transfer by mechanical means to a labeled, sealable container for product recovery or

# SAFETY DATA SHEET

## Jet A-1

Version 2.1

Revision Date 25.03.2024

Print Date 06.05.2024

safe disposal. Allow residues to evaporate or soak up with an appropriate absorbent material and dispose of safely. Remove contaminated soil and dispose of safely.

For large liquid spills (> 1 drum), transfer by mechanical means such as vacuum truck to a salvage tank for recovery or safe disposal. Do not flush away residues with water. Retain as contaminated waste. Allow residues to evaporate or soak up with an appropriate absorbent material and dispose of safely. Remove contaminated soil and dispose of safely.

Avoid contact with skin, eyes and clothing.

Evacuate the area of all non-essential personnel.

Ventilate contaminated area thoroughly.

Take precautionary measures against static discharges.

Observe all relevant local and international regulations.

Additional advice : For guidance on selection of personal protective equipment see Section 8 of this Safety Data Sheet.  
Notify authorities if any exposure to the general public or the environment occurs or is likely to occur.  
For guidance on disposal of spilled material see Section 13 of this Safety Data Sheet.  
Local authorities should be advised if significant spillages cannot be contained.  
Maritime spillages should be dealt with using a Shipboard Oil Pollution Emergency Plan (SOPEP), as required by MARPOL Annex 1 Regulation 26.

## 7. HANDLING AND STORAGE

General Precautions : Avoid breathing of or direct contact with material. Only use in well ventilated areas. Wash thoroughly after handling. For guidance on selection of personal protective equipment see Section 8 of this Safety Data Sheet.  
Use the information in this data sheet as input to a risk assessment of local circumstances to help determine appropriate controls for safe handling, storage and disposal of this material.  
Air-dry contaminated clothing in a well-ventilated area before laundering.  
Contaminated leather articles including shoes cannot be decontaminated and should be destroyed to prevent reuse.  
Prevent spillages.  
Never siphon by mouth.

General Precautions Maintenance and Fuelling Activities - Avoid inhalation of vapours and contact with skin.

Advice on safe handling : Ensure that all local regulations regarding handling and storage facilities are followed.  
Extinguish any naked flames. Do not smoke. Remove ignition sources. Avoid sparks.  
Avoid inhaling vapour and/or mists.  
Avoid prolonged or repeated contact with skin.

# SAFETY DATA SHEET

## Jet A-1

Version 2.1

Revision Date 25.03.2024

Print Date 06.05.2024

When using do not eat or drink.

When handling product in drums, safety footwear should be worn and proper handling equipment should be used.

The vapour is heavier than air, spreads along the ground and distant ignition is possible.

Earth all equipment.

Use local exhaust ventilation if there is risk of inhalation of vapours, mists or aerosols.

Properly dispose of any contaminated rags or cleaning materials in order to prevent fires.

Avoidance of contact : Strong oxidising agents.

Product Transfer : Avoid splash filling Wait 2 minutes after tank filling (for tanks such as those on road tanker vehicles) before opening hatches or manholes. Wait 30 minutes after tank filling ( for large storage tanks) before opening hatches or manholes. Keep containers closed when not in use. Conditions, such as filling empty Filter Water Separator vessels, that lead to the formation of hydrocarbon mists are also particularly hazardous. Contamination resulting from product transfer may give rise to light hydrocarbon vapour in the headspace of tanks that have previously contained gasoline. This vapour may explode if there is a source of ignition. Partly filled containers present a greater hazard than those that are full, therefore handling, transfer and sampling activities need special care. Even with proper grounding and bonding, this material can still accumulate an electrostatic charge. If sufficient charge is allowed to accumulate, electrostatic discharge and ignition of flammable air-vapour mixtures can occur. Be aware of handling operations that may give rise to additional hazards that result from the accumulation of static charges. These include but are not limited to pumping (especially turbulent flow), mixing, filtering, splash filling, cleaning and filling of tanks and containers, sampling, switch loading, gauging, vacuum truck operations, and mechanical movements. These activities may lead to static discharge e.g. spark formation. Restrict line velocity during pumping in order to avoid generation of electrostatic discharge ( $\leq 1$  m/s until fill pipe submerged to twice its diameter, then  $\leq 7$  m/s). Avoid splash filling. Do NOT use compressed air for filling, discharging, or handling operations.

### Storage

Other data : Drum and small container storage:  
Drums should be stacked to a maximum of 3 high.  
Use properly labeled and closable containers.  
Take suitable precautions when opening sealed containers, as pressure can build up during storage.  
Tank storage:  
Tanks must be specifically designed for use with this product.  
Bulk storage tanks should be diked (bunded).  
Locate tanks away from heat and other sources of ignition.



# SAFETY DATA SHEET

## Jet A-1

Version 2.1

Revision Date 25.03.2024

Print Date 06.05.2024

The vapour is heavier than air. Beware of accumulation in pits and confined spaces.

Electrostatic charges will be generated during pumping. Electrostatic discharge may cause fire. Ensure electrical continuity by bonding and grounding (earthing) all equipment to reduce the risk.

The vapours in the head space of the storage vessel may lie in the flammable/explosive range and hence may be flammable.

Refer to section 15 for any additional specific legislation covering the packaging and storage of this product.

- Packaging material : Suitable material: For containers, or container linings use carbon steel and low alloy steel. Aluminium may also be used for applications where it does not present an unnecessary fire hazard. For container linings the following may also be used: Unplasticized polyvinyl chloride (U-PVC), Fluoropolymers (PTFE), Polyvinylidene fluoride (PVDF), Polyetheretherketone (PEEK), Polyamide (PA-11). For seals and gaskets use: Fluoroelastomer (FKM), Viton A, and Viton B, Nitrile butadiene (NBR), Buna-N. For coating (paint) materials use: High build, amine adduct-cured epoxy.
- Unsuitable material: For containers or container linings, examples of materials to avoid are: Polyethylene (PE, HDPE), Polypropylene (PP), Polymethyl methacrylate (PMMA), Acrylonitrile butadiene styrene (ABS). For seals and gaskets, examples of materials to avoid are: Natural rubber (NR), Ethylene Propylene (EPDM), Polychloroprene (CR) - Neoprene, Butyl (IIR), Chlorosulphonated polyethylene (CSM), e.g. Hypalon.
- Container Advice : Containers, even those that have been emptied, can contain explosive vapours. Do not cut, drill, grind, weld or perform similar operations on or near containers.
- Specific use(s) : Not applicable.
- See additional references that provide safe handling practices for liquids that are determined to be static accumulators: American Petroleum Institute 2003 (Protection Against Ignitions Arising out of Static, Lightning and Stray Currents) or National Fire Protection Agency 77 (Recommended Practices on Static Electricity).

## 8. EXPOSURE CONTROLS AND PERSONAL PROTECTION

### Components with workplace control parameters

Components	CAS-No.	Value type (Form of exposure)	Control parameters / Permissible concentration	Basis
Xylene, mixed isomers	1330-20-7	OEL- RL STEL/C	300 ppm	ZA OEL

# SAFETY DATA SHEET

## Jet A-1

Version 2.1

Revision Date 25.03.2024

Print Date 06.05.2024

	Further information: danger of cutaneous absorption, Occupational Exposure Limits - Restricted Limits For Hazardous Chemical Agents			
		OEL-RL	200 ppm	ZA OEL
	Further information: danger of cutaneous absorption, Occupational Exposure Limits - Restricted Limits For Hazardous Chemical Agents			
Trimethylbenzene (all isomers)	25551-13-7	OEL-RL	50 ppm	ZA OEL
	Further information: Occupational Exposure Limits - Restricted Limits For Hazardous Chemical Agents			
Toluene	108-88-3	OEL-RL	40 ppm	ZA OEL
	Further information: danger of cutaneous absorption, Occupational Exposure Limits - Restricted Limits For Hazardous Chemical Agents			
Naphthalene	91-20-3	OEL-RL	20 ppm	ZA OEL
	Further information: danger of cutaneous absorption, Occupational Exposure Limits - Restricted Limits For Hazardous Chemical Agents, denotes carcinogenicity, which is based on GHS categorisation, including category 1A, 1B			
Ethylbenzene	100-41-4	OEL-RL	40 ppm	ZA OEL
	Further information: danger of cutaneous absorption, Occupational Exposure Limits - Restricted Limits For Hazardous Chemical Agents, denotes carcinogenicity, which is based on GHS categorisation, including category 1A, 1B			
Cumene	98-82-8	OEL-RL	100 ppm	ZA OEL
	Further information: danger of cutaneous absorption, Occupational Exposure Limits - Restricted Limits For Hazardous Chemical Agents, denotes carcinogenicity, which is based on GHS categorisation, including category 1A, 1B			

### Biological occupational exposure limits

Component	CAS-No.	Control parameters	Biological specimen	Sampling time	Permissible concentration	Basis
Xylene, mixed isomers	1330-20-7	Methylhippuric acids	Urine	End of shift	1.5.g/g creatinine	ZA BEI
Toluene	108-88-3	Toluene	Blood	Prior to last shift of workweek	0,02 mg/l	ZA BEI
Toluene		Toluene	Urine	End of shift	0,03 mg/l	ZA BEI
Toluene		o-Cresol	Urine	End of shift	0.3.mg/g creatinine	ZA BEI
Remarks: Background. The determinant may be present in biological specimens collected from subjects who have not been occupationally exposed, at a concentration which could affect interpretation of the results. Such background concentrations are incorporated in the BEI value.						
Ethylbenzene	100-41-4	Sum of mandelic acid and phenylglyoxylic acid	Urine	End of shift	0.15.g/g creatinine	ZA BEI
Remarks: Non-specific. The determinant is non-specific, since it is also observed after exposure to						

# SAFETY DATA SHEET

## Jet A-1

Version 2.1

Revision Date 25.03.2024

Print Date 06.05.2024

other chemicals.

### Monitoring Methods

Monitoring of the concentration of substances in the breathing zone of workers or in the general workplace may be required to confirm compliance with an OEL and adequacy of exposure controls. For some substances biological monitoring may also be appropriate.

Validated exposure measurement methods should be applied by a competent person and samples analysed by an accredited laboratory.

Examples of sources of recommended exposure measurement methods are given below or contact the supplier. Further national methods may be available.

National Institute of Occupational Safety and Health (NIOSH), USA: Manual of Analytical Methods  
<http://www.cdc.gov/niosh/>

Occupational Safety and Health Administration (OSHA), USA: Sampling and Analytical Methods  
<http://www.osha.gov/>

Health and Safety Executive (HSE), UK: Methods for the Determination of Hazardous Substances  
<http://www.hse.gov.uk/>

Institut für Arbeitsschutz Deutschen Gesetzlichen Unfallversicherung (IFA) , Germany  
<http://www.dguv.de/inhalt/index.jsp>

L'Institut National de Recherche et de Sécurité, (INRS), France <http://www.inrs.fr/accueil>

### Engineering measures

- : The level of protection and types of controls necessary will vary depending upon potential exposure conditions. Select controls based on a risk assessment of local circumstances. Appropriate measures include:
  - Use sealed systems as far as possible.
  - Firewater monitors and deluge systems are recommended.
  - Adequate explosion-proof ventilation to control airborne concentrations below the exposure guidelines/limits.
  - Local exhaust ventilation is recommended.
  - Eye washes and showers for emergency use.

#### General Information:

Always observe good personal hygiene measures, such as washing hands after handling the material and before eating, drinking, and/or smoking. Routinely wash work clothing and protective equipment to remove contaminants. Discard contaminated clothing and footwear that cannot be cleaned. Practice good housekeeping.

Define procedures for safe handling and maintenance of controls.

Educate and train workers in the hazards and control measures relevant to normal activities associated with this product.

Ensure appropriate selection, testing and maintenance of equipment used to control exposure, e.g. personal protective equipment, local exhaust ventilation.

Drain down system prior to equipment break-in or maintenance.

Retain drain downs in sealed storage pending disposal or for subsequent recycle.

Do not ingest. If swallowed, then seek immediate medical assistance.

# SAFETY DATA SHEET

## Jet A-1

Version 2.1

Revision Date 25.03.2024

Print Date 06.05.2024

### Personal protective equipment

#### Protective measures

Personal protective equipment (PPE) should meet recommended national standards. Check with PPE suppliers.

Respiratory protection : If engineering controls do not maintain airborne concentrations to a level which is adequate to protect worker health, select respiratory protection equipment suitable for the specific conditions of use and meeting relevant legislation. Check with respiratory protective equipment suppliers. Where air-filtering respirators are unsuitable (e.g. airborne concentrations are high, risk of oxygen deficiency, confined space) use appropriate positive pressure breathing apparatus. Where air-filtering respirators are suitable, select an appropriate combination of mask and filter.

Select a filter suitable for the combination of organic gases and vapours and particles [Type A/Type P boiling point >65°C (149°F)].

Hand protection  
Remarks

: Where hand contact with the product may occur the use of gloves approved to relevant standards (e.g. Europe: EN374, US: F739) made from the following materials may provide suitable chemical protection. When prolonged or frequent repeated contact occurs. Nitrile rubber. For incidental contact/splash protection Neoprene, PVC gloves may be suitable. For continuous contact we recommend gloves with breakthrough time of more than 240 minutes with preference for > 480 minutes where suitable gloves can be identified. For short-term/splash protection we recommend the same but recognize that suitable gloves offering this level of protection may not be available and in this case a lower breakthrough time maybe acceptable so long as appropriate maintenance and replacement regimes are followed. Glove thickness is not a good predictor of glove resistance to a chemical as it is dependent on the exact composition of the glove material. Suitability and durability of a glove is dependent on usage, e.g. frequency and duration of contact, chemical resistance of glove material, dexterity. Always seek advice from glove suppliers. Contaminated gloves should be replaced. Personal hygiene is a key element of effective hand care. Gloves must only be worn on clean hands. After using gloves, hands should be washed and dried thoroughly. Application of a non-perfumed moisturizer is recommended.

Eye protection : Wear goggles for use against liquids and gas. If a local risk assessment deems it so then chemical splash goggles may not be required and safety glasses may provide adequate eye protection.

Skin and body protection : Wear chemical resistant gloves/gauntlets and boots. Where risk of splashing, also wear an apron. Wear antistatic and flame-retardant clothing, if a local risk

# SAFETY DATA SHEET

## Jet A-1

Version 2.1

Revision Date 25.03.2024

Print Date 06.05.2024

assessment deems it so.

Hygiene measures : In the interests of air safety, aviation fuels are subject to strict quality requirements and product integrity is of paramount importance. For one source of information on international standards for the quality assurance of aviation fuels, see [www.jjgonline.com](http://www.jjgonline.com).

### Environmental exposure controls

General advice : Local guidelines on emission limits for volatile substances must be observed for the discharge of exhaust air containing vapour.  
Minimise release to the environment. An environmental assessment must be made to ensure compliance with local environmental legislation.  
Information on accidental release measures are to be found in section 6.

## 9. PHYSICAL AND CHEMICAL PROPERTIES

Appearance : liquid

Colour : Colourless to light coloured

Odour : no data available

Odour Threshold : Data not available

pH : Not applicable

Melting point/freezing point : Data not available

Boiling point/boiling range : 150 - 300 °C / 302 - 572 °F  
Method: Unspecified

Flash point : 38 - 60 °C / 100 - 140 °F  
Method: Unspecified

Evaporation rate : Data not available

Flammability (solid, gas) : Not applicable

Upper explosion limit : 6 %(V)

Lower explosion limit : 1 %(V)

Vapour pressure : 1 - 3,7 kPa (38,0 °C / 100,4 °F)  
Method: Unspecified

1,6 - 7 kPa (50,0 °C / 122,0 °F)  
Method: Unspecified

Relative vapour density : Data not available

Relative density : Data not available

# SAFETY DATA SHEET

## Jet A-1

Version 2.1

Revision Date 25.03.2024

Print Date 06.05.2024

Density	: 775 - 840 kg/m <sup>3</sup> (15,0 °C / 59,0 °F) Method: Unspecified
	775 - 840 kg/m <sup>3</sup> (15,0 °C / 59,0 °F) Method: ASTM D4052
Solubility(ies)	
Water solubility	: negligible
Solubility in other solvents	: Data not available
Partition coefficient: n-octanol/water	: log Pow: 2 - 10
Auto-ignition temperature	: Data not available
Decomposition temperature	: Data not available
Viscosity	
Viscosity, dynamic	: Data not available
Viscosity, kinematic	: 1 - 2,5 mm <sup>2</sup> /s (38,0 °C / 100,4 °F) Method: Unspecified
Explosive properties	: Classification Code: Not classified.
Oxidizing properties	: Data not available
Conductivity	: Electrical conductivity: 50 - 600 pS/m., The conductivity of this material makes it a static accumulator., A liquid is typically considered nonconductive if its conductivity is below 100 pS/m and is considered semi-conductive if its conductivity is below 10,000 pS/m., Whether a liquid is nonconductive or semiconductive, the precautions are the same., A number of factors, for example liquid temperature, presence of contaminants, and anti-static additives can greatly influence the conductivity of a liquid
Particle size	: Data not available
	Data not available

---

### 10. STABILITY AND REACTIVITY

Reactivity	: Oxidises on contact with air.
Chemical stability	: No hazardous reaction is expected when handled and stored according to provisions
Possibility of hazardous	: No hazardous reaction is expected when handled and stored

# SAFETY DATA SHEET

## Jet A-1

Version 2.1

Revision Date 25.03.2024

Print Date 06.05.2024

reactions	according to provisions
Conditions to avoid	: Avoid heat, sparks, open flames and other ignition sources.  In certain circumstances product can ignite due to static electricity.
Incompatible materials	: Strong oxidising agents.
Hazardous decomposition products	: Hazardous decomposition products are not expected to form during normal storage. Thermal decomposition is highly dependent on conditions. A complex mixture of airborne solids, liquids and gases including carbon monoxide, carbon dioxide, sulphur oxides and unidentified organic compounds will be evolved when this material undergoes combustion or thermal or oxidative degradation.

### 11. TOXICOLOGICAL INFORMATION

Basis for assessment	: Information given is based on product data, a knowledge of the components and the toxicology of similar products. Unless indicated otherwise, the data presented is representative of the product as a whole, rather than for individual component(s).
Information on likely routes of exposure	: Exposure may occur via inhalation, ingestion, skin absorption, skin or eye contact, and accidental ingestion.

#### Acute toxicity

##### Product:

Acute oral toxicity	: LD 50 Rat: > 5.000 mg/kg Remarks: Low toxicity
Acute inhalation toxicity	: LC 50 Rat: > 5 mg/l Exposure time: 4 h Remarks: Harmful if inhaled.
Acute dermal toxicity	: LD 50 Rabbit: > 2.000 mg/kg Remarks: Low toxicity

##### Components:

##### **kerosine (petroleum), hydrodesulfurized:**

Acute oral toxicity	: LD 50 Rat: > 5.000 mg/kg Remarks: Low toxicity
Acute inhalation toxicity	: LC 50 Rat: > 5 mg/l Exposure time: 4 h Remarks: Low toxicity

# SAFETY DATA SHEET

## Jet A-1

Version 2.1

Revision Date 25.03.2024

Print Date 06.05.2024

Acute dermal toxicity : LD 50 Rabbit: > 2.000 mg/kg  
Remarks: Low toxicity

**Kerosine (petroleum):**

Acute oral toxicity : LD 50 Rat: > 5.000 mg/kg  
Remarks: Low toxicity

Acute inhalation toxicity : LC 50 Rat: > 5 mg/l  
Exposure time: 4 h  
Remarks: Low toxicity

Acute dermal toxicity : LD 50 Rabbit: > 2.000 mg/kg  
Remarks: Low toxicity

**Distillates (petroleum), hydrotreated light:**

Acute oral toxicity : LD50 Rat: > 5000 mg/kg  
Remarks: Low toxicity

Acute inhalation toxicity : LC50 Rat: 5 mg/l  
Exposure time: 4 h  
Remarks: Low toxicity

Acute dermal toxicity : LD50 Rabbit: > 5000 mg/kg  
Remarks: Low toxicity

### Skin corrosion/irritation

**Product:**

Remarks: Irritating to skin.

**Components:**

**kerosine (petroleum), hydrodesulfurized:**

Remarks: Irritating to skin.

**Kerosine (petroleum):**

Remarks: Irritating to skin.

**Distillates (petroleum), hydrotreated light:**

Remarks: Irritating to skin.

### Serious eye damage/eye irritation

**Product:**

Remarks: Slightly irritating to the eye., Based on available data, the classification criteria are not met.

**Components:**

**kerosine (petroleum), hydrodesulfurized:**



# SAFETY DATA SHEET

## Jet A-1

Version 2.1

Revision Date 25.03.2024

Print Date 06.05.2024

Remarks: Slightly irritating to the eye., Based on available data, the classification criteria are not met.

### **Kerosine (petroleum):**

Remarks: Slightly irritating to the eye., Based on available data, the classification criteria are not met.

### **Distillates (petroleum), hydrotreated light:**

Remarks: Not irritating to eye.

## **Respiratory or skin sensitisation**

### **Product:**

Remarks: Not a sensitiser.

Based on available data, the classification criteria are not met.

### **Components:**

#### **kerosine (petroleum), hydrodesulfurized:**

Remarks: Not a sensitiser.

Based on available data, the classification criteria are not met.

#### **Kerosine (petroleum):**

Remarks: Not a sensitiser.

Based on available data, the classification criteria are not met.

#### **Distillates (petroleum), hydrotreated light:**

Remarks: Not a sensitiser.

Based on available data, the classification criteria are not met.

## **Germ cell mutagenicity**

### **Product:**

Remarks: Non mutagenic, Based on available data, the classification criteria are not met.

### **Components:**

#### **kerosine (petroleum), hydrodesulfurized:**

Remarks: Non mutagenic, Based on available data, the classification criteria are not met.

#### **Kerosine (petroleum):**

Remarks: Non mutagenic, Based on available data, the classification criteria are not met.

#### **Distillates (petroleum), hydrotreated light:**

Remarks: Not mutagenic.

Germ cell mutagenicity-  
Assessment

: This product does not meet the criteria for classification in categories 1A/1B.

## **Carcinogenicity**

### **Product:**

# SAFETY DATA SHEET

## Jet A-1

Version 2.1

Revision Date 25.03.2024

Print Date 06.05.2024

Remarks: Limited evidence of carcinogenic effect

### Components:

#### **Kerosine (petroleum):**

Remarks: Not classified as a carcinogen.

Remarks: Repeated skin contact has resulted in irritation and skin cancer in animals.

#### **Distillates (petroleum), hydrotreated light:**

Carcinogenicity - Assessment : This product does not meet the criteria for classification in categories 1A/1B.

Material	GHS/CLP Carcinogenicity Classification
Distillates (petroleum), light hydrocracked	CarcinogenicityCategory 2
Xylene, mixed isomers	No carcinogenicity classification.
kerosine (petroleum), sweetened	No carcinogenicity classification.
Trimethylbenzene (all isomers)	No carcinogenicity classification.
kerosine (petroleum), hydrodesulfurized	No carcinogenicity classification.
Toluene	No carcinogenicity classification.
Kerosine (petroleum)	No carcinogenicity classification.
Naphthalene	CarcinogenicityCategory 2
Ethylbenzene	No carcinogenicity classification.
Cumene	No carcinogenicity classification.
Distillates (petroleum), hydrotreated light	No carcinogenicity classification.

Material	Other Carcinogenicity Classification
Distillates (petroleum), light hydrocracked	IARC: Group 3: Not classifiable as to its carcinogenicity to humans
Xylene, mixed isomers	IARC: Group 3: Not classifiable as to its carcinogenicity to humans
kerosine (petroleum), sweetened	IARC: Group 3: Not classifiable as to its carcinogenicity to humans
kerosine (petroleum), hydrodesulfurized	IARC: Group 3: Not classifiable as to its carcinogenicity to humans
Toluene	IARC: Group 3: Not classifiable as to its carcinogenicity to

# SAFETY DATA SHEET

## Jet A-1

Version 2.1

Revision Date 25.03.2024

Print Date 06.05.2024

	humans
Kerosine (petroleum)	IARC: Group 3: Not classifiable as to its carcinogenicity to humans
Naphthalene	IARC: Group 2B: Possibly carcinogenic to humans
Ethylbenzene	IARC: Group 2B: Possibly carcinogenic to humans
Cumene	IARC: Group 2B: Possibly carcinogenic to humans
Distillates (petroleum), hydrotreated light	IARC: Group 3: Not classifiable as to its carcinogenicity to humans

### Reproductive toxicity

#### Product:

Remarks: Not a developmental toxicant., Based on available data, the classification criteria are not met., Does not impair fertility.

#### Components:

##### kerosine (petroleum), hydrodesulfurized:

Remarks: Does not impair fertility., Not a developmental toxicant., Based on available data, the classification criteria are not met.

##### Kerosine (petroleum):

Remarks: Does not impair fertility., Not a developmental toxicant., Based on available data, the classification criteria are not met.

##### Distillates (petroleum), hydrotreated light:

Remarks: Does not impair fertility., Not a developmental toxicant., Based on available data, the classification criteria are not met.

Reproductive toxicity -  
Assessment

: This product does not meet the criteria for classification in categories 1A/1B.

### STOT - single exposure

#### Product:

Remarks: High concentrations may cause central nervous system depression resulting in headaches, dizziness and nausea; continued inhalation may result in unconsciousness and/or death., Inhalation of vapours or mists may cause irritation to the respiratory system.

#### Components:

# SAFETY DATA SHEET

## Jet A-1

Version 2.1

Revision Date 25.03.2024

Print Date 06.05.2024

### **kerosine (petroleum), hydrodesulfurized:**

Remarks: High concentrations may cause central nervous system depression resulting in headaches, dizziness and nausea; continued inhalation may result in unconsciousness.

### **Kerosine (petroleum):**

Remarks: High concentrations may cause central nervous system depression resulting in headaches, dizziness and nausea; continued inhalation may result in unconsciousness.

### **Distillates (petroleum), hydrotreated light:**

Remarks: High concentrations may cause central nervous system depression resulting in headaches, dizziness and nausea; continued inhalation may result in unconsciousness.

## **STOT - repeated exposure**

### **Product:**

Remarks: May cause damage to organs or organ systems through prolonged or repeated exposure.

Target Organs: Blood

Remarks: Blood: may cause haemolysis of red blood cells and/or anaemia.

Target Organs: Liver

Remarks: Liver: can cause liver damage.

Target Organs: thymus

### **Components:**

#### **kerosine (petroleum), hydrodesulfurized:**

Remarks: Kidney: caused kidney effects in male rats which are not considered relevant to humans

#### **Kerosine (petroleum):**

Remarks: Kidney: caused kidney effects in male rats which are not considered relevant to humans

#### **Distillates (petroleum), hydrotreated light:**

Remarks: Kidney: caused kidney effects in male rats which are not considered relevant to humans

## **Aspiration toxicity**

### **Product:**

Aspiration into the lungs when swallowed or vomited may cause chemical pneumonitis which can be fatal.

### **Components:**

#### **kerosine (petroleum), hydrodesulfurized:**

Aspiration into the lungs when swallowed or vomited may cause chemical pneumonitis which can be fatal.

# SAFETY DATA SHEET

## Jet A-1

Version 2.1

Revision Date 25.03.2024

Print Date 06.05.2024

### **Kerosine (petroleum):**

Aspiration into the lungs when swallowed or vomited may cause chemical pneumonitis which can be fatal.

### **Distillates (petroleum), hydrotreated light:**

Aspiration into the lungs when swallowed or vomited may cause chemical pneumonitis which can be fatal.

## **Further information**

### **Product:**

Remarks: Classifications by other authorities under varying regulatory frameworks may exist.

### **Components:**

#### **kerosine (petroleum), hydrodesulfurized:**

Remarks: Classifications by other authorities under varying regulatory frameworks may exist.

#### **Kerosine (petroleum):**

Remarks: Classifications by other authorities under varying regulatory frameworks may exist.

#### **Distillates (petroleum), hydrotreated light:**

Remarks: Classifications by other authorities under varying regulatory frameworks may exist.

---

## **12. ECOLOGICAL INFORMATION**

Basis for assessment : Fuels are typically made from blending several refinery streams. Ecotoxicological studies have been carried out on a variety of hydrocarbon blends and streams but not those containing additives.  
Information given is based on a knowledge of the components and the ecotoxicology of similar products. Unless indicated otherwise, the data presented is representative of the product as a whole, rather than for individual component(s).

### **Ecotoxicity**

#### **Product:**

Toxicity to fish (Acute toxicity) :  
Remarks: Toxic  
LL/EL/IL50 > 1 <= 10 mg/l

Toxicity to crustacean (Acute toxicity) :  
Remarks: Toxic  
LL/EL/IL50 > 1 <= 10 mg/l

Toxicity to algae/aquatic plants (Acute toxicity) :  
Remarks: Toxic  
LL/EL/IL50 > 1 <= 10 mg/l

# SAFETY DATA SHEET

## Jet A-1

Version 2.1

Revision Date 25.03.2024

Print Date 06.05.2024

Toxicity to fish (Chronic toxicity) : Remarks: NOEC/NOEL > 0.01 - <=0.1 mg/l  
Toxicity to crustacean (Chronic toxicity) : Remarks: NOEC/NOEL > 0.1 - <=1.0 mg/l  
Toxicity to microorganisms (Acute toxicity) : Remarks: Practically non toxic:  
LL/EL/IL50 > 100 mg/l

### **Components:**

#### **kerosine (petroleum), hydrodesulfurized :**

Toxicity to fish (Acute toxicity) : Remarks: Toxic  
LL/EL/IL50 > 1 <= 10 mg/l  
Toxicity to crustacean (Acute toxicity) : Remarks: Toxic  
LL/EL/IL50 > 1 <= 10 mg/l  
Toxicity to algae/aquatic plants (Acute toxicity) : Remarks: Toxic  
LL/EL/IL50 > 1 <= 10 mg/l  
Toxicity to microorganisms (Acute toxicity) : Remarks: Practically non toxic:  
LL/EL/IL50 > 100 mg/l  
Toxicity to fish (Chronic toxicity) : Remarks: NOEC/NOEL > 0.01 - <=0.1 mg/l  
Toxicity to crustacean(Chronic toxicity) : Remarks: NOEC/NOEL > 0.1 - <=1.0 mg/l

#### **Kerosine (petroleum) :**

Toxicity to fish (Acute toxicity) : Remarks: Toxic  
LL/EL/IL50 > 1 <= 10 mg/l  
Toxicity to crustacean (Acute toxicity) : Remarks: Toxic  
LL/EL/IL50 > 1 <= 10 mg/l  
Toxicity to algae/aquatic plants (Acute toxicity) : Remarks: Toxic  
LL/EL/IL50 > 1 <= 10 mg/l  
Toxicity to microorganisms (Acute toxicity) : Remarks: Practically non toxic:  
LL/EL/IL50 > 100 mg/l  
Toxicity to fish (Chronic toxicity) : Remarks: NOEC/NOEL > 0.01 - <=0.1 mg/l  
Toxicity to crustacean(Chronic toxicity) : Remarks: NOEC/NOEL > 0.1 - <=1.0 mg/l

#### **Distillates (petroleum), hydrotreated light :**

Toxicity to fish (Acute toxicity) : Remarks: Practically non toxic:  
LL/EL/IL50 > 100 mg/l  
Toxicity to crustacean (Acute toxicity) : Remarks: Practically non toxic:  
LL/EL/IL50 > 100 mg/l  
Toxicity to algae/aquatic plants (Acute toxicity) : Remarks: Practically non toxic:  
LL/EL/IL50 > 100 mg/l  
Toxicity to microorganisms : Remarks: Data not available

# SAFETY DATA SHEET

## Jet A-1

Version 2.1

Revision Date 25.03.2024

Print Date 06.05.2024

(Acute toxicity)

Toxicity to fish (Chronic toxicity) : Remarks: Data not available

Toxicity to crustacean(Chronic toxicity) : Remarks: Data not available

### Persistence and degradability

#### Product:

Biodegradability : Remarks: Major constituents are inherently biodegradable, but contains components that may persist in the environment., The volatile constituents will oxidize rapidly by photochemical reactions in air., Based on available data, the classification criteria are not met., Not Persistent per IMO criteria., International Oil Pollution Compensation (IOPC) Fund definition: "A non-persistent oil is oil, which, at the time of shipment, consists of hydrocarbon fractions, (a) at least 50% of which, by volume, distills at a temperature of 340°C (645°F) and (b) at least 95% of which, by volume, distills at a temperature of 370°C (700°F) when tested by the ASTM Method D-86/78 or any subsequent revision thereof."

#### Components:

##### **kerosine (petroleum), hydrodesulfurized :**

Biodegradability : Remarks: Major constituents are inherently biodegradable, but contains components that may persist in the environment. The volatile constituents will oxidize rapidly by photochemical reactions in air. Based on available data, the classification criteria are not met. Not Persistent per IMO criteria. International Oil Pollution Compensation (IOPC) Fund definition: "A non-persistent oil is oil, which, at the time of shipment, consists of hydrocarbon fractions, (a) at least 50% of which, by volume, distills at a temperature of 340°C (645°F) and (b) at least 95% of which, by volume, distills at a temperature of 370°C (700°F) when tested by the ASTM Method D-86/78 or any subsequent revision thereof."

##### **Kerosine (petroleum) :**

Biodegradability : Remarks: Major constituents are inherently biodegradable, but contains components that may persist in the environment. The volatile constituents will oxidize rapidly by photochemical reactions in air. Based on available data, the classification criteria are not met. Not Persistent per IMO criteria. International Oil Pollution Compensation (IOPC) Fund definition: "A non-persistent oil is oil, which, at the time of shipment, consists of hydrocarbon fractions, (a) at least 50% of which, by volume, distills at a temperature of 340°C (645°F) and (b) at least 95% of which, by volume, distills at a temperature of 370°C (700°F) when tested by the ASTM Method D-86/78 or any subsequent revision thereof."

##### **Distillates (petroleum), hydrotreated light :**

Biodegradability : Remarks: Readily biodegradable.

# SAFETY DATA SHEET

## Jet A-1

Version 2.1

Revision Date 25.03.2024

Print Date 06.05.2024

Oxidises rapidly by photo-chemical reactions in air.  
Not Persistent per IMO criteria.  
International Oil Pollution Compensation (IOPC) Fund definition: "A non-persistent oil is oil, which, at the time of shipment, consists of hydrocarbon fractions, (a) at least 50% of which, by volume, distills at a temperature of 340°C (645°F) and (b) at least 95% of which, by volume, distils at a temperature of 370°C (700°F) when tested by the ASTM Method D-86/78 or any subsequent revision thereof."

### Bioaccumulative potential

#### Product:

Bioaccumulation : Remarks: Contains constituents with the potential to bioaccumulate.

Partition coefficient: n-octanol/water : log Pow: 2 - 10

#### Components:

##### **kerosine (petroleum), hydrodesulfurized :**

Bioaccumulation : Remarks: Contains constituents with the potential to bioaccumulate.

##### **Kerosine (petroleum) :**

Bioaccumulation : Remarks: Contains constituents with the potential to bioaccumulate.

##### **Distillates (petroleum), hydrotreated light :**

Bioaccumulation : Remarks: Has the potential to bioaccumulate.

### Mobility in soil

#### Product:

Mobility : Remarks: Evaporates within a day from water or soil surfaces., Large volumes may penetrate soil and could contaminate groundwater., Contains volatile components., Floats on water.

#### Components:

##### **kerosine (petroleum), hydrodesulfurized :**

Mobility : Remarks: Evaporates within a day from water or soil surfaces., Large volumes may penetrate soil and could contaminate groundwater., Contains volatile components., Floats on water.

##### **Kerosine (petroleum) :**

Mobility : Remarks: Evaporates within a day from water or soil surfaces., Large volumes may penetrate soil and could contaminate groundwater., Contains volatile components., Floats on water.

##### **Distillates (petroleum), hydrotreated light :**

Mobility : Remarks: Floats on water., If it enters soil, it will adsorb to soil particles and will not be mobile.

### Other adverse effects

#### Product:

Results of PBT and vPvB : This mixture does not contain any REACH registered



# SAFETY DATA SHEET

## Jet A-1

Version 2.1

Revision Date 25.03.2024

Print Date 06.05.2024

assessment : substances that are assessed to be a PBT or a vPvB.  
Additional ecological information : Films formed on water may affect oxygen transfer and damage organisms.

### Components:

#### **kerosine (petroleum), hydrodesulfurized :**

Results of PBT and vPvB assessment : This mixture does not contain any REACH registered substances that are assessed to be a PBT or a vPvB.  
Additional ecological information : Films formed on water may affect oxygen transfer and damage organisms.

#### **Kerosine (petroleum) :**

Results of PBT and vPvB assessment : This mixture does not contain any REACH registered substances that are assessed to be a PBT or a vPvB.  
Additional ecological information : Films formed on water may affect oxygen transfer and damage organisms.

## 13. DISPOSAL CONSIDERATIONS

### **Disposal methods**

Waste from residues : Recover or recycle if possible.  
It is the responsibility of the waste generator to determine the toxicity and physical properties of the material generated to determine the proper waste classification and disposal methods in compliance with applicable regulations.  
Do not dispose into the environment, in drains or in water courses.  
Do not dispose of tank water bottoms by allowing them to drain into the ground. This will result in soil and groundwater contamination.  
Waste arising from a spillage or tank cleaning should be disposed of in accordance with prevailing regulations, preferably to a recognised collector or contractor. The competence of the collector or contractor should be established beforehand.

MARPOL - see International Convention for the Prevention of Pollution from Ships (MARPOL 73/78) which provides technical aspects at controlling pollutions from ships.

Contaminated packaging : Send to drum recoverer or metal reclaimer.  
Drain container thoroughly.  
After draining, vent in a safe place away from sparks and fire.  
Residues may cause an explosion hazard if heated above the flash point. Do not puncture, cut or weld uncleaned drums.  
Do not pollute the soil, water or environment with the waste container.  
Comply with any local recovery or waste disposal regulations.

Local legislation  
Remarks : Disposal should be in accordance with applicable regional, national, and local laws and regulations.  
Local regulations may be more stringent than regional or

# SAFETY DATA SHEET

## Jet A-1

Version 2.1

Revision Date 25.03.2024

Print Date 06.05.2024

national requirements and must be complied with.

---

### 14. TRANSPORT INFORMATION

#### International Regulations

##### ADR

UN number : 1863  
Proper shipping name : FUEL, AVIATION, TURBINE ENGINE  
Class : 3  
Packing group : III  
Labels : 3  
Hazard Identification Number : 30  
Environmentally hazardous : yes

##### IATA-DGR

UN/ID No. : UN 1863  
Proper shipping name : FUEL, AVIATION, TURBINE ENGINE  
Class : 3  
Packing group : III  
Labels : 3

##### IMDG-Code

UN number : UN 1863  
Proper shipping name : FUEL, AVIATION, TURBINE ENGINE  
Class : 3  
Packing group : III  
Labels : 3  
Marine pollutant : yes

#### Maritime transport in bulk according to IMO instruments

MARPOL Annex 1 rules apply for bulk shipments by sea.

#### Special precautions for user

Remarks : Special Precautions: Refer to Section 7, Handling & Storage, for special precautions which a user needs to be aware of or needs to comply with in connection with transport.

---

### 15. REGULATORY INFORMATION

#### Safety, health and environmental regulations/legislation specific for the substance or mixture

The regulatory information is not intended to be comprehensive. Other regulations may apply to this material.

# SAFETY DATA SHEET

## Jet A-1

Version 2.1

Revision Date 25.03.2024

Print Date 06.05.2024

### 16. OTHER INFORMATION

#### Full text of H-Statements

H226	Flammable liquid and vapour.
H304	May be fatal if swallowed and enters airways.
H315	Causes skin irritation.
H332	Harmful if inhaled.
H336	May cause drowsiness or dizziness.
H350	May cause cancer.
H351	Suspected of causing cancer.
H373	May cause damage to organs through prolonged or repeated exposure.
H411	Toxic to aquatic life with long lasting effects.

#### Full text of other abbreviations

Acute Tox.	Acute toxicity
Aquatic Chronic	Long-term (chronic) aquatic hazard
Asp. Tox.	Aspiration hazard
Carc.	Carcinogenicity
Flam. Liq.	Flammable liquids
Skin Irrit.	Skin irritation
STOT RE	Specific target organ toxicity - repeated exposure
STOT SE	Specific target organ toxicity - single exposure

Abbreviations and Acronyms : The standard abbreviations and acronyms used in this document can be looked up in reference literature (e.g. scientific dictionaries) and/or websites.

SDS Regulation : Regulation 1907/2006/EC

#### Further information

Training advice :  
Provide adequate information, instruction and training for operators.

Other information : This product is intended for use in closed systems only.  
A vertical bar (|) in the left margin indicates an amendment from the previous version.

Sources of key data used to compile the Safety Data Sheet :  
The quoted data are from, but not limited to, one or more sources of information (e.g. toxicological data from Shell Health Services, material suppliers' data, CONCAWE, EU IUCLID data base, EC 1272 regulation, etc).

# SAFETY DATA SHEET

## Jet A-1

Version 2.1

Revision Date 25.03.2024

Print Date 06.05.2024

---

This information is based on our current knowledge and is intended to describe the product for the purposes of health, safety and environmental requirements only. It should not therefore be construed as guaranteeing any specific property of the product.

## **16.2 Avgas (UN No. 1203)**

# SAFETY DATA SHEET

## AVGAS 100LL

Version 7.1

Revision Date 10.05.2024

Print Date 11.05.2024

### 1. IDENTIFICATION OF THE SUBSTANCE/MIXTURE AND OF THE COMPANY/UNDERTAKING

Product name : AVGAS 100LL

Product code : 002D0717

#### Manufacturer or supplier's details

Manufacturer/Supplier : **Shell Downstream South Africa (Pty) Ltd**  
The Campus  
Twickenham  
57 Sloane Street  
Bryanston  
2021  
South Africa

Telephone : (+27) 08604674355

Telefax : (+27) 0214211308

Emergency telephone number : 011 608 3300 (including poison information).  
Netcare (for life-threatening emergencies) - 082 911.

#### Recommended use of the chemical and restrictions on use

Recommended use : Aviation Fuel, Low lead content aviation gasoline fuel for piston engined aircraft

Restrictions on use :  
This product must not be used in applications other than those listed in Section 1 without first seeking the advice of the supplier.

---

### 2. HAZARDS IDENTIFICATION

#### Classification (REGULATION (EC) No 1272/2008)

Flammable liquids : Category 1  
Aspiration hazard : Category 1  
Skin irritation : Category 2  
Specific target organ toxicity - single exposure (Inhalation) : Category 3 (Narcotic effects)  
Carcinogenicity : Category 1B  
Reproductive toxicity : Category 2  
Specific target organ toxicity - repeated exposure : Category 2 (Liver, Kidney, Brain)  
Long-term (chronic) aquatic hazard : Category 2

# SAFETY DATA SHEET

## AVGAS 100LL

Version 7.1

Revision Date 10.05.2024

Print Date 11.05.2024

### Label elements

Hazard pictograms



Signal word

: Danger

Hazard statements

: **PHYSICAL HAZARDS:**  
H224 Extremely flammable liquid and vapour.  
**HEALTH HAZARDS:**  
H304 May be fatal if swallowed and enters airways.  
H315 Causes skin irritation.  
H336 May cause drowsiness or dizziness.  
H350 May cause cancer.  
H361d Suspected of damaging the unborn child.  
H373 May cause damage to organs through prolonged or repeated exposure.  
**ENVIRONMENTAL HAZARDS:**  
H411 Toxic to aquatic life with long lasting effects.

Precautionary statements

: **Prevention:**  
P260 Do not breathe dust/ fume/ gas/ mist/ vapours/ spray.  
P210 Keep away from heat, hot surfaces, sparks, open flames and other ignition sources. No smoking.  
P280 Wear protective gloves/ protective clothing/ eye protection/ face protection.  
**Response:**  
P331 Do NOT induce vomiting.  
P301 + P310 IF SWALLOWED: Immediately call a POISON CENTER/ doctor.  
**Storage:**  
P403 Store in a well-ventilated place.  
**Disposal:**  
P501 Dispose of contents/ container to an approved waste disposal plant.

### Other hazards

Liquid evaporates quickly and can ignite leading to a flash fire, or an explosion in a confined space. This material is a static accumulator. Even with proper grounding and bonding, this material can still accumulate an electrostatic charge. If sufficient charge is allowed to accumulate, electrostatic discharge and ignition of flammable air-vapour mixtures can occur. Electrostatic charges may be generated during pumping. Electrostatic discharge may cause fire. This product contains tetraethyl lead which is known to accumulate in the human body. There are indications from human epidemiological studies that exposure to tetraethyl lead may cause developmental and neurobehavioral effects in the unborn child.

### 3. COMPOSITION/INFORMATION ON INGREDIENTS

Substance / Mixture

: Mixture

Chemical nature

: Complex mixture of hydrocarbons consisting of paraffins, cycloparaffins, aromatic and olefinic hydrocarbons with carbon

# SAFETY DATA SHEET

## AVGAS 100LL

Version 7.1

Revision Date 10.05.2024

Print Date 11.05.2024

numbers predominantly in the C4 to C12 range.  
May also contain several additives at <0.1% v/v each.  
This product is dyed for grade identification.  
Contains Tetraethyl lead, CAS # 78-00-2

### Hazardous components

Chemical name	CAS-No. EC-No. Registration number	Classification (REGULATION (EC) No 1272/2008)	Concentration (% w/w)
Gasoline	86290-81-5	Flam. Liq. 1; H224 Asp. Tox. 1; H304 Carc. 1B; H350 Skin Irrit. 2; H315 STOT SE 3; H336 Repr. 2; H361d Aquatic Chronic 2; H411	99,88 - 99,94
Tetraethyl lead	78-00-2	Repr. 1A; H360Df Acute Tox. 2; H330 Acute Tox. 1; H310 Acute Tox. 2; H300 STOT RE 2; H373 Aquatic Acute 1; H400 Aquatic Chronic 1; H410	>= 0,06 - <= 0,12

For explanation of abbreviations see section 16.

### Further information

Contains:

Chemical name	Identification number	Concentration (% w/w)
n-Hexane	110-54-3	>= 0 - <= 0,5
Xylene, mixed isomers	1330-20-7	>= 12 - <= 15
Benzene	71-43-2	>= 0 - <= 0,09
Cumene	98-82-8	>= 0 - <= 0,25
Toluene	108-88-3	>= 12 - <= 15
Cyclohexane	110-82-7	>= 0 - <= 0,05
Ethylbenzene	100-41-4	>= 0 - <= 2,5
Trimethylbenzene (all isomers)	25551-13-7	>= 0 - <= 0,5
Naphthalene	91-20-3	>= 0 - <= 0,05

## 4. FIRST-AID MEASURES

If inhaled : Remove to fresh air. If rapid recovery does not occur, transport to nearest medical facility for additional treatment.



# SAFETY DATA SHEET

## AVGAS 100LL

Version 7.1

Revision Date 10.05.2024

Print Date 11.05.2024

- 
- |                                                             |                                                                                                                                                                                                                                                                                                                                                                                                                                                                                                                                                                                                                                                    |
|-------------------------------------------------------------|----------------------------------------------------------------------------------------------------------------------------------------------------------------------------------------------------------------------------------------------------------------------------------------------------------------------------------------------------------------------------------------------------------------------------------------------------------------------------------------------------------------------------------------------------------------------------------------------------------------------------------------------------|
| In case of skin contact                                     | : Remove contaminated clothing.                                                                                                                                                                                                                                                                                                                                                                                                                                                                                                                                                                                                                    |
| In case of eye contact                                      | : Immediately flush eye(s) with plenty of water.<br>Remove contact lenses, if present and easy to do. Continue rinsing.<br>Transport to the nearest medical facility for additional treatment.                                                                                                                                                                                                                                                                                                                                                                                                                                                     |
| If swallowed                                                | : If swallowed, do not induce vomiting: transport to nearest medical facility for additional treatment. If vomiting occurs spontaneously, keep head below hips to prevent aspiration. Rinse mouth.<br>Call emergency number for your location / facility.<br>If any of the following delayed signs and symptoms appear within the next 6 hours, transport to the nearest medical facility: fever greater than 101° F (38.3°C), shortness of breath, chest congestion or continued coughing or wheezing.                                                                                                                                            |
| Most important symptoms and effects, both acute and delayed | : Skin irritation signs and symptoms may include a burning sensation, redness, swelling, and/or blisters.<br>Eye irritation signs and symptoms may include a burning sensation, redness, swelling, and/or blurred vision.<br>If material enters lungs, signs and symptoms may include coughing, choking, wheezing, difficulty in breathing, chest congestion, shortness of breath, and/or fever.<br>The onset of respiratory symptoms may be delayed for several hours after exposure.<br>Breathing of high vapour concentrations may cause central nervous system (CNS) depression resulting in dizziness, light-headedness, headache and nausea. |
| Protection of first-aiders                                  | : When administering first aid, ensure that you are wearing the appropriate personal protective equipment according to the incident, injury and surroundings.                                                                                                                                                                                                                                                                                                                                                                                                                                                                                      |
| Notes to physician                                          | : Treat symptomatically.<br>Persons on disulfiram (Antabuse®) therapy should be aware that the ethyl alcohol in this product is hazardous to them just as is alcohol from any source. Disulfiram reactions (vomiting, headache and even collapse) may follow ingestion of small amounts of alcohol and have also been described from skin contact.                                                                                                                                                                                                                                                                                                 |

---

### 5. FIRE-FIGHTING MEASURES

- |                                |                                                                                                                                                                                                                         |
|--------------------------------|-------------------------------------------------------------------------------------------------------------------------------------------------------------------------------------------------------------------------|
| Suitable extinguishing media   | : Foam, water spray or fog. Dry chemical powder, carbon dioxide, sand or earth may be used for small fires only.                                                                                                        |
| Unsuitable extinguishing media | : Do not use direct water jets on the burning product as they could cause a steam explosion and spread of the fire. Simultaneous use of foam and water on the same surface is to be avoided as water destroys the foam. |

# SAFETY DATA SHEET

## AVGAS 100LL

Version 7.1

Revision Date 10.05.2024

Print Date 11.05.2024

- Specific hazards during firefighting : Clear fire area of all non-emergency personnel.  
Hazardous combustion products may include:  
A complex mixture of airborne solid and liquid particulates and gases (smoke).  
Carbon monoxide may be evolved if incomplete combustion occurs.  
Unidentified organic and inorganic compounds.  
The vapour is heavier than air, spreads along the ground and distant ignition is possible.  
Will float and can be reignited on surface water.
- Specific extinguishing methods : Use extinguishing measures that are appropriate to local circumstances and the surrounding environment.  
Keep adjacent containers cool by spraying with water.  
If possible remove containers from the danger zone.  
If the fire cannot be extinguished the only course of action is to evacuate immediately.  
Prevent fire extinguishing water from contaminating surface water or the ground water system.  
Contain residual material at affected sites to prevent material from entering drains (sewers), ditches, and waterways.
- Special protective equipment for firefighters : Proper protective equipment including chemical resistant gloves are to be worn; chemical resistant suit is indicated if large contact with spilled product is expected. Self-Contained Breathing Apparatus must be worn when approaching a fire in a confined space. Select fire fighter's clothing approved to relevant Standards (e.g. Europe: EN469).

---

### 6. ACCIDENTAL RELEASE MEASURES

- Personal precautions, protective equipment and emergency procedures : Vapour can travel for considerable distances both above and below the ground surface. Underground services (drains, pipelines, cable ducts) can provide preferential flow paths.  
Do not breathe fumes, vapour.  
Take measures to minimise the effects on groundwater.  
Contain residual material at affected sites to prevent material from entering drains (sewers), ditches, and waterways.
- : Avoid contact with skin, eyes and clothing.
- : Shut off leaks, if possible without personal risks.  
Remove all possible sources of ignition in the surrounding area.  
Evacuate all personnel.  
Attempt to disperse the vapour or to direct its flow to a safe location, for example by using fog sprays.  
Vapour can travel for considerable distances both above and below the ground surface. Underground services (drains, pipelines, cable ducts) can provide preferential flow paths.
- Environmental precautions : Take measures to minimise the effects on groundwater.

# SAFETY DATA SHEET

## AVGAS 100LL

Version 7.1

Revision Date 10.05.2024

Print Date 11.05.2024

Contain residual material at affected sites to prevent material from entering drains (sewers), ditches, and waterways. Prevent from spreading or entering into drains, ditches or rivers by using sand, earth, or other appropriate barriers.

Methods and materials for containment and cleaning up : Take precautionary measures against static discharges. For large liquid spills (> 1 drum), transfer by mechanical means such as vacuum truck to a salvage tank for recovery or safe disposal. Do not flush away residues with water. Retain as contaminated waste. Allow residues to evaporate or soak up with an appropriate absorbent material and dispose of safely. Remove contaminated soil and dispose of safely. For small liquid spills (< 1 drum), transfer by mechanical means to a labeled, sealable container for product recovery or safe disposal. Allow residues to evaporate or soak up with an appropriate absorbent material and dispose of safely. Remove contaminated soil and dispose of safely.

Avoid contact with skin, eyes and clothing.  
Evacuate the area of all non-essential personnel.  
Ventilate contaminated area thoroughly.  
If contamination of site occurs remediation may require specialist advice.  
Take precautionary measures against static discharges.  
Ensure electrical continuity by bonding and grounding (earthing) all equipment.

Observe all relevant local and international regulations.

Additional advice : For guidance on selection of personal protective equipment see Section 8 of this Safety Data Sheet.  
Notify authorities if any exposure to the general public or the environment occurs or is likely to occur.  
For guidance on disposal of spilled material see Section 13 of this Safety Data Sheet.  
Local authorities should be advised if significant spillages cannot be contained.  
Maritime spillages should be dealt with using a Shipboard Oil Pollution Emergency Plan (SOPEP), as required by MARPOL Annex 1 Regulation 26.

---

## 7. HANDLING AND STORAGE

General Precautions : Avoid breathing of or direct contact with material. Only use in well ventilated areas. Wash thoroughly after handling. For guidance on selection of personal protective equipment see Section 8 of this Safety Data Sheet.  
Use the information in this data sheet as input to a risk assessment of local circumstances to help determine appropriate controls for safe handling, storage and disposal of this material.  
Air-dry contaminated clothing in a well-ventilated area before laundering.  
Properly dispose of any contaminated rags or cleaning materials in order to prevent fires.  
Prevent spillages.  
Turn off all battery operated portable electronic devices

# SAFETY DATA SHEET

## AVGAS 100LL

Version 7.1

Revision Date 10.05.2024

Print Date 11.05.2024

(examples include: cellular phones, pagers and CD players) before operating gasoline pump. Contaminated leather articles including shoes cannot be decontaminated and should be destroyed to prevent reuse. For comprehensive advice on handling, product transfer, storage and tank cleaning refer to the product supplier. Do not use as a cleaning solvent or other non-motor fuel uses.

### General Precautions

Maintenance and Fuelling Activities - Avoid inhalation of vapours and contact with skin.

### Advice on safe handling

: Ensure that all local regulations regarding handling and storage facilities are followed.  
When using do not eat or drink.  
Extinguish any naked flames. Do not smoke. Remove ignition sources. Avoid sparks.  
Never siphon by mouth.  
The vapour is heavier than air, spreads along the ground and distant ignition is possible.  
Use local exhaust ventilation if there is risk of inhalation of vapours, mists or aerosols.  
Bulk storage tanks should be diked (bunded).  
Keep container tightly closed and in a cool, well-ventilated place.  
Properly dispose of any contaminated rags or cleaning materials in order to prevent fires.  
Avoid exposure.

The following activities have been associated with high levels of exposure to gasoline vapours: Top-loading of tankers, open ship loading by deck crew, drum filling/emptying and laboratory testing (particularly sample bottle washing). In the interests of air safety, aviation fuels are subject to strict quality requirements and product integrity is of paramount importance. For one source of information on international standards for the quality assurance of aviation fuels, see [www.jjgonline.com](http://www.jjgonline.com).

### Avoidance of contact

: Strong oxidising agents.

### Product Transfer

: Wait 2 minutes after tank filling (for tanks such as those on road tanker vehicles) before opening hatches or manholes. Wait 30 minutes after tank filling ( for large storage tanks) before opening hatches or manholes. During aircraft re-fueling and all other operations extreme care must be taken to avoid any source of ignition from igniting vapour.

Avoid splash filling Keep containers closed when not in use. Do not use compressed air for filling discharge or handling. Contamination resulting from product transfer may give rise to light hydrocarbon vapour in the headspace of tanks that have previously contained gasoline. This vapour may explode if there is a source of ignition. Partly filled containers present a greater hazard than those that are full, therefore handling, transfer and sampling activities need special care.

Even with proper grounding and bonding, this material can still accumulate an electrostatic charge. If sufficient charge is allowed to accumulate, electrostatic discharge and ignition of flammable air-vapour mixtures can occur. Be aware of handling operations that may give rise to additional hazards that result from the accumulation of static charges. These include but are not limited to pumping (especially turbulent flow), mixing, filtering, splash filling, cleaning and filling of tanks and containers, sampling, switch loading, gauging, vacuum truck operations, and mechanical movements. These activities may lead to static discharge e.g. spark formation. Restrict line velocity during pumping in order to avoid generation of electrostatic discharge ( $\leq 1$  m/s until fill pipe submerged to twice its diameter, then  $\leq 7$  m/s). Avoid splash filling. Do NOT use compressed air for filling, discharging, or handling operations.

### Storage

#### Other data

- : Drum and small container storage:
  - Keep containers closed when not in use.
  - Drums should be stacked to a maximum of 3 high.
  - Use properly labeled and closable containers.
  - Packaged product must be kept tightly closed and stored in a diked (bunded) well-ventilated area, away from, ignition sources and other sources of heat.
  - Take suitable precautions when opening sealed containers, as pressure can build up during storage.
- Tank storage:
  - Tanks must be specifically designed for use with this product.
  - Bulk storage tanks should be diked (bunded).
  - Locate tanks away from heat and other sources of ignition.
  - Cleaning, inspection and maintenance of storage tanks is a specialist operation, which requires the implementation of strict procedures and precautions.
  - Electrostatic charges will be generated during pumping.
  - Electrostatic discharge may cause fire. Ensure electrical continuity by bonding and grounding (earthing) all equipment to reduce the risk.
  - The vapours in the head space of the storage vessel may lie in the flammable/explosive range and hence may be flammable.
  - Refer to section 15 for any additional specific legislation covering the packaging and storage of this product.

# SAFETY DATA SHEET

## AVGAS 100LL

Version 7.1

Revision Date 10.05.2024

Print Date 11.05.2024

- Packaging material : Suitable material: For containers, or container linings use mild steel, stainless steel., Aluminium may also be used for applications where it does not present an unnecessary fire hazard., Examples of suitable materials are: high density polyethylene (HDPE), polypropylene (PP), and Viton (FKM), which have been specifically tested for compatibility with this product., For container linings, use amine-adduct cured epoxy paint., For seals and gaskets use: graphite, PTFE, Viton A, Viton B.  
Unsuitable material: Some synthetic materials may be unsuitable for containers or container linings depending on the material specification and intended use. Examples of materials to avoid are: natural rubber (NR), nitrile rubber (NBR), ethylene propylene rubber (EPDM), polymethyl methacrylate (PMMA), polystyrene, polyvinyl chloride (PVC), polyisobutylene., However, some may be suitable for glove materials.
- Container Advice : Do not cut, drill, grind, weld or perform similar operations on or near containers. Containers, even those that have been emptied, can contain explosive vapours. Gasoline containers must not be used for storage of other products.
- Specific use(s) : Not applicable
- See additional references that provide safe handling practices for liquids that are determined to be static accumulators: American Petroleum Institute 2003 (Protection Against Ignitions Arising out of Static, Lightning and Stray Currents) or National Fire Protection Agency 77 (Recommended Practices on Static Electricity).  
IEC/TS 60079-32-1: Electrostatic hazards, guidance

## 8. EXPOSURE CONTROLS AND PERSONAL PROTECTION

### Components with workplace control parameters

Components	CAS-No.	Value type (Form of exposure)	Control parameters / Permissible concentration	Basis
Tetraethyl lead	78-00-2			ZA OEL
	Further information: danger of cutaneous absorption			
n-Hexane	110-54-3	OEL-RL	100 ppm	ZA OEL
	Further information: danger of cutaneous absorption, Occupational Exposure Limits - Restricted Limits For Hazardous Chemical Agents			
Xylene, mixed isomers	1330-20-7	OEL- RL STEL/C	300 ppm	ZA OEL
	Further information: danger of cutaneous absorption, Occupational Exposure Limits - Restricted Limits For Hazardous Chemical Agents			
		OEL-RL	200 ppm	ZA OEL
	Further information: danger of cutaneous absorption,			

## SAFETY DATA SHEET

## AVGAS 100LL

Version 7.1

Revision Date 10.05.2024

Print Date 11.05.2024

Occupational Exposure Limits - Restricted Limits For Hazardous Chemical Agents				
Benzene	71-43-2	TWA	0,25 ppm 0,8 mg/m <sup>3</sup>	Shell Internal Standard (SIS) for 8-12 hour TWA.
Benzene		STEL	2,5 ppm 8 mg/m <sup>3</sup>	Shell Internal Standard (SIS) for 15 min (STEL)
Benzene	71-43-2	STEL	2,5 ppm	ACGIH
Benzene	71-43-2	OEL- ML	1 ppm	ZA OEL
	Further information: Occupational Exposure Limits - Maximum Limits For Hazardous Chemical Agents, danger of cutaneous absorption, denotes carcinogenicity, which is based on GHS categorisation, including category 1A, 1B			
		OEL - ML STEL/C	5 ppm	ZA OEL
	Further information: Occupational Exposure Limits - Maximum Limits For Hazardous Chemical Agents, danger of cutaneous absorption, denotes carcinogenicity, which is based on GHS categorisation, including category 1A, 1B			
Cumene	98-82-8	OEL-RL	100 ppm	ZA OEL
	Further information: danger of cutaneous absorption, Occupational Exposure Limits - Restricted Limits For Hazardous Chemical Agents, denotes carcinogenicity, which is based on GHS categorisation, including category 1A, 1B			
Toluene	108-88-3	OEL-RL	40 ppm	ZA OEL
	Further information: danger of cutaneous absorption, Occupational Exposure Limits - Restricted Limits For Hazardous Chemical Agents			
Cyclohexane	110-82-7	OEL-RL	200 ppm	ZA OEL
	Further information: Occupational Exposure Limits - Restricted Limits For Hazardous Chemical Agents			
Ethylbenzene	100-41-4	OEL-RL	40 ppm	ZA OEL
	Further information: danger of cutaneous absorption, Occupational Exposure Limits - Restricted Limits For Hazardous Chemical Agents, denotes carcinogenicity, which is based on GHS categorisation, including category 1A, 1B			
Trimethylbenzene (all isomers)	25551-13-7	OEL-RL	50 ppm	ZA OEL
	Further information: Occupational Exposure Limits - Restricted Limits For Hazardous Chemical Agents			
Naphthalene	91-20-3	OEL-RL	20 ppm	ZA OEL
	Further information: danger of cutaneous absorption, Occupational Exposure Limits - Restricted Limits For Hazardous Chemical Agents, denotes carcinogenicity, which is based on GHS categorisation, including category 1A, 1B			

**Biological occupational exposure limits**

Component	CAS-No.	Control parameters	Biological specimen	Sampling time	Permissible concentration	Basis
n-Hexane	110-54-3	2,5-Hexanedione	Urine	End of shift at end of	0,4 mg/l	ZA BEI

## SAFETY DATA SHEET

## AVGAS 100LL

Version 7.1

Revision Date 10.05.2024

Print Date 11.05.2024

				workweek		
Xylene, mixed isomers	1330-20-7	Methylhippuric acids	Urine	End of shift	1.5.g/g creatinine	ZA BEI
Benzene	71-43-2	S-phenylmercapturic acid (SPMA)	Urine	End of shift	25.µg/g creatinine	ZA BEI
Remarks: Background. The determinant may be present in biological specimens collected from subjects who have not been occupationally exposed, at a concentration which could affect interpretation of the results. Such background concentrations are incorporated in the BEI value.						
Benzene		t,t-Muconic acid (ttMA)	Urine	End of shift	500.µg/g creatinine	ZA BEI
Remarks: Background. The determinant may be present in biological specimens collected from subjects who have not been occupationally exposed, at a concentration which could affect interpretation of the results. Such background concentrations are incorporated in the BEI value.						
Toluene	108-88-3	Toluene	Blood	Prior to last shift of workweek	0,02 mg/l	ZA BEI
Toluene		Toluene	Urine	End of shift	0,03 mg/l	ZA BEI
Toluene		o-Cresol	Urine	End of shift	0.3.mg/g creatinine	ZA BEI
Remarks: Background. The determinant may be present in biological specimens collected from subjects who have not been occupationally exposed, at a concentration which could affect interpretation of the results. Such background concentrations are incorporated in the BEI value.						
Ethylbenzene	100-41-4	Sum of mandelic acid and phenylglyoxylic acid	Urine	End of shift	0.15.g/g creatinine	ZA BEI
Remarks: Non-specific. The determinant is non-specific, since it is also observed after exposure to other chemicals.						

**Monitoring Methods**

Monitoring of the concentration of substances in the breathing zone of workers or in the general workplace may be required to confirm compliance with an OEL and adequacy of exposure controls. For some substances biological monitoring may also be appropriate.

Validated exposure measurement methods should be applied by a competent person and samples analysed by an accredited laboratory.

Examples of sources of recommended exposure measurement methods are given below or contact the supplier. Further national methods may be available.

National Institute of Occupational Safety and Health (NIOSH), USA: Manual of Analytical Methods  
<http://www.cdc.gov/niosh/>

Occupational Safety and Health Administration (OSHA), USA: Sampling and Analytical Methods  
<http://www.osha.gov/>

Health and Safety Executive (HSE), UK: Methods for the Determination of Hazardous Substances  
<http://www.hse.gov.uk/>

Institut für Arbeitsschutz Deutschen Gesetzlichen Unfallversicherung (IFA), Germany  
<http://www.dguv.de/inhalt/index.jsp>



# SAFETY DATA SHEET

## AVGAS 100LL

Version 7.1

Revision Date 10.05.2024

Print Date 11.05.2024

L'Institut National de Recherche et de Sécurité, (INRS), France <http://www.inrs.fr/accueil>

**Engineering measures** : The level of protection and types of controls necessary will vary depending upon potential exposure conditions. Select controls based on a risk assessment of local circumstances. Appropriate measures include:  
Use sealed systems as far as possible.  
Adequate explosion-proof ventilation to control airborne concentrations below the exposure guidelines/limits.  
Firewater monitors and deluge systems are recommended.  
Local exhaust ventilation is recommended.  
Eye washes and showers for emergency use.

### General Information:

Consider technical advances and process upgrades (including automation) for the elimination of releases. Minimise exposure using measures such as closed systems, dedicated facilities and suitable general/local exhaust ventilation. Drain down systems and clear transfer lines prior to breaking containment. Clean/flush equipment, where possible, prior to maintenance. Where there is potential for exposure: restrict access to authorised persons; provide specific activity training to operators to minimise exposures; wear suitable gloves and coveralls to prevent skin contamination; wear respiratory protection when there is potential for inhalation; clear up spills immediately and dispose of wastes safely. Ensure safe systems of work or equivalent arrangements are in place to manage risks. Regularly inspect, test and maintain all control measures. Consider the need for risk based health surveillance.  
Do not ingest. If swallowed, then seek immediate medical assistance.

### Personal protective equipment

#### Protective measures

Personal protective equipment (PPE) should meet recommended national standards. Check with PPE suppliers.

**Respiratory protection** : No respiratory protection is ordinarily required under normal conditions of use.  
In accordance with good industrial hygiene practices, precautions should be taken to avoid breathing of material. If engineering controls do not maintain airborne concentrations to a level which is adequate to protect worker health, select respiratory protection equipment suitable for the specific conditions of use and meeting relevant legislation. Check with respiratory protective equipment suppliers. Where air-filtering respirators are suitable, select an appropriate combination of mask and filter. Select a filter suitable for the combination of organic gases and vapours and particles [Type A/Type P boiling point >65°C (149°F)].

# SAFETY DATA SHEET

## AVGAS 100LL

Version 7.1

Revision Date 10.05.2024

Print Date 11.05.2024

- Hand protection  
Remarks : Personal hygiene is a key element of effective hand care. Gloves must only be worn on clean hands. After using gloves, hands should be washed and dried thoroughly. Application of a non-perfumed moisturizer is recommended. Suitability and durability of a glove is dependent on usage, e.g. frequency and duration of contact, chemical resistance of glove material, dexterity. Always seek advice from glove suppliers. Contaminated gloves should be replaced. For continuous contact we recommend gloves with breakthrough time of more than 240 minutes with preference for > 480 minutes where suitable gloves can be identified. For short-term/splash protection we recommend the same but recognize that suitable gloves offering this level of protection may not be available and in this case a lower breakthrough time maybe acceptable so long as appropriate maintenance and replacement regimes are followed. Glove thickness is not a good predictor of glove resistance to a chemical as it is dependent on the exact composition of the glove material.
- Select gloves tested to a relevant standard (e.g. Europe EN374, US F739). When prolonged or frequent repeated contact occurs, Nitrile gloves may be suitable. (Breakthrough time of > 240 minutes.) For incidental contact/splash protection Neoprene, PVC gloves may be suitable.
- Eye protection : If material is handled such that it could be splashed into eyes, protective eyewear is recommended.
- Skin and body protection : Wear chemical resistant gloves/gauntlets and boots. Where risk of splashing, also wear an apron. Wear antistatic and flame-retardant clothing.

### Environmental exposure controls

- General advice : Local guidelines on emission limits for volatile substances must be observed for the discharge of exhaust air containing vapour. Information on accidental release measures are to be found in section 6.

---

## 9. PHYSICAL AND CHEMICAL PROPERTIES

- Appearance : liquid
- Colour : blue
- Odour : Data not available
- Odour Threshold : Data not available
- pH : Data not available
- Melting point/freezing point : Data not available
- Initial boiling point and boiling range : 25 - 170 °C / 77 - 338 °F

# SAFETY DATA SHEET

## AVGAS 100LL

Version 7.1

Revision Date 10.05.2024

Print Date 11.05.2024

Flash point	: <= -40 °C / -40 °F
Evaporation rate	: Data not available
Flammability (solid, gas)	: Not applicable
Upper explosion limit	: Data not available
Lower explosion limit	: 1 %(V)
Vapour pressure	: 60 - 90 kPa (50,0 °C / 122,0 °F) Method: Unspecified
	38 - 49 kPa (38,0 °C / 100,4 °F) Method: Unspecified
Relative vapour density	: Data not available
Relative density	: Data not available
Density	: 700,0 - 730,0 kg/m <sup>3</sup> (15,0 °C / 59,0 °F)
Solubility(ies)	
Water solubility	: negligible
Solubility in other solvents	: Data not available
Partition coefficient: n-octanol/water	: log Pow: 2 - 7
Auto-ignition temperature	: > 250 °C / 482 °F
Decomposition temperature	: Data not available
Viscosity	
Viscosity, dynamic	: Data not available
Viscosity, kinematic	: Typical 0,75 mm <sup>2</sup> /s (40,0 °C / 104,0 °F)
	0,25 - 0,75 mm <sup>2</sup> /s (40,0 °C / 104,0 °F) Method: Unspecified
Explosive properties	: Classification Code: Not classified.
Oxidizing properties	: Not applicable
Conductivity	: Low conductivity: < 100 pS/m, The conductivity of this material makes it a static accumulator., A liquid is typically considered nonconductive if its conductivity is below 100 pS/m and is considered semi-conductive if its conductivity is below 10,000 pS/m., Whether a liquid is nonconductive or semiconductive,

# SAFETY DATA SHEET

## AVGAS 100LL

Version 7.1

Revision Date 10.05.2024

Print Date 11.05.2024

the precautions are the same., A number of factors, for example liquid temperature, presence of contaminants, and anti-static additives can greatly influence the conductivity of a liquid

Particle size : Data not available

Data not available

---

### 10. STABILITY AND REACTIVITY

Reactivity : May oxidise in the presence of air.

Chemical stability : Stable under normal conditions of use.

Possibility of hazardous reactions : No hazardous reaction is expected when handled and stored according to provisions

Conditions to avoid : Avoid heat, sparks, open flames and other ignition sources.

In certain circumstances product can ignite due to static electricity.

Incompatible materials : Strong oxidising agents.

Hazardous decomposition products : Hazardous decomposition products are not expected to form during normal storage.  
Thermal decomposition is highly dependent on conditions. A complex mixture of airborne solids, liquids and gases including carbon monoxide, carbon dioxide, sulphur oxides and unidentified organic compounds will be evolved when this material undergoes combustion or thermal or oxidative degradation.

---

### 11. TOXICOLOGICAL INFORMATION

Basis for assessment : Information given is based on product data, a knowledge of the components and the toxicology of similar products. Unless indicated otherwise, the data presented is representative of the product as a whole, rather than for individual component(s).

#### Acute toxicity

**Product:**

Acute oral toxicity : LD50 Oral Rat: > 2.000 mg/kg  
Remarks: Low toxicity  
Based on available data, the classification criteria are not met.

# SAFETY DATA SHEET

## AVGAS 100LL

Version 7.1

Revision Date 10.05.2024

Print Date 11.05.2024

Acute inhalation toxicity : LC 50 Rat: > 20 mg/l  
Exposure time: 4 h  
Remarks: Low toxicity

Remarks: Based on available data, the classification criteria are not met.

Acute dermal toxicity : LD 50 Rabbit: > 2.000 mg/kg  
Remarks: Low toxicity  
Based on available data, the classification criteria are not met.

Acute toxicity (other routes of administration) :  
Remarks: Exposure may occur via inhalation, ingestion, skin absorption, skin or eye contact, and accidental ingestion.

### Skin corrosion/irritation

**Product:**

Remarks: Irritating to skin.

### Serious eye damage/eye irritation

**Product:**

Remarks: Not irritating to eye., Based on available data, the classification criteria are not met.

### Respiratory or skin sensitisation

**Product:**

Remarks: Not a sensitiser.  
Based on available data, the classification criteria are not met.

### Germ cell mutagenicity

**Product:**

Remarks: Non mutagenic, Based on available data, the classification criteria are not met.

### Carcinogenicity

**Product:**

Remarks: Based on available data, the classification criteria are not met.

Material	GHS/CLP Carcinogenicity Classification
n-Hexane	No carcinogenicity classification.
Tetraethyl lead	No carcinogenicity classification.
Gasoline	No carcinogenicity classification.
Xylene, mixed isomers	No carcinogenicity classification.
Benzene	Carcinogenicity Category 1A

# SAFETY DATA SHEET

## AVGAS 100LL

Version 7.1

Revision Date 10.05.2024

Print Date 11.05.2024

Cumene	Carcinogenicity Category 1B
Toluene	No carcinogenicity classification.
Cyclohexane	No carcinogenicity classification.
Ethylbenzene	No carcinogenicity classification.
Trimethylbenzene (all isomers)	No carcinogenicity classification.
Naphthalene	Carcinogenicity Category 2

Material	Other Carcinogenicity Classification
Tetraethyl lead	IARC: Group 3: Not classifiable as to its carcinogenicity to humans
Gasoline	IARC: Group 2B: Possibly carcinogenic to humans
Xylene, mixed isomers	IARC: Group 3: Not classifiable as to its carcinogenicity to humans
Benzene	IARC: Group 1: Carcinogenic to humans
Cumene	IARC: Group 2B: Possibly carcinogenic to humans
Toluene	IARC: Group 3: Not classifiable as to its carcinogenicity to humans
Ethylbenzene	IARC: Group 2B: Possibly carcinogenic to humans
Naphthalene	IARC: Group 2B: Possibly carcinogenic to humans

### Reproductive toxicity

#### Product:

Remarks: Does not impair fertility.

Remarks: Contains n-Hexane, CAS # 110-54-3.

Remarks: Contains Toluene, CAS # 108-88-3., Many case studies involving abuse during pregnancy indicate that toluene can cause birth defects, growth retardation and learning difficulties.

### STOT - single exposure

#### Product:

Remarks: High concentrations may cause central nervous system depression resulting in headaches, dizziness and nausea.

### STOT - repeated exposure

#### Product:

Remarks: May cause damage to organs or organ systems through prolonged or repeated

# SAFETY DATA SHEET

## AVGAS 100LL

Version 7.1

Revision Date 10.05.2024

Print Date 11.05.2024

exposure.

Exposure routes: Inhalation  
Target Organs: Liver, Kidney, Brain

### Aspiration toxicity

#### Product:

Aspiration into the lungs when swallowed or vomited may cause chemical pneumonitis which can be fatal.

### Further information

#### Product:

Remarks: Exposure to very high concentrations of similar materials has been associated with irregular heart rhythms and cardiac arrest.

Remarks: Classifications by other authorities under varying regulatory frameworks may exist.

---

## 12. ECOLOGICAL INFORMATION

### Ecotoxicity

#### Product:

Toxicity to fish (Acute toxicity)	:	Remarks: LL/EL/IL50 > 1 <= 10 mg/l Toxic
Toxicity to crustacean (Acute toxicity)	:	Remarks: LL/EL/IL50 > 1 <= 10 mg/l Toxic
Toxicity to algae/aquatic plants (Acute toxicity)	:	Remarks: LL/EL/IL50 > 1 <= 10 mg/l Toxic
Toxicity to fish (Chronic toxicity)	:	Remarks: NOEC/NOEL > 1.0 - <= 10 mg/l
Toxicity to crustacean (Chronic toxicity)	:	Remarks: NOEC/NOEL > 1.0 - <= 10 mg/l
Toxicity to microorganisms (Acute toxicity)	:	Remarks: LL/EL/IL50 >10 <= 100 mg/l Harmful

#### Components:

##### Tetraethyl lead :

M-Factor (Short-term (acute) aquatic hazard) : 1

### Persistence and degradability

# SAFETY DATA SHEET

## AVGAS 100LL

Version 7.1

Revision Date 10.05.2024

Print Date 11.05.2024

### Product:

Biodegradability : Remarks: Oxidises rapidly by photo-chemical reactions in air., Readily biodegradable., Not Persistent per IMO criteria., International Oil Pollution Compensation (IOPC) Fund definition: "A non-persistent oil is oil, which, at the time of shipment, consists of hydrocarbon fractions, (a) at least 50% of which, by volume, distills at a temperature of 340°C (645°F) and (b) at least 95% of which, by volume, distills at a temperature of 370°C (700°F) when tested by the ASTM Method D-86/78 or any subsequent revision thereof."

### Bioaccumulative potential

#### Product:

Bioaccumulation : Remarks: Contains constituents with the potential to bioaccumulate.

Partition coefficient: n-octanol/water : log Pow: 2 - 7

### Mobility in soil

#### Product:

Mobility : Remarks: If the product enters soil, one or more constituents will or may be mobile and may contaminate groundwater., Floats on water.

### Other adverse effects

no data available

#### Product:

Additional ecological information : Films formed on water may affect oxygen transfer and damage organisms.

---

## 13. DISPOSAL CONSIDERATIONS

### Disposal methods

Waste from residues : Recover or recycle if possible.  
It is the responsibility of the waste generator to determine the toxicity and physical properties of the material generated to determine the proper waste classification and disposal methods in compliance with applicable regulations. Waste arising from a spillage or tank cleaning should be disposed of in accordance with prevailing regulations, preferably to a recognised collector or contractor. The competence of the collector or contractor should be established beforehand.  
Do not dispose into the environment, in drains or in water courses.  
Do not dispose of tank water bottoms by allowing them to drain into the ground.  
MARPOL - see International Convention for the Prevention of Pollution from Ships (MARPOL 73/78) which provides technical aspects at controlling pollutions from ships.



# SAFETY DATA SHEET

## AVGAS 100LL

Version 7.1

Revision Date 10.05.2024

Print Date 11.05.2024

Contaminated packaging : Drain container thoroughly.  
After draining, vent in a safe place away from sparks and fire.  
Residues may cause an explosion hazard.  
Do not puncture, cut, or weld uncleaned drums.  
Send to drum recoverer or metal reclaimer.  
Do not pollute the soil, water or environment with the waste container.

Local legislation  
Remarks : Disposal should be in accordance with applicable regional,  
national, and local laws and regulations.  
Local regulations may be more stringent than regional or  
national requirements and must be complied with.

---

### 14. TRANSPORT INFORMATION

#### International Regulations

##### ADR

UN number : 1203  
Proper shipping name : GASOLINE  
Class : 3  
Packing group : II  
Labels : 3  
Hazard Identification Number : 33  
Environmentally hazardous : yes

##### IATA-DGR

UN/ID No. : UN 1203  
Proper shipping name : GASOLINE  
Class : 3  
Packing group : II  
Labels : 3

##### IMDG-Code

UN number : UN 1203  
Proper shipping name : GASOLINE  
Class : 3  
Packing group : II  
Labels : 3  
Marine pollutant : yes

#### Maritime transport in bulk according to IMO instruments

MARPOL Annex 1 rules apply for bulk shipments by sea.

#### Special precautions for user

Remarks : Special Precautions: Refer to Section 7, Handling & Storage,  
for special precautions which a user needs to be aware of or  
needs to comply with in connection with transport.

---

**15. REGULATORY INFORMATION****Safety, health and environmental regulations/legislation specific for the substance or mixture**

The regulatory information is not intended to be comprehensive. Other regulations may apply to this material.

---

**16. OTHER INFORMATION****Full text of H-Statements**

H224	Extremely flammable liquid and vapour.
H300	Fatal if swallowed.
H304	May be fatal if swallowed and enters airways.
H310	Fatal in contact with skin.
H315	Causes skin irritation.
H330	Fatal if inhaled.
H336	May cause drowsiness or dizziness.
H350	May cause cancer.
H360Df	May damage the unborn child. Suspected of damaging fertility.
H361d	Suspected of damaging the unborn child.
H373	May cause damage to organs through prolonged or repeated exposure.
H400	Very toxic to aquatic life.
H410	Very toxic to aquatic life with long lasting effects.
H411	Toxic to aquatic life with long lasting effects.

**Full text of other abbreviations**

Acute Tox.	Acute toxicity
Aquatic Acute	Short-term (acute) aquatic hazard
Aquatic Chronic	Long-term (chronic) aquatic hazard
Asp. Tox.	Aspiration hazard
Carc.	Carcinogenicity
Flam. Liq.	Flammable liquids
Repr.	Reproductive toxicity
Skin Irrit.	Skin irritation
STOT RE	Specific target organ toxicity - repeated exposure
STOT SE	Specific target organ toxicity - single exposure

Abbreviations and Acronyms : The standard abbreviations and acronyms used in this document can be looked up in reference literature (e.g. scientific dictionaries) and/or websites.

SDS Regulation : Regulation 1907/2006/EC

**Further information**

Other information : A vertical bar (|) in the left margin indicates an amendment

# SAFETY DATA SHEET

## AVGAS 100LL

Version 7.1

Revision Date 10.05.2024

Print Date 11.05.2024

---

from the previous version.

This information is based on our current knowledge and is intended to describe the product for the purposes of health, safety and environmental requirements only. It should not therefore be construed as guaranteeing any specific property of the product.